



SSA.. without auxiliary switch



SSA..1 with auxiliary switch

ACVATIX™

Electromotoric actuators

For radiator valves, MiniCombiValves (MCV) and small valves

SSA31..
SSA81..
SSA61..

- **SSA31..** operating voltage AC 230 V 3-position control signal
- **SSA81..** operating voltage AC 24 V 3-position control signal
- **SSA61..** operating voltage AC / DC 24 V DC 0...10 V control signal
- **SSA61EP..** equal-percentage valve characteristic
- **Nominal force 100 N**
- **Automatic identification of valve stroke**
- **Direct mounting with coupling nut, no tools required**
- **Basic types complete with plug-in connecting cable, length 1.5 m**
- **Optional cable types**
 - Cable length 2.5 m and 4.5 m
 - Halogen-free cables
- **Manual override and position indication**
- **Parallel connection of multiple actuators possible**
- **Auxiliary switch integrated in SSA31.1 and SSA81.1 actuators**
- **Optional tamper-proof fitting to prevent dismantling**

Use

- For Combi valves VPP46.., VPI46.. and MiniCombiValves, VPD.., VPE..
- For small valves, VD1..CLC
- For radiator valves with M30 x 1.5 threaded fitting, nominal closing dimension 11.6 mm and a 2.5 mm nominal stroke (without adapter). Also for use with third-party valves in conjunction with AV-type adapter

- For modulating or 3-position control in heating systems, chilled ceilings and terminal units.

Type summary

Type reference	Operating voltage	Run time at 50 Hz	Control signal	Connecting cable	Auxiliary switch
SSA31	AC 230 V	150 s	3-position	1.5 m	
SSA31/00 ¹⁾				no cable	
SSA31.1				1.5 m	Yes
SSA81	AC 24 V			1.5 m	
SSA81/00 ¹⁾				no cable	
SSA81.1				1.5 m	Yes
SSA61	AC / DC 24 V	34 s	DC 0...10 V	1.5 m	
SSA61/00 ¹⁾				no cable	
SSA61EP ²⁾				1.5 m	
SSA61EP/00 ²⁾				no cable	

¹⁾ For available cable lengths or terminal block connectors refer to "Accessories", page 4

²⁾ With equal-percentage valve characteristic

Accessories

Type reference	Description	Operating voltage	Control signal
ASY3L25	Connecting cable 2.5 m	AC 230 V	3-position
ASY3L45	Connecting cable 4.5 m		
ASY8L25	Connecting cable 2.5 m	AC 24 V	
ASY8L45	Connecting cable 4.5 m		
ASY8L45HF	Connecting cable 4.5 m, halogen-free, VDE 0207-24		
ASY6L25	Connecting cable 2.5 m	AC / DC 24 V	
ASY6L45	Connecting cable 4.5 m		
ASY6L45HF	Connecting cable 4.5 m, halogen-free, VDE 0207-24		
ASY98	Retaining screw for terminal block connectors. Included in ASY99 and ASY100.		
ASY99	Terminal block connector for 3-position actuators SSA81../00		
ASY100	Terminal block connector for DC 0...10 V modulating actuators SSA61/00		
AL40	Tamper-proof fitting to prevent dismantling of actuators		
Adapter type	for third-party valves	Adapter type	for third-party valves
AV51	Beulco old (M30x1.0)	AV57	Herz
AV53	Danfoss RA-N (RA2000)	AV58	Oventrop old (M30x1.0), till 2002
AV54	Danfoss RAVL	AV59 ²⁾	Vaillant
AV55	Danfoss RAV	AV60	TA, till 2002 ¹⁾
AV56	Giacomini	AV61	Markaryd (MMA)

¹⁾ No adapter required for type TBV-C

²⁾ While stocks last

Ordering

Example:

Type	Stock no.	Description	Quantity
SSA81/00	SSA81/00	Electromotoric actuator	2
ASY8L45	ASY8L45	Connecting cable	2

Delivery

Actuators, valves and accessories are packed separately. Items are supplied individually packed.

Rev.-No.

Overview tables, see page 9.

Equipment combinations

Type reference	Valve type	k_{vs} [m ³ /h]	\dot{V} [l/h]	PN class	Data sheet
VPD.., VPE..	MCV radiator valves		25...483	PN 10	N2185
VD1..CLC	Small valves	0.25...2.60			N2103
VPP46.., VPI46..	Combi valves		30...4001	PN 25	N4855

For other radiator valves with type AV.. adapters refer to "Type summary / accessories"

Radiator valves (M30 x 1.5) from other manufacturers, without adapter:

- Heimeier
- Crane D981..
- TA-Type TBV-C
- Oventrop M30 x 1.5 (from 2001)
- MNG
- Junkers
- Honeywell-Braukmann
- Cazzaniga
- Beulco (new)

k_{vs} = nominal flow rate of cold water (5...30 °C) through the fully open valve (H_{100}) at a differential pressure of 100 kPa (1 bar)

\dot{V} = Nominal volume flow at 0.5 mm stroke

Valves from other manufacturers

To ensure trouble-free operation of third-party valves with the SSA.. actuator, the valves must satisfy the following requirements:

- Threaded connections with coupling nut M30 x 1.5
- Nominal force $F \leq 100$ N
- Dimension x $x > 9.0$ mm
- Dimension y $y \leq 14.5$ mm

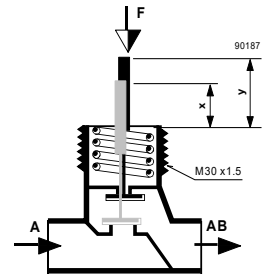

Function / mechanical design

When the actuator is driven by DC 0...10 V control voltage or by a 3-position signal, it produces a stroke which is transmitted to the valve stem.

The description of operation in this document applies to the valve versions which are fully open when de-energized (NO).

3-position control signal

SSA31.. / SSA81..

- Voltage at Y1: Stem retracts Valve opens
- Voltage at Y2: Stem extends Valve closes
- No voltage at Y1 and Y2: Actuator maintains its current position

DC 0...10 V control signal

SSA61, SSA61/00

- The valve opens / closes in proportion to the control signal at Y.
- At DC 0 V, the valve is fully closed (A → AB).
- When power supply is removed, the actuator maintains its current position.

¹⁾ Actuator is calibrated to 2.5 mm stroke of VPI46.15.L06

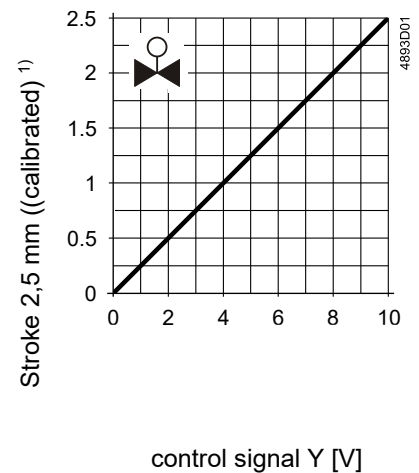

DC 0...10 V control signal
SSA61EP,
SSA61EP/00

Combi valves VPI46../VPP46.. in combination with SSA61EP.. have an equal-percentage characteristics.

- The valve opens / closes in equal percentage ratio to the control signal at Y.
- At DC 0 V, the valve is fully closed (A → AB).
- When power supply is removed, the actuator maintains its current position.

1) Actuator is calibrated to 2.5 mm stroke of VPI46.15L06

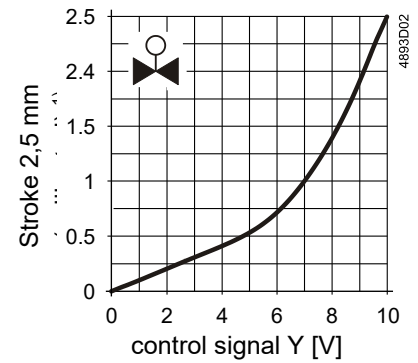

Features and advantages

- Plastic housing
- Locking-proof, maintenance-free gear train
- Manual override with hexagonal socket wrench 3 mm
- Reduced power consumption in the holding positions
- Load-dependent switch-off in the event of overload and in stroke end positions
- Parallel operation of 6 SSA31..., 24 SSA81.. and 10 SSA61.. possible, provided the controllers' output is sufficient
- Terminal block connectors for customer made cables available (only for use with AC 24 V and AC / DC 24 V actuators)
- Connecting cables with AC 24 V and AC 230 V connectors cannot be mixed up
- Halogen-free cables available

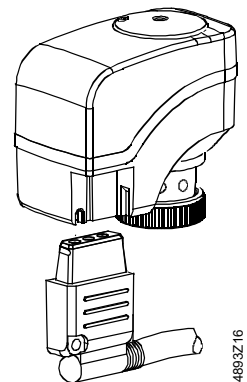

Accessories

Adapter type AV.. for third-party valves

Adapter types AV51 to AV61 are available for mounting the SSA.. actuators on third-party radiator valves as shown under "Type summary/accessories", page 2.

Tamper-proof fitting AL40

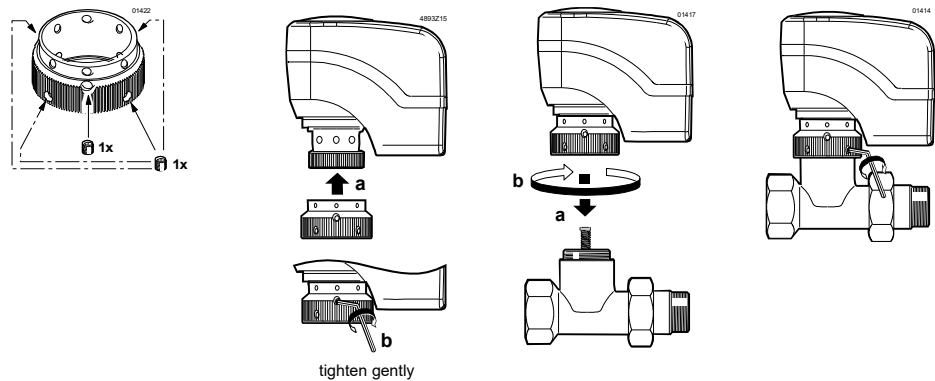

Retaining screw ASY98

Type ASY98 to secure the cable connector. Included in ASY99 and ASY100.

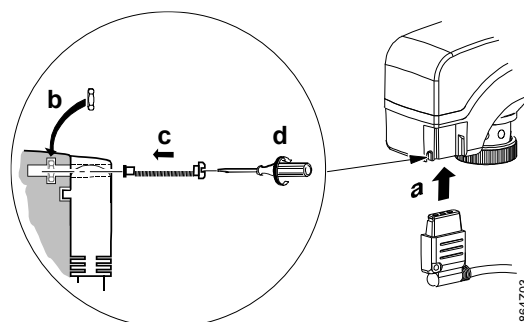

The cable connector snaps into position, but can be additionally secured with the retaining screw.

Terminal block connectors
ASY99
ASY100

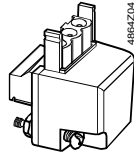

For special cable lengths of the AC / DC 24 V actuators.

- Type ASY99 for 3-position actuators SSA81../00
- Type ASY100 for DC 0...10 V modulating actuators SSA61/00

The terminal block connectors are supplied complete with mounting instructions (74 319 0385 0).

Notes

Engineering

The actuators must be electrically connected in accordance with local regulations (refer to "Connection diagrams", page 9).



Regulations and requirements to ensure the safety of people and property must be observed at all times!

The permissible temperatures (refer to "Technical data", page 7) must be observed. The connecting cable of the actuator may come into contact with the hot valve body, provided the temperature of the valve body does not exceed 80 °C. Actuator types SSA 31.1 and SSA81.1 have a built-in auxiliary switch. The switch cannot be fitted in other actuators later.

Mounting

Mounting instructions (Ref. 74 319 0497 0) are enclosed in the product packaging. The actuator and valve are assembled with the coupling nut; no tools or adjustments are required.

The actuator must be fitted in position 1 with the power disconnected (refer also to "Manual override", page 6):



- Position the actuator and tighten the coupling nut manually
- Do not use any tools such as wrenches
- Avoid lateral pressure or (cable) tension on the mounted actuator!

In the case of actuators without a connecting cable (SSA../00), the separately ordered terminal block connector and connecting cable must be fitted.

Orientation

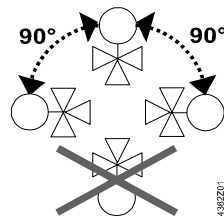

Installation

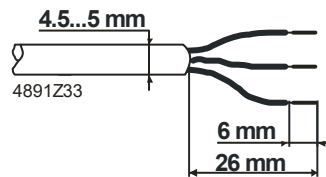

Crimp ferrule on stripped wire of connecting cable.

Commissioning

When commissioning, check the wiring and the functioning of the actuator and auxiliary switch, if fitted.

- Actuator stem extends (from position 1 to 0): Valve closes
- Actuator stem retracts (from position 0 to 1): Valve opens

Self-calibration



During commissioning and whenever the operating voltage is switched on, the SSA61.. runs a self-calibration routine. (Valve stroke 0 → Max. stroke → Setpoint). Never intervene manually in this process.

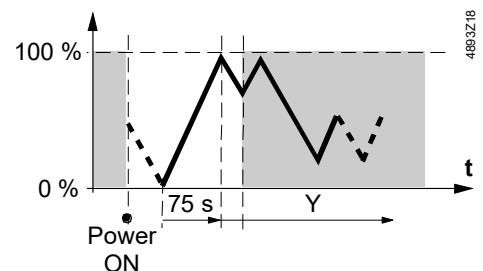

Note: Correct calibration is only possible

- with valve
- stroke > 1.5 mm

The second or third attempt at calibration occurs automatically after an 8-minute delay.

After three failed calibration attempts the actuator stem remains in the extended position and the radiator valves are closed.

For valves with strokes < 1.5 mm, the actuator/valve combination locks after three failed calibration attempts.

Operation

A 3 mm hexagonal socket wrench can be used to move the actuator to any position. However, if a control signal from the controller is present, then this takes priority in determining the position.

Note To retain the manually set position, unplug the connecting cable or switch off the operating voltage and the control signal.

Manual override

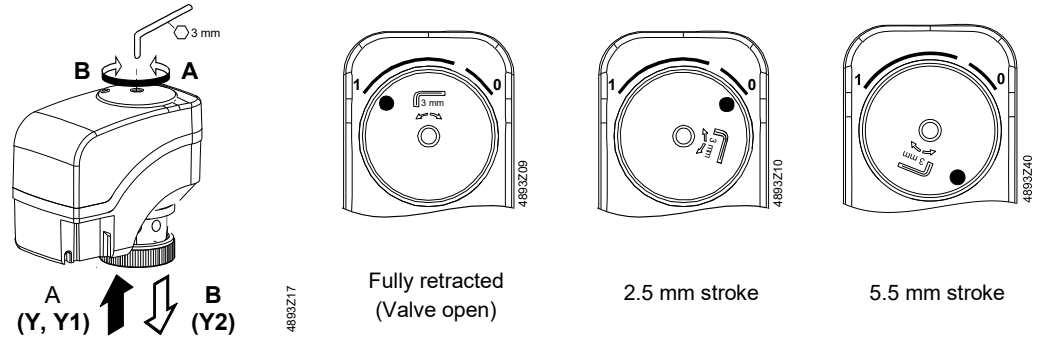

Maintenance

The actuators are maintenance-free.

When carrying out service work on the plant, following must be noted:

- Turn power off (e.g. remove the plug)
 - If necessary, disconnect electrical connections from the terminals
 - The actuator must be commissioned only with a correctly mounted valve in place!
- SSA.. actuators cannot be repaired; the complete unit must be replaced.



Repair

Disposal

	<p>The device is considered an electronics device for disposal in terms of European Directive 2012/19/EU and may not be disposed of as domestic garbage.</p> <ul style="list-style-type: none"> ● Dispose of the device through channels provided for this purpose. ● Comply with all local and currently applicable laws and regulations.
--	--

Warranty

The technical data given for these applications is valid only when the actuators are used with the Siemens valves listed under "Equipment combinations", page 2.

The use of the SSA.. actuators in conjunction with third-party valves invalidates any warranty offered by Siemens Building Technologies / HVAC Products.

Technical data

		SSA31..	SSA81..	SSA61../SSA61EP..
Power supply	Operating voltage	AC 230 V	AC 24 V	AC 24 V or DC 24 V
	Voltage tolerance	± 15%	± 20%	± 20% ± 25%
	Frequency	50 / 60 Hz		
	Max. power consumption	6 VA	0.8 VA	2.5 VA
	△ Fuse for incoming cable	2 A, quickblow		
Control	Control signal	3-position		DC 0...10 V
	Input impedance for DC 0...10 V			> 100 kOhm
	Parallel operation (number of actuators) ¹⁾	max. 6	max. 24	max. 10
Functional data	Run time for 2.5 mm stroke at 50 Hz	150 s		34 s
	Positioning speed	60 s/mm		13.6 s/mm
	Nominal stroke	2.5 mm (max. 5.5 mm)		
	Nominal force	100 N		
	Perm. temperature of medium in the connected valve	1...110 °C (1...90 °C for MCV-radiator valves)		
Electrical connections	Connecting cable of basic types	1.5 m 3-core to EN 60320 / IEC 60227		
	ASY 99, ASY100 cable diameter		< 5 mm	
	wire cross section		0,5...0,75 mm ²	
	ASY3L.. wire cross section	0,75 mm ²		
Norms and directives	ASY6L.., ASY8L.. wire cross section		0,5 mm ²	
	Electromagnetic compatibility (Application)	For residential, commercial and light- industrial environments		
	Product standard	EN60730-x		
	EU Conformity (CE)	A5W90000891 ²⁾	A5W90000893 ²⁾	A5W90000892 ²⁾
	RCM Conformity	A5W90000906_A ²⁾	A5W90000908_A ²⁾	A5W90000907_A ²⁾
	EAC Conformity	Eurasia Conformity		
	Protection class to EN 60730	II	III	
	Contamination level	EN 60730, Class 2		
	Housing protection Upright to horizontal	IP40 to EN 60529		
	Environmental compatibility	The product environmental declaration CE1E4893en01 ²⁾ contains data on environmentally compatible product design and assessments (RoHS compliance, materials composition, packaging, environmental benefit, disposal).		
	Dimensions / weight	Dimensions	refer to "Dimensions", page 10	
Coupling thread to valve		Coupling nut M30 x 1.5		
Weight with / without auxiliary switch		0.4 kg / 0.35 kg		
Housing colors	Base	RAL 7035 light gray		
	Cover	RAL 9003 signal white		
Auxiliary switch	Mounted in SSA31.1 and SSA81.1	1 change-over switch		
	Switching point adjustable	0...100%		
	Factory setting 50 %			
	Switching capacity ³⁾	max. AC 250 V, 1 A (0.5 A)		
	Connecting cable (recommended)	H03VV-F, 2x0.5...0.75 mm ²		

¹⁾ Provided the controller output is sufficient

²⁾ The documents can be downloaded from <http://siemens.com/bt/download>

General ambient conditions

General ambient conditions	Operation	Transport	Storage
	EN 60721-3-3	EN 60721-3-2	EN 60721-3-1
Environmental conditions	Class 3K3	Class 2K3	Class 1K3
Temperature	+1...+50 °C	-25...+70 °C	-5...+50 °C
Humidity	5...85 % r.h.	< 95 % r.h.	5...95 % r.h.

Connecting cable

ASY3L.. with SSA31..

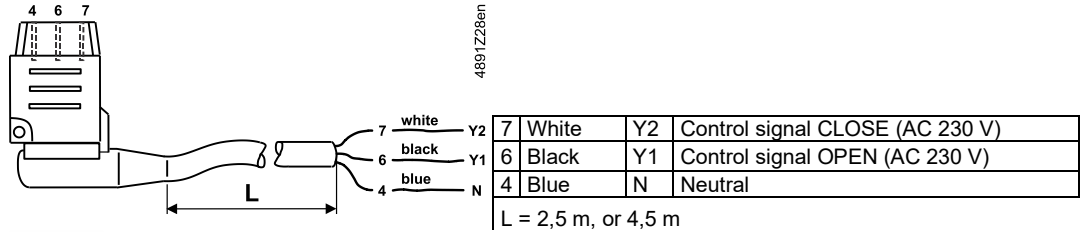

ASY8L.. with SSA81..

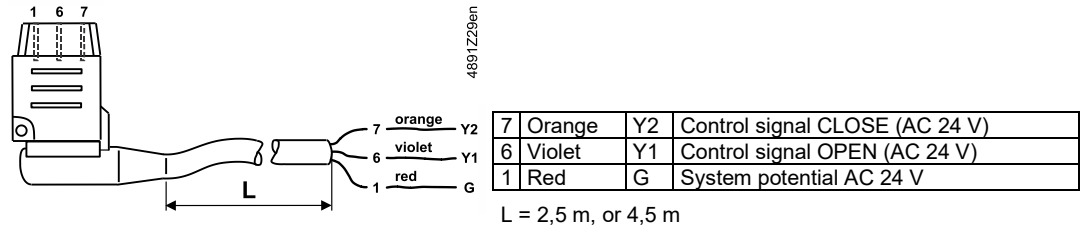

ASY6L.. with SSA61..

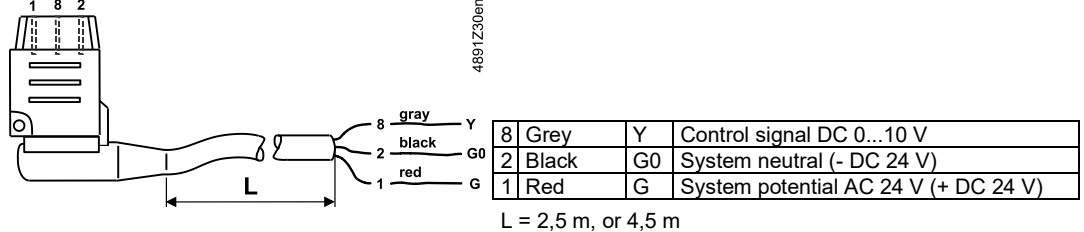

Connection terminals

ASY99
for SSA81..

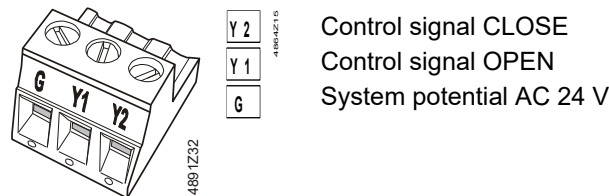

ASY100
for SSA61..

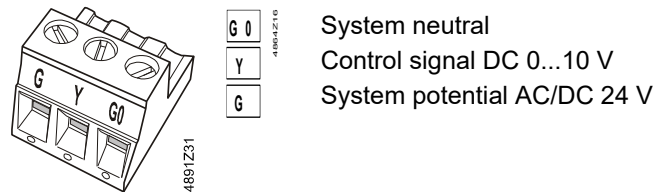

Terminals for auxiliary switches

SSA31.1, SSA81.1

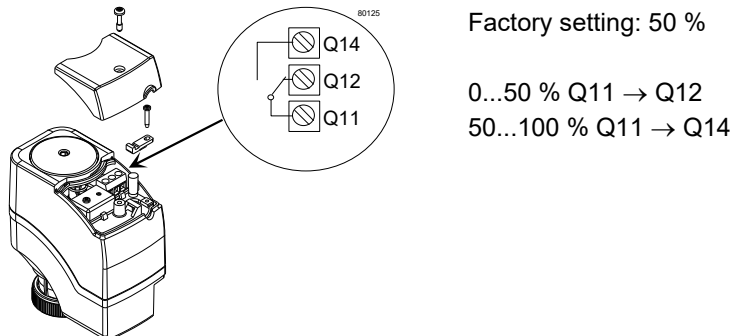

The switching point can be adjusted by turning the switching cam with a screwdriver (see Mounting Instructions).

Recommended connecting cable: H03VV-F, 2x0.5...0.75 mm².

Connection diagrams

SSA31..

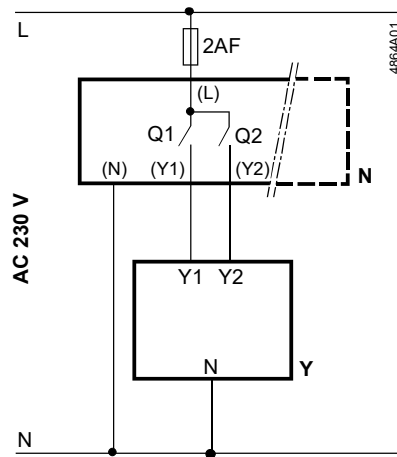

N Controller
 Y Actuator
 L System potential AC 230 V
 N System neutral
 Y1, Y2 Control signal OPEN, CLOSE
 Q1, Q2 Controller contacts

SSA81..

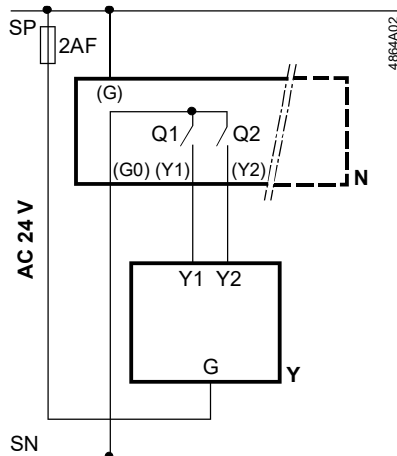

N Controller
 Y Actuator
 SP, G System potential AC 24 V
 SN, G0 System neutral
 Y1, Y2 Control signal OPEN, CLOSE
 Q1, Q2 Controller contacts

SSA61..

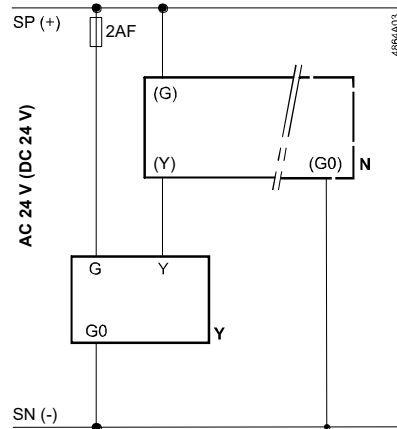

N Controller
 Y Actuator
 SP, G System potential AC 24 V
 SN, G0 System neutral
 Y Control signal

Dimensions

Dimensions in mm

Actuator without auxiliary switch

SSA31..

SSA81..

SSA61..

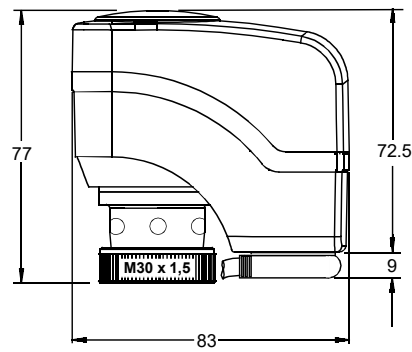

Actuator with auxiliary switch

SSA31.1..

SSA81.1..

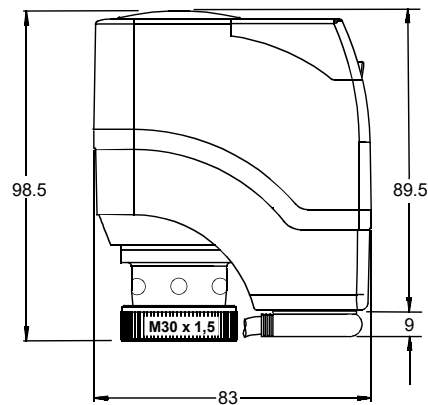

Revision numbers

Type reference	Valid from Rev.-No.	Type reference	Valid from Rev.-No.
SSA31	K	SSA61	K
SSA31/00	K	SSA61/00	K
SSA31.1	K		
SSA81	K		
SSA81/00	K		
SSA81.1	K		

Issued by
 Siemens Switzerland Ltd
 Building Technologies Division
 International Headquarters
 Theilerstrasse 1a
 6301 Zug
 Switzerland
 Tel. +41 41-724 24 24
www.siemens.com/buildingtechnologies

© Siemens Switzerland Ltd, 2005
 Technical specifications and availability subject to change without notice.