

POWERS™ Controls

Analog Receiver Gauges

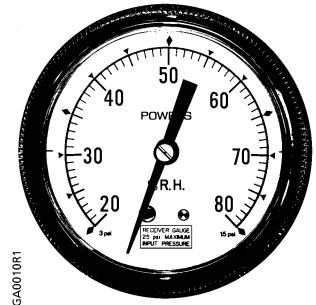

Description Analog receiver gauges are round dial instruments that indicate the output signal from a pneumatic transmitter. The gauges are available in three sizes. The 1-1/2-inch gauge is pipe mounted only. The 2-1/2 and 3-1/2-inch gauges are flush mounted, usually in the central control panel.

- Features**
- Snap-in ring for 1-1/2-inch gauge, 1/4 turn on 2-1/2 and 3-1/2-inch gauges.
 - Linkage consists of bourdon tube, geared linkage, return spring and pointer.
 - Points on the gauge dial indicate corresponding psi (kPa) measurements.

Product Numbers	Description	Table No.
	Analog Receiver Gauges – English Units	Table 1
	Analog Receiver Gauges – Metric Units	Table 2
	Analog Receiver Gauges – Dual Scale	Table 3

Specifications		
Standard operating pressure		3 to 15 psi (21 to 103 kPa)
Maximum operating pressure		25 psi (172 kPa)
Accuracy		2-1/2% of full scale for the middle half of the scale, 3-1/2% elsewhere
Scale ranges		See Tables 1, 2, and 3
Air connection		
1-1/2 inch		1/8-inch NPT external thread in center back
2-1/2 and 3-1/2 inch		Barbed fitting for 1/4-inch OD poly tubing
Dimensions		See Figures 1, 2, and 3
Weight		
1-1/2 inch		0.2 lb (0.09 kg)
2-1/2 inch		0.5 lb (0.2 kg)
3-1/2 inch		0.6 lb (0.3 kg)

Operation

As the air pressure increases, the curved bourdon tube, which has one end fixed, tends to straighten. This action moves the precision gear linkage that is attached to the end of the tube and, in turn, rotates the pointer in a clockwise direction. As the pressure decreases, the tube tends to return to its normal curved position, reversing the pointer's direction of movement.

**Table 1. Analog Receiver Gauges
(3 to 15 psi) - English Units.**

Range	Product No. for 1-1/2-in.	Product No. for 2-1/2-in.	Product No. for 3-1/2-in.
-40°F to +120°F	—	—	—
-40°F to +160°F	142-0430	—	—
-25°F to +135°F	—	—	—
-10°F to +65°F	—	—	—
0°F to 100°F	142-0316	142-0327	—
25°F to 250°F	—	—	—
30°F to 190°F	—	—	—
35°F to 135°F	142-0241	—	142-0288
40°F to 240°F	—	—	—
50°F to 100°F	—	—	—
50°F to 150°F	—	—	—
80°F to 240°F	—	—	—
160°F to 320°F	—	—	—
20% to 80 % rh	—	—	142-0283
0 psi to 50 psi	—	—	—
3 psi to 15 psi	—	—	—
-0.05 wg to +0.2 wg	—	—	—
-0.5 wg to + 0.5 wg	—	—	—
0 H ₂ O to 3" H ₂ O	—	—	—
0 to 10" wg	—	—	—
0 H ₂ O to 15" H ₂ O	142-0247	—	—
0 FPM to 2000 FPM	—	—	—
0 FPM to 3000 FPM	—	—	—
0 FPM to 4000 FPM	—	—	—
0 FPM to 5000 FPM	—	—	—

Table 2. Receiver Gauges - Metric Units.

Range	Product No. for 1-1/2-in.	Product No. for 2-1/2-in.	Product No. for 3-1/2-in.
-40 to +50°C	—	—	—
-20°C to 40°C	—	—	—
10°C to 38°C	—	—	—
25°C to 120°C	—	—	—
26.7°C to 116°C	—	—	—
20% to 80% rh	—	—	—
-12.5 Pa to +50 Pa	—	—	—
-125 Pa to +125 Pa	—	—	—
0 kPa to 345 kPa	—	—	—
0 kPa to 747 kPa	—	—	—
0 kPa to 2.5 kPa	—	—	—
0 m/sec to 20 m/sec	—	—	—

Table 3. Dual Gauges.

Range	Product No. for 1-1/2-in.	Product No. for 2-1/2-in.	Product No. for 3-1/2-in.
0 to 100 °F -20 to 40°C	—	—	142-0229
16 to 40 BTU/lb 37 to 93 kJ/kg	—	—	—

Installation

1-1/2-inch gauges have a 1/8-inch NPT external thread fitting for pipe mounting.

2-1/2 and 3-1/2-inch gauges are flush mounted on a panel. These have a barbed fitting for 1/4-inch OD poly tubing.

For panel cutout dimensions, see *TB 196, Cabinet Cutouts Technical Bulletin* (155-223).

Calibration

Measure the temperature (or humidity or pressure) that the transmitter is sensing. If the gauge does not indicate this measurement, adjust the gauge pointer.

1. Remove the gauge cover.
 - For a 1-1/2-inch gauge, pry the cover with a thin-blade screwdriver.
 - For a 2-1/2-inch or 3-1/2-inch gauge, unscrew the cover.
2. Hold the pointer stationary between two fingers.
3. Insert a screwdriver into the screw at the center of the pointer and rotate the screw. See Figure 1.
 - Rotate clockwise to decrease the indicated value.
 - Rotate counterclockwise to increase the indicated value.
4. Release the pointer and check the reading.
5. Repeat if necessary.

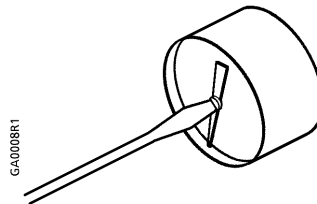

Figure 1. Adjusting the Gauge Pointer.

Dimensions in Inches (mm)

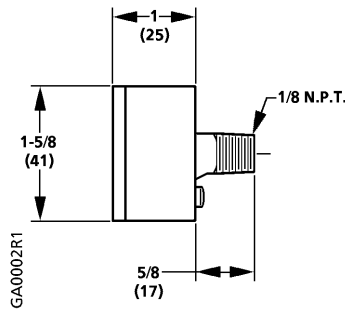

Figure 2. 1-1/2-Inch Gauge.

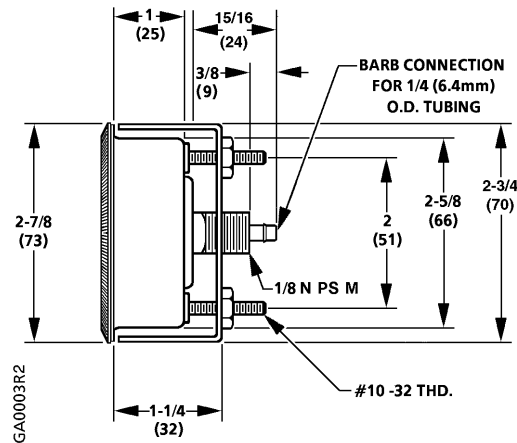

Figure 3. 2-1/2-Inch Gauge.

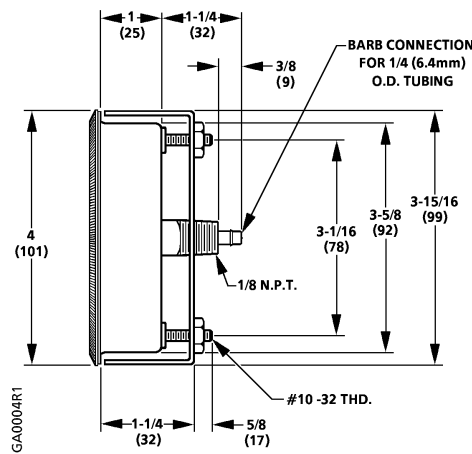

Figure 4. 3-1/2-Inch Gauge.

Information in this publication is based on current specifications. The company reserves the right to make changes in specifications and models as design improvements are introduced. POWERS is a trademark of Siemens Industry, Inc. Other product or company names mentioned herein may be the trademarks of their respective owners. © 2021-2023 Siemens Industry, Inc.