

POWERS®

TH 356 LIMITEM® Rigid Bulb Thermostat

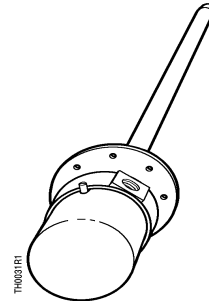

Description The TH 356 Rigid Bulb LIMITEM® is a pneumatically operated thermostat available either as direct acting or reverse acting in a variety of ranges.

- Features**
- Copper motor tube and invar steel rod sensing element
 - Two-valve design eliminates wasting of air
 - 18-inch (457 mm) bulb useful where stratification occurs
 - Flange, locknut and screws for duct mounting included

Product Numbers

Table 1.

Product Number	Operating Range	Action
356-0750	30 to 180°F (-1 to 82°C)	Direct Acting
356-0012	0 to 100°F (-18 to 38°C)	
356-1005	30 to 180°F (-1 to 82°C)	Reverse Acting
356-0013	0 to 100°F (-18 to 38°C)	

Application

The 356 Rigid Bulb LIMITEM is recommended for use in controlling duct air temperatures such as mixed air or discharge air. It can also be used as a high or low temperature limit control. In unit ventilator applications it is used as a low limit control. When used with a well, it can be used for water temperature control.

Specifications		
Operating range		See Table 1
Normal air supply pressure		18 or 25 psi (124 or 172 kPa)
Maximum supply air pressure		30 psi (207 kPa)
Maximum external pressure on bulb		250 psi (1,722 kPa)
Maximum ambient temperature		
case		200°F (93°C)
bulb		
30 to 180°F		225°F (107°C)
0 to 100°F		250°F (121°C)
Factory sensitivity setting		1-1/4 psi/F (15 kPa/C)
Sensitivity range adjustable		1/4 to 2 psi/F (3 to 25 kPa/C)
Temperature response		1/2°F (0.9°C)
Mounting		Flange or 3/8-inch NPT
Air connection		1/8-inch NPT
Shipping weight		2 lbs (0.9 kg)
Dimensions		
Bulb length		18 inches (457 mm)
Case		3 in. L x 1-1/2 in. diameter (76 mm x 38 mm)
Flange O.D.		2-9/16 in. (65 mm)

Accessory		
Swivel flange mounting kit		356-090

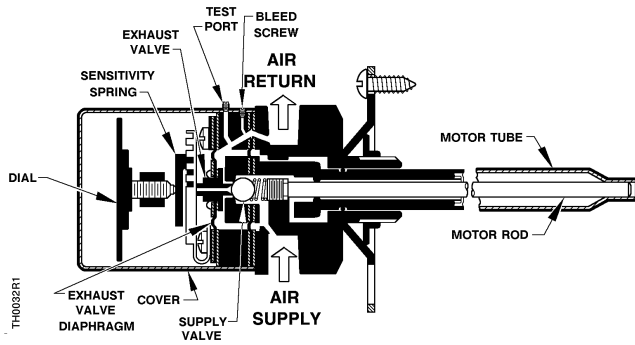

Figure 1. Direct Acting Operation.

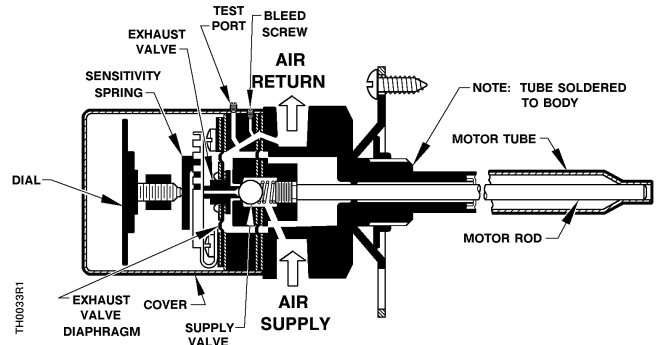

Figure 2. Reverse Acting Operation.

Operation The copper motor tube and invar steel rod average temperature changes by measuring the difference in expansion between the two metals. This positions the two-valve mechanism in response to the slightest temperature changes.

Direct Acting

As temperature increases, the motor tube expands and moves the supply valve away from the ball valve, causing a gradual increase of air pressure in the return line. (The ball valve is closed against the exhaust valve while the supply valve is open, preventing constant air waste.) Increased pressure in the return air chamber causes the exhaust valve diaphragm to compress the sensitivity spring. The exhaust valve is moved away from the ball valve, closing against the supply valve. This throttles the supply air in proportion to the temperature change established by the sensitivity spring.

As the temperature drops, the motor tube contracts. This moves the ball valve away from the exhaust valve and gradually reduces the return line air through the exhaust port. Lower pressures in the return air chamber force against the exhaust valve. The sensitivity spring expands and the exhaust valve moves gradually to the ball valve reducing the return air waste.

Reverse Acting

As temperature increases, the motor tube expands and moves the supply valve and the ball valve away from the exhaust valve, causing a gradual decrease of air pressure in the return line.

(The ball valve is closed against the supply valve while the exhaust valve is open, preventing air waste.) Decreased pressure in the return air chamber causes the exhaust valve diaphragm to allow the sensitivity spring to expand. The exhaust valve is moved toward the ball valve, closing both the exhaust and the supply valves against the ball. This throttles the supply air in an inverse proportion to the temperature change established by the sensitivity spring.

As the temperature drops the motor tube contracts, moving the ball valve away from the supply valve, gradually increasing the return line air supply valve port. Higher pressures in the return air chamber increase force against the exhaust valve diaphragm. The sensitivity spring compresses and the ball valve moves gradually to the supply valve reducing the supply air volume to the return air chamber.

The throttling range is changed by sliding the sensitivity spring. Sensitivity is most gradual 0.25 psi/1°F or 3.1 kPa/°C when the spring's open end is under the adjusting screw. Throttling is most positive 2psi/1°F or 24.8 kPa/°C when the solid end of the spring is under the adjusting screw. Factory setting is at the center of the sensitivity spring, or 1-1/4 psi/1°F or 15.5 kPa/°C. Any change to the spring's position offsets control and makes resetting of the dial necessary.

Return line vent, factory set for 5 to 7 CIM (1.37 to 1.91cm³/s), prevents the air being trapped in the line when the Limitem is piloted from a room thermostat.

Installation

Duct Mounting (See Figure 3.)

NOTE: Calibrate the LIMITEM® for your application after installation.

Flange, lock nut and sheet metal screws are provided for duct mounting.

1. Remove the flange from the LIMITEM and use the flange as a template. Mark the location of the center hole and three screw holes. Drill the holes.
2. Slip the flange over the rigid bulb and secure with the lock nut.
3. Fasten the Limitem to the duct with the sheet metal screws provided.
4. Attach air gauges and tees in the supply and return lines.

The installation is now complete.

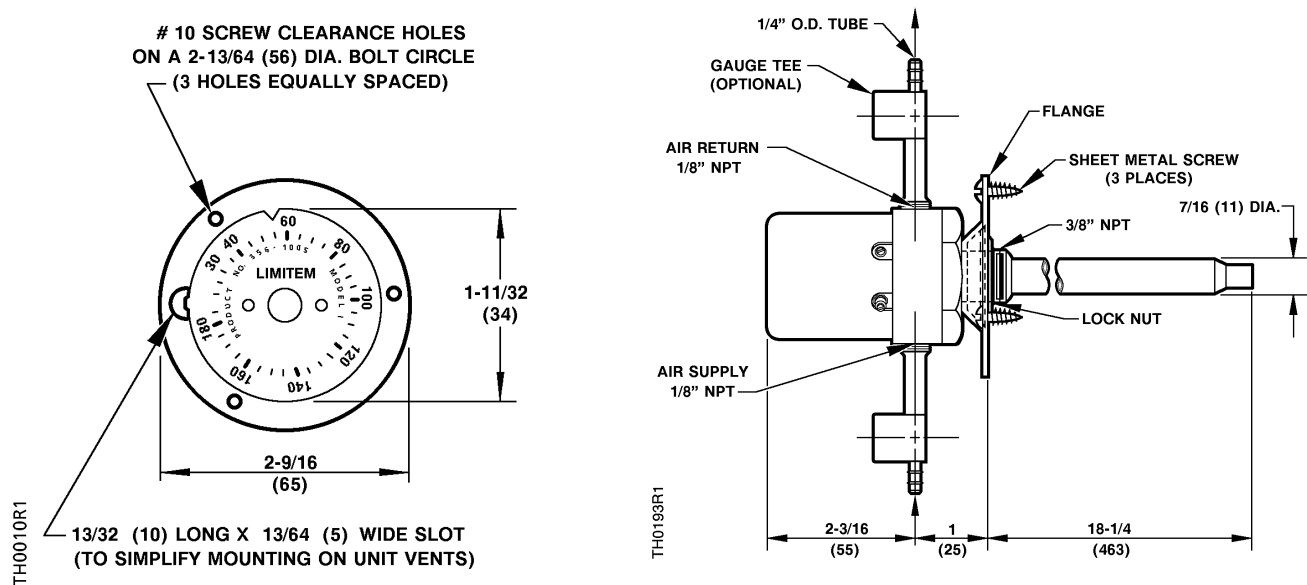

Figure 3. TH 356 Rigid Bulb LIMITEM.

Alternate Duct Mounting Swivel Flange Mounting. (See Figure 4.)

The swivel flange mounting kit Part No. 356-090 is available for mounting the LIMITEM in ducts as small as 13 inches (330 mm) wide.

1. Use the swivel flange as a template to mark the location of the center hole and three screw holes.
2. Drill the holes and attach the flange.
3. Remove the standard mounting flange from the Limitem.
4. Carefully thread the LIMITEM through the 3/8-inch NPT tapped swivel socket.
5. Fasten the flange to the duct with the sheet metal screws provided.

The installation is now complete.

**Installation,
 continued**

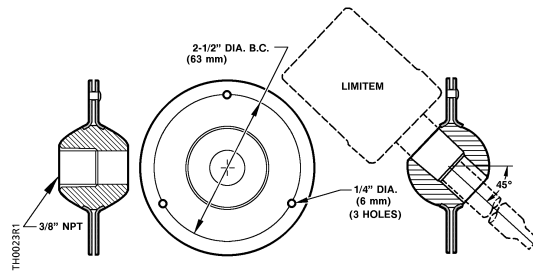

Figure 4. Swivel Flange Mounting Kit part No. 356-090.

Well Mounting

1. Exercise care when installing the limitem into a well.
2. The LIMITEM® must fit freely in the well to operate properly.
3. Screw the limitem into the well finger tight.
4. Tighten the set screw on the well to hold the LIMITEM securely.

The installation is now complete.

Calibration

1. Remove the cover.

To Change Setpoint

2. Turn the dial adjustment screw with a screwdriver to change to the desired setpoint. See Figure 5

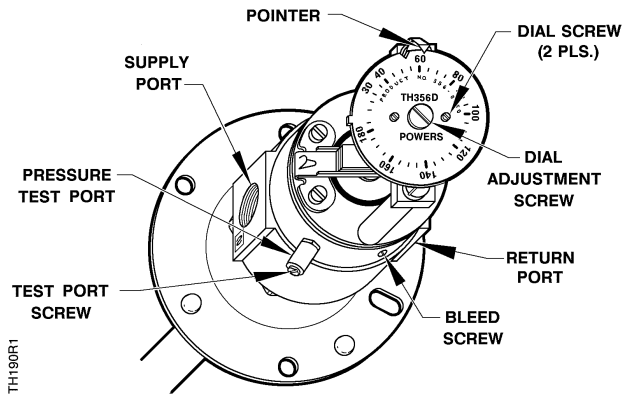

Figure 5. LIMITEM Cover Removed.

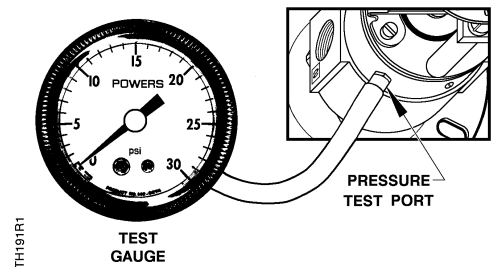

Figure 6. Using the Pressure Test Port.

Calibration, continued

To calibrate

1. Using a test thermometer, accurately measure the temperature at the bulb.
2. Set the dial to the bulb temperature by turning the dial adjustment screw with a screwdriver.

NOTE: You must use a screwdriver. Do not attempt to change the dial by rotating it with your hand.

3. If permanent return air gauge is not installed, use the pressure test port. See Figure 6 for its location.
4. Loosen the test port screw about 1/2 turn, and slip a 3/16-inch ID rubber hose connected to the test gauge over the pressure test port. See Figure 6.
5. If the return pressure does not read 7 to 8 psi (48-55 kPa), turn the dial adjustment screw with a screwdriver until pressure is 7 to 8 psi (48-55 kPa).
6. Loosen the dial screws and turn dial until the temperature at the bulb and dial is identical. Tighten the screws.

The thermostat is now calibrated and setpoint may be changed as desired.

Sensitivity Adjustment

The sensitivity adjustment is factory set with the sensitivity spring tab in position 6 of the spring retainer. This is approximately mid span of the sensitivity. Move the sensitivity spring to a lower slot number for more gradual setting. Move the sensitivity spring to a higher slot number for more positive setting. See Table 2.

To change the sensitivity:

1. Loosen the dial screws. (See Figure 5.)
2. Loosen the dial adjustment screw.
3. Lightly press, but do not bend the spring retainer. See Figure 7.
4. Move the sensitivity spring to the new position. See Figure 7. Table 2 gives the sensitivity spring tab location and the corresponding sensitivity value.

NOTE: The tab may be installed in either side of the spring retainer.

5. Make sure that the dial adjustment screw point touches the sensitivity spring.
6. Recalibrate the unit.
7. If you need to adjust again, allow five minutes for the control cycle to settle before repeating the steps above.

Sensitivity Adjustment, continued

Table 2.	
Slot No.	Sensitivity Psi/°F
1	0.29
2	0.44
3	0.64
4	0.89
5	1.03
6	1.22
7	1.41
8	1.61
9	1.80
10	2.0
11	2.0

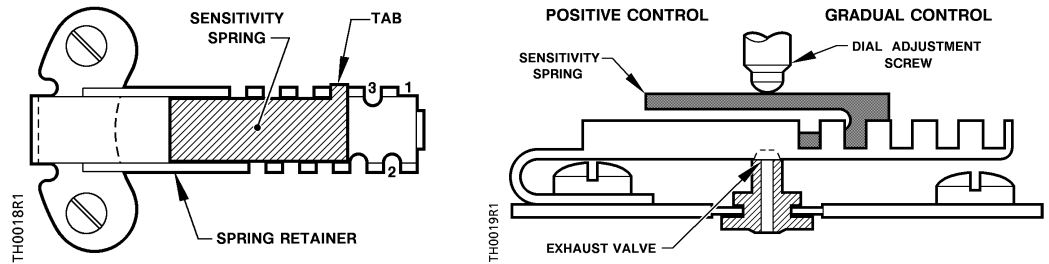

Figure 7. Sensitivity Spring Setting.

Troubleshooting

If the LIMITEM® fails to operate properly, use Table 3 as a troubleshooting guide. Make certain the thermostat receives 18 to 30 psi (124 to 207 kPa) of clean, dry, oil-free supply air. Also, use a test gauge with a length of 3/16" ID rubber hose to measure the return pressure at the test port if permanent gauges are not available.

Service

The LIMITEM cannot be serviced. Replace the thermostat if inoperative after checking the troubleshooting table.

Table 3. Troubleshooting Chart.

Complaint	Check	Probable Cause	Corrective Action
Return Line pressure stays at approximately zero	Supply air Pressure	Low Pressure	As Required
	Depress exhaust valve	If return is still zero psi	Defective valve assembly
If return pressure increases		Out of calibration or damaged sensing element	1. Recalibrate 2. With 6 to 9 psi return pressure, vary temperature at the bulb. If no change in return pressure, replace thermostat.
Return Line pressure stays at approx. supply pressure	Using a screwdriver, rotate setpoint dial counterclockwise to the limit stop	If return pressure remains high	Defective valve assembly Replace thermostat
		If return pressure drops to zero	Out of calibration Recalibrate
Excessive air leakage from exhaust valve	Supply and return line connection	Connections are interchanged	Reverse the supply and return connections
Temperature cycles rapidly	Sensitivity setting	Improper setting	Move the sensitivity spring to a more gradual (lower number) slot setting. See <i>Sensitivity Adjustment</i> .
Temperature wanders from control point	Sensitivity setting	Improper setting	Move the sensitivity spring to a more positive (higher number) slot setting. See <i>Sensitivity Adjustment</i> .

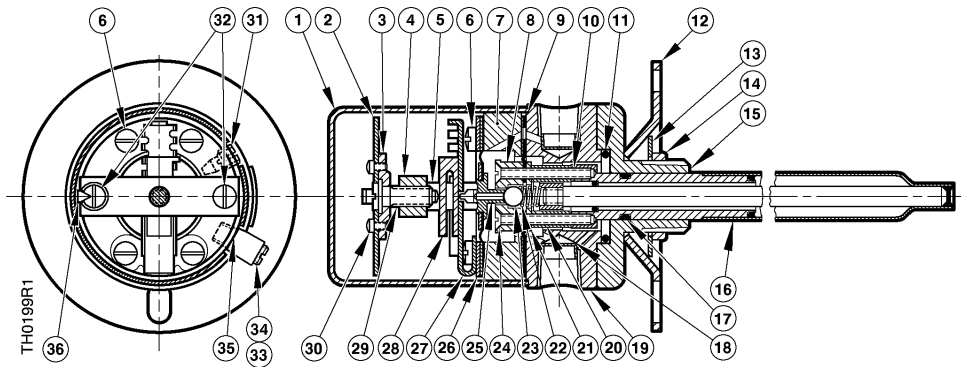

Figure 8. Construction of the Rigid Bulb LIMITEM®.

Table 4. Parts List.

Item	Part	Qty.	Part Number
1	Cover	1	—
2	Dial	1	—
3	Lock Plate	1	—
4	Bridge	1	—
5	Upper Spacer	2	—
6	No. 6-32 x 1-3/8" Lg.Fil. head screw	4	—
7	Housing Ring	1	—
8	Supply Valve	1	—
9	Supply Valve Diaphragm	1	—
10	No. 3-48 x 7/8" Lg.Fil. head Screw	2	—
11	110. Ring	1	—
12	Duct Flange	1	—
13	Washer	1	—
14	Locknut	1	—
15	Flange	1	—
16	Motor Tube Assembly	1	—
17	O-Ring	1	—
18	Screen Filter	2	—

Table 4. Parts List, continued.

Item	Part	Qty	Part Number
19	Body	1	—
20	Lower Spacer	2	—
21	Retaining Ring	1	—
22	Spring	1	—
23	Ball Valve	1	—
24	Sealing Gasket	2	—
25	Supply Valve Body	1	—
26	Diaphragm Ring	1	—
27	Retaining Spring	1	—
28	Sensitivity Spring	1	—
29	Dial Adjustment Screw	1	—
30	Dial Screws	2	—
31	Bleed Screw	1	—
32	No. 6-32 x 1-7/8" Lg.Fil. head machine screw	2	—
33	Test Plug	1	—
34	Test Valve Body	1	—
35	Valve Gasket	1	—
36	Pointer	1	—

Information in this publication is based on current specifications. The company reserves the right to make changes in specifications and models as design improvements are introduced. POWERS and LIMITEM are registered trademarks of Siemens Industry, Inc. Other product or company names mentioned herein may be the trademarks of their respective owners. © 2015-2022 Siemens Industry, Inc.