

Flowrite™ 599 Series

SKB/C Electronic Valve Actuator Proportional Control

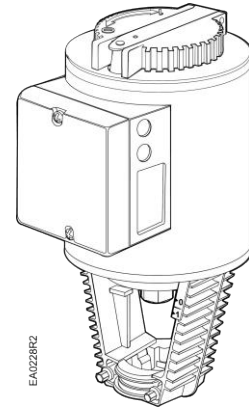

Description

The Flowrite 599 Series SKB/C Electronic Valve Actuator requires a 24 Vac supply and receives a 0 to 10 Vdc or a 4 to 20 mA control signal to proportionally control a valve. This actuator is designed to work with Flowrite 599 Series valves with a 3/4-inch (20 mm) or 1-1/2-inch (40 mm) stroke.

Features

- Direct-coupled installation requires no special tools or adjustments
- Visual and electronic stroke indication
- Die-cast aluminum housing
- Manual override
- Spring return to fail-safe position
- Automatic stroke calibration
- Maintenance-free



Application

These electronic actuators are designed to be used with Flowrite 599 Series valves with 3/4-inch (20 mm) stroke (SKB) and 1-1/2 inch (40 mm) stroke (SKC) in liquid and steam service applications.

Product Numbers

Actuator Stroke	Order Number	Actuator Prefix Code
3/4-inch (20 mm)	SKB62U	291
1-1/2 inch (40 mm)	SKC62U	294

Warning/Caution Notations

WARNING:		Personal injury/loss of life may occur if you do not perform a procedure as specified.
CAUTION:		Equipment damage or loss of data may occur if you do not follow a procedure as specified.

Specifications	Operating voltage SKB/C62U	24 Vac \pm 20%	
	Frequency SKB/C62U	50/60 Hz	
Power Supply	Power consumption		
	SKB62U	18 VA/12W	
	SKC62U	28 VA/20W	
Control signal	Control input (Y) SKB/C62		
	Voltage	0 to 10 Vdc or 4 to 20 mA	
	Maximum Impedance	0 to 10 Vdc, 100K ohms 4 to 20 mA, 250 ohms	
	Control input (Z) SKB/C62U		
	Resistance	0 to 1000 ohms	
	Voltage	0 to 1.6 Vdc	
Feedback signal	Control output (U) SKB/C62U		
	Voltage	0 to 10 Vdc	
	Load impedance	>500 ohms	
	Current	4 to 20 mA	
	Load impedance	<500 ohms	
Equipment rating	Rating SKB/C62U	Class 2 according to UL, CSA	
Function	Nominal stroke		
	SKB62U	3/4-inch (20 mm)	
	SKC62U	1-1/2 inches (40 mm)	
	Run time with control operation (full stroke)		
	SKB62U	<u>Open/Close</u> 120 seconds	<u>Spring Return</u> 15 seconds
	SKC62U	120 seconds	20 seconds
	Nominal Force SKB/C62U	Stroke	Force
	NC and 3-way upper	0%	640 lbs (2800 N)
NO and 3-way by-pass	100%	1000 lbs (4400 N)	
Housing	Mounting location	NEMA 1 (interior only) NEMA TYPE 3R rated when installed with 599-10065 weather shield. See <i>Accessories</i> .	
Ambient conditions	Ambient temperature (Operation)	5°F to 130°F (-15°C to 55°C)	
	Media temperature	20°F to 337°F (-7°C to 170°C)	
Agency certification	UL	UL873	
	cUL Certified to Canadian standard	C22.2 No. 24-93	
	CE Conformity as per the EMC directive	89/336/EEC	
	Low voltage directive	78/23/EEC	

Specifications, continued	Conduit opening	1/2-inch NPSM
	Dimensions	See Figure 18
	Weight	
Miscellaneous	SKB62U	18.9 lbs (8,6 kg)
	SKC62U	22 lbs (10,0 kg)

Accessories Installation instructions are included with each accessory.

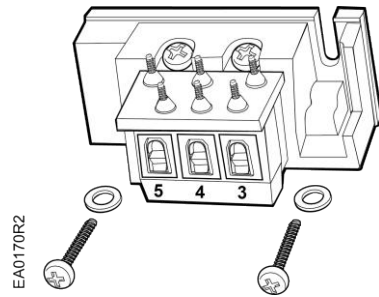

Figure 1. Auxiliary Switch.

ASC1.6 Auxiliary switch sends a signal to indicate the valve is in the 0% stroke position. Switching point is fixed at the 0% stroke position.

Switching capacity	24 Vac 4A resistive, 2A inductive
Lowest recommended current	10 mA

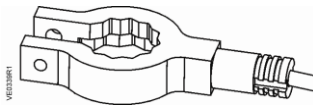

Figure 2. Stem Heating Element.

ASZ6.6 The stem heating element prevents the formation of ice on the stem when the medium temperature drops below 32°F (0°C). It is suited for universal use with valves having a stem or spindle diameter of 10 or 14 mm.

Operating voltage	24 Vac/dc ± 20%
Power consumption	≤ 40 VA/30W

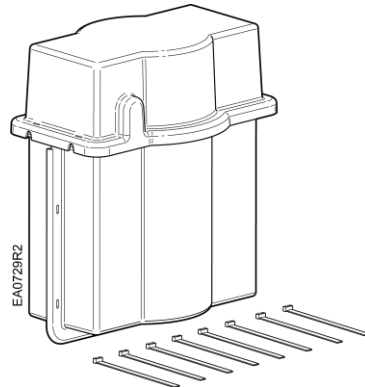

Figure 3. Weather Shield.

599-10065 The SKB/C actuator is UL listed to meet NEMA Type 3R requirements (a degree of protection against rain, sleet, and damage from external ice formation) when installed with Weather Shield and outdoor-rated conduit fittings in the vertical position. See *Service Kits* for replacement ultraviolet resistant cable ties.

Service Kits

Circuit board replacement	4 668 5748 8
Manual override kit	4268 5510 8
Plastic wiring compartment cover	4 104 5582 8
Stem retainer kit	
Contains one stem nut (Figure 6, Item 6) and one stem retainer clip.	
2-1/2 and 3-inch valves	599-10048
4, 5, and 6-inch valves	599-10049
Retainer clamp kit	599-10200
Ultraviolet (UV) resistant cable ties (pkg. of 8)	538-994



WARNING:

This product contains a spring under high compression. Do not attempt to disassemble the actuator.

Operation

A 0 to 10 Vdc or a 4 to 20 mA control signal controls the actuator. The actuator, mounted on a valve, produces a stroke proportional to the input signal. When power is turned off or in the event of a power failure, the actuator spring returns the valve to its normal position.

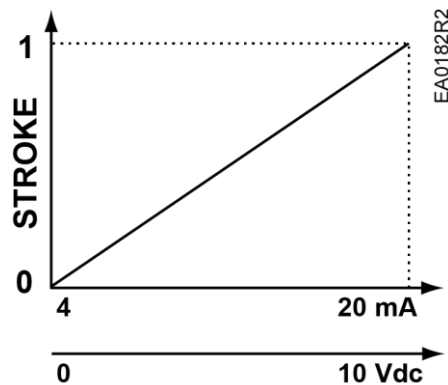

Figure 4. Input Signal.

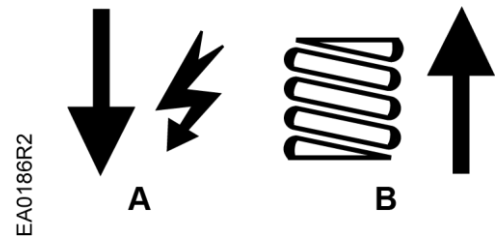

Figure 5. Spring Return.

SKB/C Details

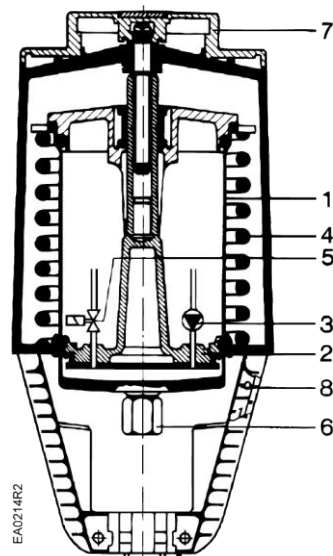

Figure 6. Actuator Design.

Legend

1. Pressure cylinder
2. Piston
3. Oscillating pump
4. Return springs
5. Bypass valve
6. Coupling piece (stem nut)
7. Manual setting knob
8. Position indicator

Mounting and Installation

The vertical position is the required position for mounting and the only position for NEMA Type 3R rating with the Weather Shield. Acceptable mounting positions are shown in Figure 7.

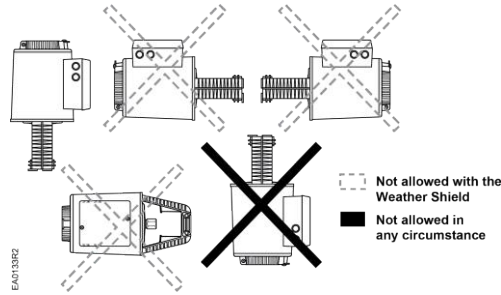

Figure 7. Acceptable Mounting Positions.

Allow four inches (100 mm) around the sides and back of the actuator and eight inches (200 mm) above and to the front of the actuator.

See dimensions in Figure 17 and Figure 18.

Detailed installation instructions for field mounting are shipped with the actuator.

CAUTION:



Use care when removing the knockout. Do not damage the circuit board. Use the top knockout position, if possible.

Start up

Check the wiring for proper connections.

NOTE: The valve body assembly determines the complete assembly action.

Override Control

The override control input (Z) has three modes of operation:

No Function	Override with 0 ... 1000 Ω
<p>Stroke</p> <p>100 % H_{max} H_{min} Y</p> <ul style="list-style-type: none"> - Z-Contact not Wired - Valve Stroke Follows Control Signal Y 	<p>Stroke</p> <p>100 % 0 % 50 900 R [Ω]</p> <ul style="list-style-type: none"> - Z-Contact Connected to M Via Resistor R - Linear or Equal-Percentage Characteristic - Starting Position at 50 / End Position at 900 - Y-Input has No Effect
Actuator Fully Extended	Actuator Fully Retracted
<p>Stroke</p> <p>100 % V_{max} 0 % Y</p> <ul style="list-style-type: none"> - Z-Contact Connected Directly to G - Y-Input has No Effect 	<p>Stroke</p> <p>100 % V_{max} 0 % Y</p> <ul style="list-style-type: none"> - Z-Contact Connected Directly to GO - Y-Input has No Effect

NOTE: The Z-modes have a direct acting factory setting.

**Start-up,
 continued**

Stroke Calibration

To determine the stroke positions 0% and 100% in the valve, calibration is required when the valve/actuator are commissioned for the first time. The actuator must be mechanically connected to a valve and must have a supply voltage of 24 Vac. Repeat the calibration procedure as often as necessary



CAUTION:

Before starting calibration, be sure that the manual adjuster is set to **Automatic** for the actual values to register.

There is a slot on the printed circuit boards for the actuators. To initiate the calibration procedure, the contacts inside this slot must be short-circuited (possibly with a screwdriver). See Figure 8.

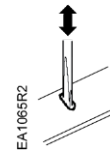
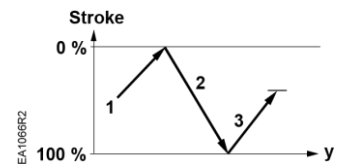

Figure 8.

Automatic calibration proceeds as follows (see Figure 9):

- Actuator runs to the 0% stroke position (1), green LED flashes.
- Actuator then runs to the 100% stroke position (2), green LED flashes.
- Measured values are stored in the EPROM.
- The actuator now moves to the position defined by control signal Y or Z (3), and the green LED now glows steady (normal operation).
- Throughout this procedure, output U is inactive, meaning the values only represent actual positions when the green LED stops flashing and remains on continuously.



**Figure 9.
 Automatic Calibration**

Table 1. LED Status.

LED	Display	Function	Action
Green	ON	Normal Operation	Automatic operation
	Flashing	Stroke calibration In Progress	Wait for calibration to be completed (LED stops flashing)
Red	ON	Faulty stroke calibration	- Check mounting - Restart stroke calibration (by short-circuiting calibration slot) - Replace electronics
	Flashing	Internal Error	Check the valve
	OFF	<ul style="list-style-type: none"> • No power supply • Faulty electronics 	-Check mains -Replace electronics

**Start-up,
 Continued**

Standard Features

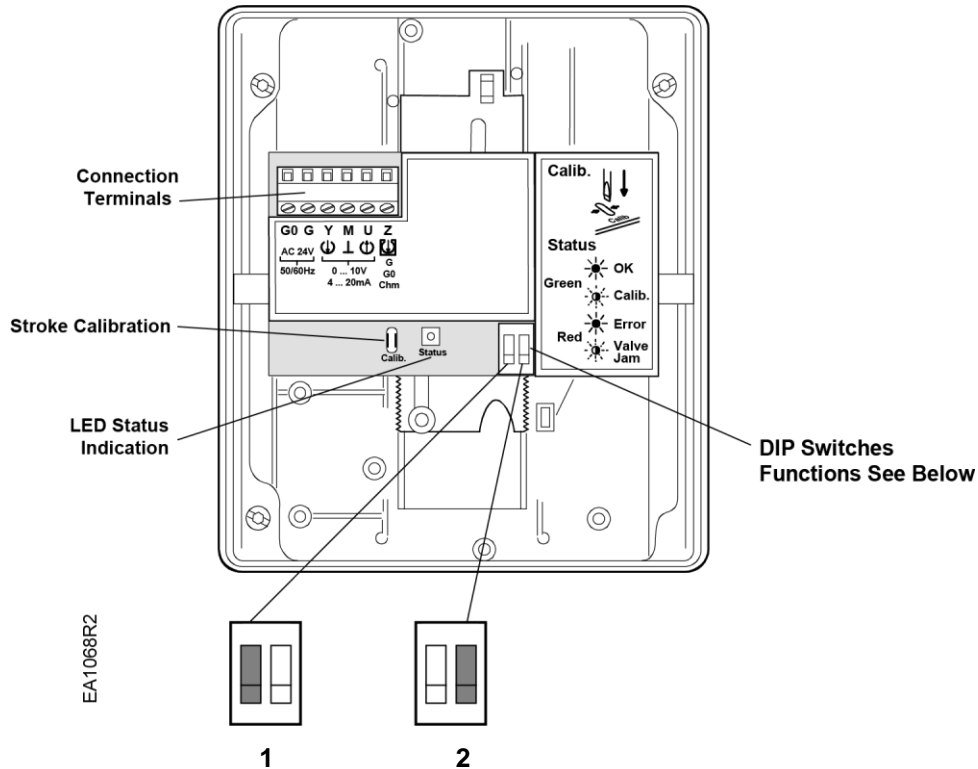

Figure 10. DIP Switches.

DIP Switches (From Left to Right)	1 Selection of Control Signal	2 Selection of Flow Characteristic
ON	4 to 20 mA	Modified*
OFF (Factory Settings)	0 to 10 Vdc	Default

* Changing the default setting will modify an equal percentage valve to a linear flow characteristic. When set to default, the flow characteristic is determined by the valve body.

Normally Closed Valve Actuator pressure cylinder moves:

- Outward (**0 to 1**): Valve opens.
- Inward (**1 to 0**): Valve closes.

Normally Open Valve Actuator pressure cylinder moves:

- Outward (**0 to 1**): Valve closes.
- Inward (**1 to 0**): Valve opens.

**Start-up,
 continued**

Three-way Valve

Actuator pressure cylinder moves:

- Outward (0 to 1): Valve opens between ports NC and C.
- Inward (1 to 0): Valve opens between ports NO and C.

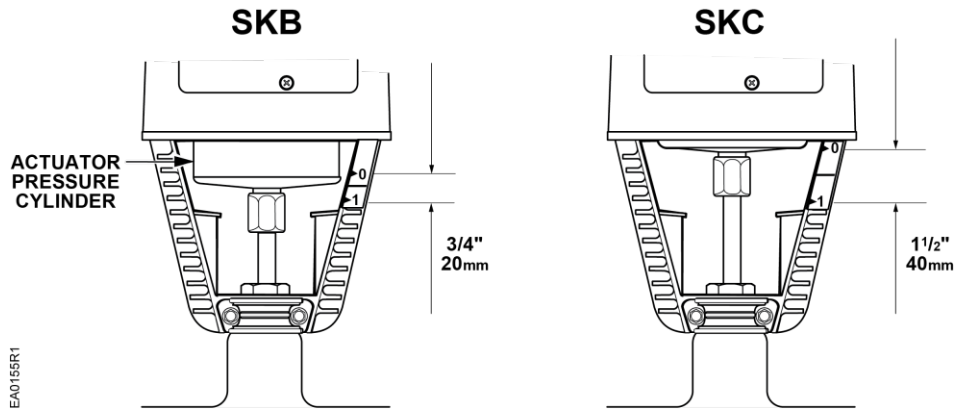

Figure 11. Valve Stem Travel Indication.

Manual operation

Release the crank arm of the manual setting knob located on the top of the actuator. See Figure 12.

A red scale appears in a window in the manual setting knob as you turn the crank clockwise, (see Figure 12). This scale indicates the effective valve stroke in millimeters.

Each complete revolution (360°) is equal to 2 mm of stroke. The numbers 2 to 20 or 2 to 40 are visible depending on the stroke of the actuator.

If a signal is sent to the actuator while it is in manual operation, the actuator will move but the control will not be accurate. The valve cannot be commanded to its 0% position while in manual operation.

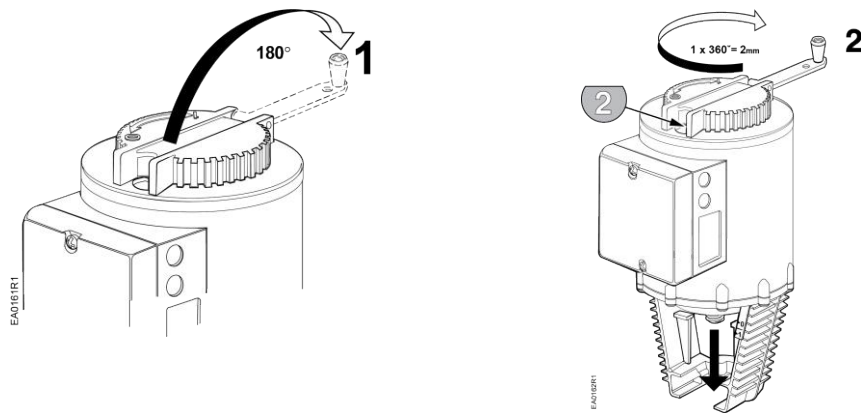

Figure 12. Manual Operation.



CAUTION:

Do not attempt automatic operation of the actuator when the red scale is visible.

Automatic operation

When returning to automatic control, turn the crank arm of the manual setting knob counterclockwise until the red numbers disappear. It is essential that the window is clear and the crank arm is snapped into position. See Figure 13.

NOTE: It is possible to secure the manual override handle in place by inserting a # 8 x 1-1/4-inch or M5 x 30 mm thread-forming screw through the handle.

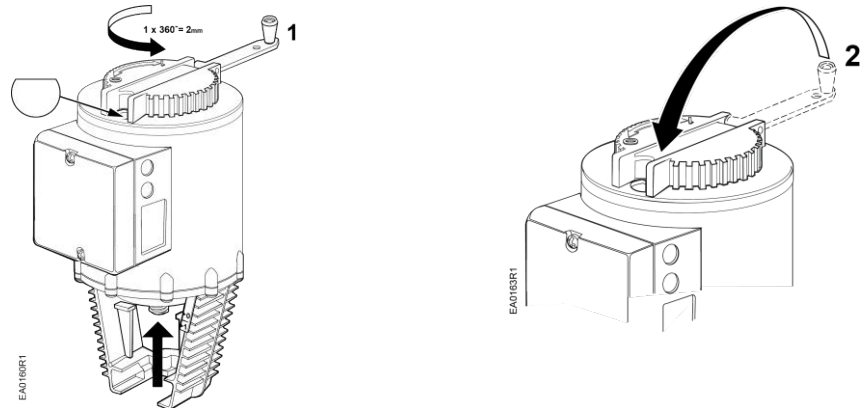

Figure 13. Automatic Operation.

Wiring

Do not use autotransformers. Use earth ground isolating step-down Class 2 transformers.

Determine supply transformer rating by summing total VA of all actuators used. The maximum rating for Class 2 step-down transformer is 100 VA.

Actuator	Power Consumption	Actuators per Class 2 Supply Circuit* (80% of transformer VA)
SKB62U	17 VA	4
SKC62U	28 VA	2

* Operating more actuators requires additional transformers or separate 100 VA power supplies.

Wiring Diagrams

The position output signal U will switch from 0 to 10 Vdc to 4 to 20 mA when a 4 to 20 mA input signal is selected and used on the Y terminal.

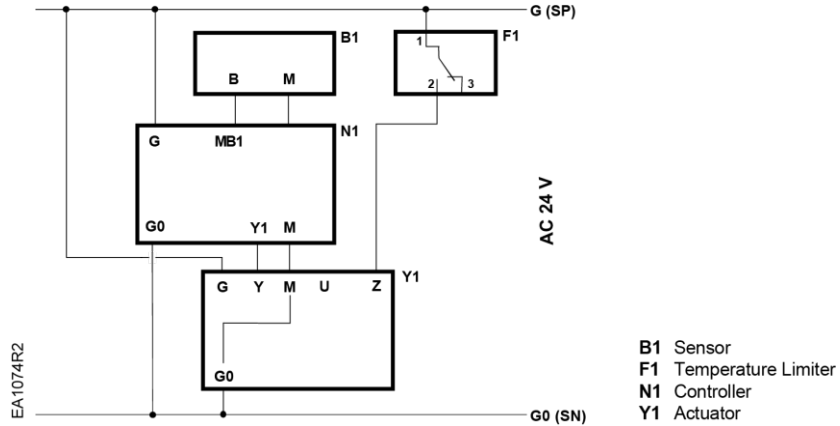

Figure 14. Connecting Terminals.

24 Vac	
G	System potential (SP)
G0	System neutral (SN)
Y	Control input 0 to 10 Vdc or 4 to 20 mA (DIP switch selectable)
Z	Override control
M	Measuring neutral
U	Output for 0 to 10 Vdc or 4 to 20 mA measuring voltage. See Table 1.

Table 1. Actuator Output Signal.

Actuator Input Signal	Receiving Impedance	
	Low (<500 ohm)	High (>10K ohm)
0 to 10 Vdc	0 to 20 mA	0 to 10 Vdc
4 to 20 mA	4 to 20 mA	2 to 10 Vdc

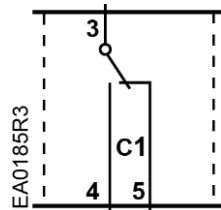

Figure 15. Auxiliary Switch ASC1.6.

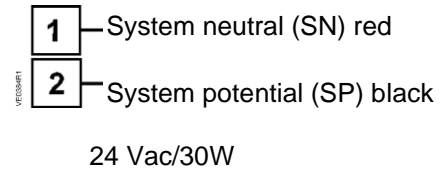

Figure 16. Stem Heating Element ASZ6.6.

Dimensions

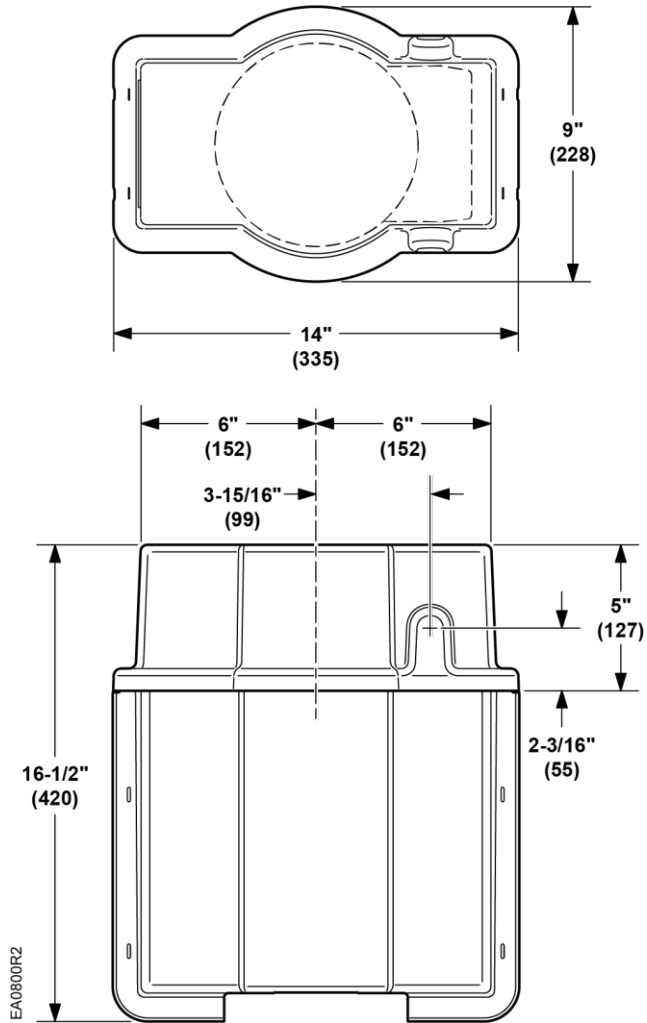

Figure 17. Dimensions of the 599-10065 Weather Shield in Inches (Millimeters).

**Dimensions,
 Continued**

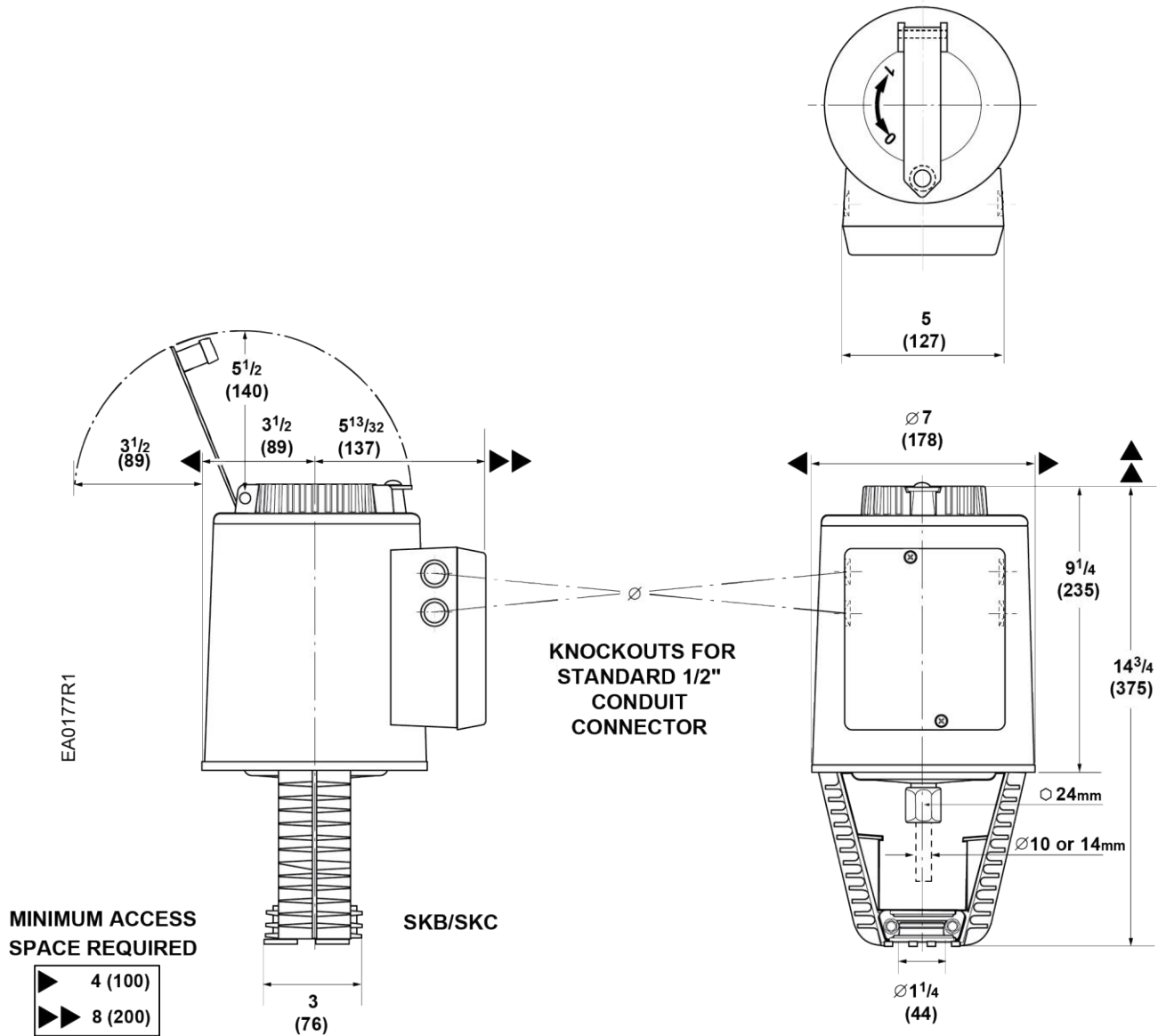

Figure 18. Dimensions of SKB/C in Inches (Millimeters).

Information in this publication is based on current specifications. The company reserves the right to make changes in specifications and models as design improvements are introduced. Flowrite is a trademark of Siemens Industry, Inc. Other product or company names mentioned herein may be the trademarks of their respective owners. © 2018-2025 Siemens Industry, Inc.