

Powermite 599 Series

MT Series Terminal Unit

Two-way Valves

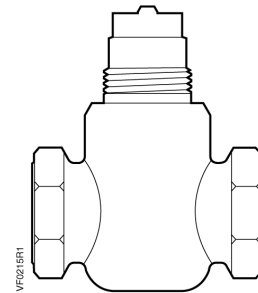

Description	The Powermite 599 Series ANSI Class 250 MT Series two-way valve bodies work with any MT Series pneumatic or electronic actuator with a 7/32-inch (5.5 mm) stroke.	
Features	<ul style="list-style-type: none"> • Direct coupled universal bonnet • Choice of brass or stainless-steel trim • ANSI Leakage Class IV (0.01% of Cv) 	
Application	A typical application for the Powermite two-way valve is the control of hot or chilled water or low pressure (<15 psi with stainless steel trim only) steam for convectors, fan coil units, unit conditioners, radiation, reheat coils, and similar terminal units requiring an actuator that delivers a minimum of 67 pounds force (300 N).	
Product Numbers	See Table 2.	
Ordering a Valve Plus Actuator Assembly	To order a complete valve plus actuator assembly from the factory, combine the actuator prefix code with the suffix of the valve assembly product number. See <i>Technical Bulletin TB251</i> (155-306P25) for selection procedure and ordering codes.	
	Valve assemblies can be ordered using the numbers in Table 2.	
Specifications	Valve size	1/2 inch to 1 inch (15 mm to 25 mm)
	Capacity	See Tables 3 through 6 and Figure 1
	Body style	Globe
	Seat style	Metal-to-metal
	Action	Normally open/normally closed
	Valve body rating	ANSI Class 250; See Table 1.
	Stem travel (Stroke)	7/32-inch (5.5 mm)

Table 1. Body Temperature-Pressure Rating.

Valve Body	Temperature		Pressure	
	°F	°C	psig	(kPa)
Bronze/ Forged Brass	-20 to 150	(-30 to 66)	400	(2758)
	200	(93)	385	(2655)
	250	(121)	365	(2586)
	300	(149)	335	(2300)
	350	(177)	300	(2068)

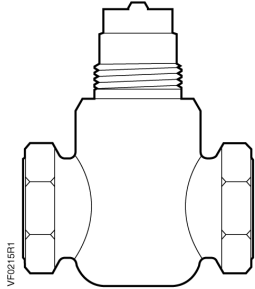

**Internal Thread NPT x
 Internal Thread NPT
 ITxIT**

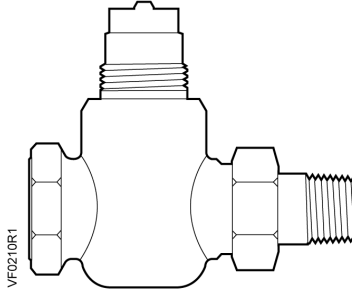

**Internal Thread NPT x
 Union External Thread
 ITxUET**

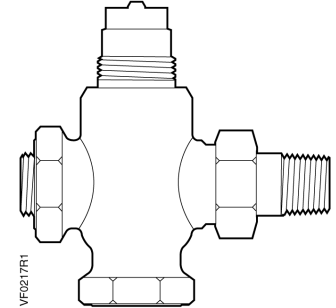

**Angle Internal Thread x
 Union External Thread
 AITxUET**

Table 2. Product Part Numbers.

Action	Flow Rate		Nominal Valve Size		Trim and Connection					
	Cv	(Kvs)	Inches	(mm)	Stainless Steel			Brass		
					ITxIT	ITxUET	AFxUM	ITxIT	ITxUET	AITxUET
Normally Closed	0.4	(0.34)	1/2	(15)	599-02015	599-02016	—	599-02000	599-02001	—
	0.63	(0.54)	1/2	(15)	599-02017	599-02018	—	599-02002	599-02003	—
	1.0	(0.85)	1/2	(15)	599-02019	599-02020	—	599-02004	599-02005	—
	1.6	(1.37)	1/2	(15)	599-02021	599-02022	—	599-02006	599-02007	—
	2.5	(2.15)	1/2	(15)	599-02023	599-02024	—	599-02008	599-02009	—
	4.0	(3.44)	1/2	(15)	599-02025	599-02026	—	599-02010	599-02011	—
	6.3	(5.43)	3/4	(20)	599-02027	599-02028	—	599-02012	599-02013	—
	10	(8.6)	1	(25)	599-02029	—	—	599-02014	—	—
Normally Open	0.4	(0.34)	1/2	(15)	599-02047	599-02048	—	599-02030	599-02031	—
	0.63	(0.54)	1/2	(15)	599-02049	599-02050	—	599-02032	599-02033	—
	1.0	(0.85)	1/2	(15)	599-02051	599-02052	—	599-02034	599-02035	—
	1.6	(1.37)	1/2	(15)	599-02053	599-02054	—	599-02036	599-02037	—
	2.5	(2.15)	1/2	(15)	599-02055	599-02056	599-02057	599-02038	599-02039	599-02040
	4.0	(3.44)	1/2	(15)	599-02058	599-02059	599-02060	599-02041	599-02042	599-02043
	6.3	(5.43)	3/4	(20)	599-02061	599-02062	—	599-02044	599-02045	—
	10	(8.6)	1	(25)	599-02063	—	—	599-02046	—	—

Table 3. Maximum Water Capacity - U.S. Gallons per Minute.

Valve Size Inches	Pressure Differential - psi															
	Cv\1	2	3	4	5	6	8	10	15	20	25	30	40	50	60	75
1/2	0.4	0.6	0.7	0.8	0.9	1.0	1.1	1.3	1.5	1.8	2.0	2.2	2.5	2.8	3.1	3.5
	0.63	0.9	1.1	1.3	1.4	1.5	1.8	2.0	2.4	2.8	3.2	3.5	4.0	4.5	4.9	5.5
	1.0	1.4	1.7	2.0	2.2	2.5	2.8	3.2	3.9	4.5	5.0	5.5	6.3	7.1	7.8	8.7
	1.6	2.3	2.8	3.2	3.6	3.9	4.5	5.1	6.2	7.2	8.0	8.8	10.1	11.3	12.4	13.9
	2.5	3.5	4.3	5.0	5.6	6.1	7.1	7.9	9.7	11.2	12.5	13.7	15.8	17.7	19.4	22
	4	5.7	7	8.0	8.9	10	11.3	12.6	15.5	17.9	20.0	21.9	25	28	31	35
3/4	6.3	8.9	10.9	12.6	14.1	15.4	17.8	20	24	28	32	35	40	45	49	55
1	10	14.1	17.3	20	22	24	28	32	39	45	50	55	63	71	77	87

Table 4. Maximum Water Capacity - Cubic Meters per Hour (m³/hr).

mm	Valve Size								Pressure Differential - kPa						
	1	10	20	30	40	50	60	80	Kvs/100	150	200	300	400	500	
15	0.03	0.11	0.15	0.19	0.22	0.24	0.26	0.30	0.34	0.42	0.48	0.59	0.68	0.76	
	0.05	0.17	0.24	0.30	0.34	0.38	0.42	0.48	0.54	0.66	0.76	0.94	1.08	1.21	
	0.09	0.27	0.38	0.47	0.54	0.60	0.66	0.76	0.85	1.0	1.2	1.5	1.7	1.9	
	0.14	0.43	0.61	0.75	0.87	0.97	1.06	1.23	1.37	1.7	1.9	2.4	2.7	3.1	
	0.21	0.68	0.96	1.17	1.35	1.51	1.66	1.91	2.15	2.6	3.0	3.7	4.3	4.8	
	0.34	1.1	1.5	1.9	2.2	2.4	2.7	3.1	3.4	4.2	4.9	6.0	6.9	7.7	
20	0.54	1.7	2.4	3.0	3.4	3.8	4.2	4.9	5.4	6.7	7.7	9.4	10.9	12.1	
25	0.86	2.7	3.8	4.7	5.4	6.1	6.7	7.7	8.6	10.5	12.2	14.9	17.2	19.2	
32	1.4	4.4	6.2	7.6	8.7	9.8	10.7	12.3	13.8	16.9	19.5	23.9	27.6	30.9	
40	2.2	6.8	9.6	11.8	13.6	15.2	16.7	19.2	22	26	30	37	43	48	

Table 5. Maximum Steam Capacity - Pounds per Hour.

Valve Size Inches	Inlet Pressure - psig																
		2		5				10				15					
	Pressure Differential - psi																
	Cv/1	1	2	1	2	3	4	5	2	4	6	8	10	6	9	12	15
1/2	0.4	4.8	6.7	5.2	7.3	8.8	10.0	11.0	8.2	11.3	13.6	15.3	16.7	15.0	17.9	20.0	21.6
	0.63	7.5	10.5	8.2	11.4	13.8	15.7	17.4	12.9	17.8	21.3	24.1	26	23.7	28.2	32	34
	1.0	12.0	16.6	13.0	18.2	22	25	28	20	28	34	38	42	38	45	50	54
	1.6	19.1	27	21	29	35	40	44	33	45	54	61	67	60	72	80	86
	2.5	30	42	33	45	55	62	69	51	71	85	96	104	94	112	125	135
	4	48	67	52	73	88	100	110	82	113	136	153	167	150	179	200	216
3/4	6.3	75	105	82	114	138	157	174	129	178	213	241	263	237	282	316	341
1	10	120	166	130	182	219	250	275	204	283	339	382	417	376	447	501	541

Table 6. Steam Capacity - Kilograms per Hour.

Valve Size mm	Inlet Pressure - kPa					
		50		100		
	Pressure Differential - kPa					
	Kvs	10	25	10	20	50
15	0.34	1.7	2.7	2.4	3.4	5.4
	0.54	2.7	4.3	3.8	5.4	8.5
	0.85	4.3	6.8	6	8.5	14
	1.37	6.9	10.8	10	14	22
	2.15	10.7	17	15	21	34
	3.4	17	27	24	34	54
20	5.4	27	43	38	54	85
25	8.6	43	68	60	85	135

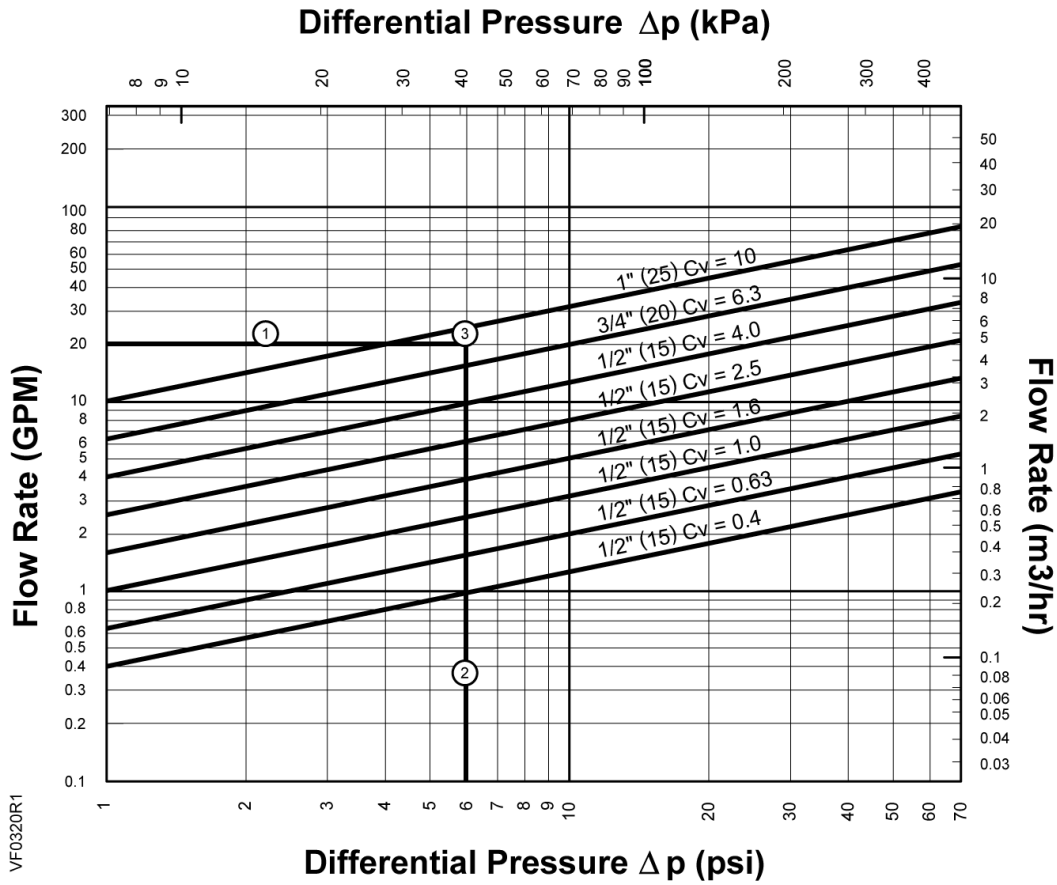

Figure 1. Water Capacity Graph.

Selection Example Select a valve given:

See Figure 1.

- ① Required flow = 20 gpm.
- ② Desired pressure drop = 5 psi.
- ③ Choose a 1-inch (25-mm) valve, Cv 10.

Table 7. Close-off Pressures for Electronic Actuators.

Action	Valve Size Inches (mm)	SAS psi (kPa)	SSC psi (kPa)
NC	1/2 0.4 < Cv < 1.6 (15) (0.34 < Kvs < 1.37)	95 (655)	95 (655)
	1/2 2.5 < Cv < 4 (15) (2.15 < Kvs < 3.44)	50 (345)	50 (345)
	3/4 (20)	40 (276)	40 (276)
	1 (25)		
NO	1/2 0.4 < Cv < 1.6 (15) (0.34 < Kvs < 1.37)	160 (1103)	120 (828)
	1/2 2.5 < Cv < 4 (15) (2.15 < Kvs < 3.44)	85 (586)	65 (448)
	3/4 (20)	70 (482)	55 (379)
	1 (25)		

Table 8. Maximum Available Close-off Pressures for Pneumatic Actuators.

Action	Valve Size Inches (mm)	2-inch Actuator @ 0 psi (0 kPa) (with 10 to 15 psi Valve)
NC	1/2 0.4 < Cv < 1.6 (15) (0.34 < Kvs < 1.37)	95 (655)
	1/2 2.5 < Cv < 4 (15) (2.15 < Kvs < 3.44)	50 (345)
	3/4 (20)	40 (276)
	1 (25)	
		@ 20 psi (103 kPa) (with 3 to 8 psi Valve)
NO	1/2 0.4 < Cv < 1.6 (15) (0.34 < Kvs < 1.37)	95 (655)
	1/2 2.5 < Cv < 4 (15) (2.15 < Kvs < 3.44)	45 (310)
	3/4 (20)	35 (241)
	1 (25)	

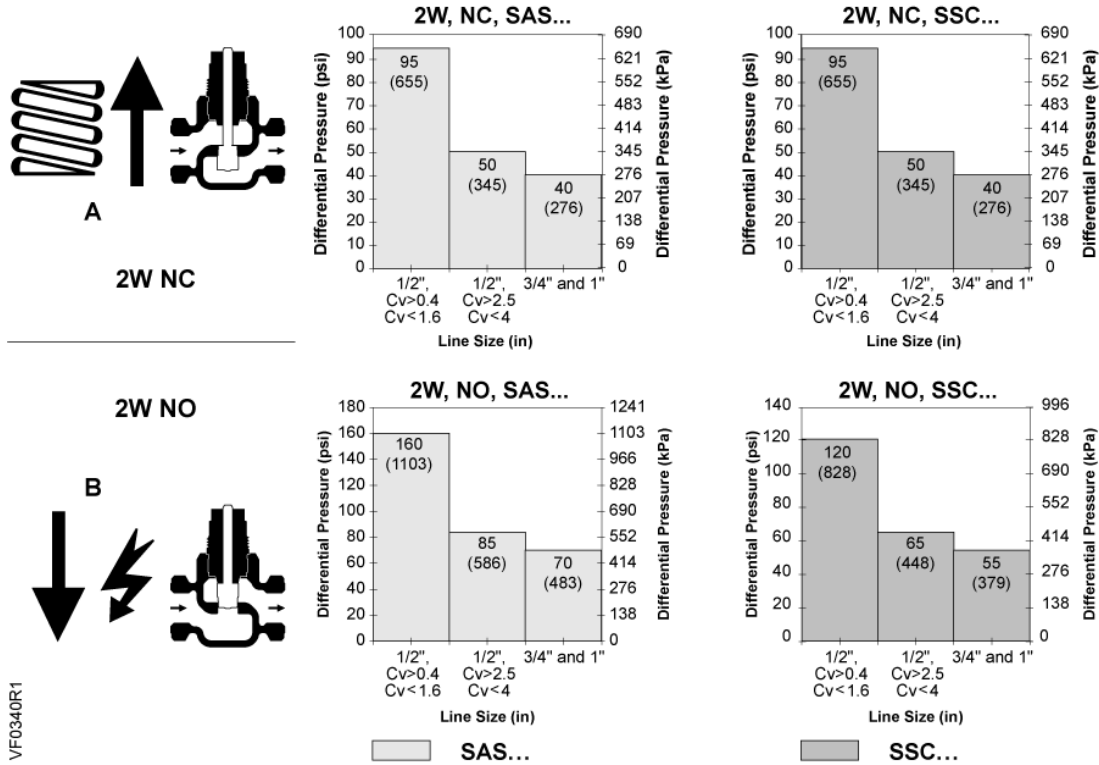

Figure 2. Close-off Pressures.

Operation

Figure 3 shows the normally open valve in the open or full flow position and the normally closed valve in the closed or zero flow position. The valve spring provides the necessary force to hold the stem in the raised or normal position.

In the event of power failure, a spring return actuator returns the valve to its normal position. Non-spring return actuators will hold the last commanded position. See the Technical Instructions of the various actuators for additional information.

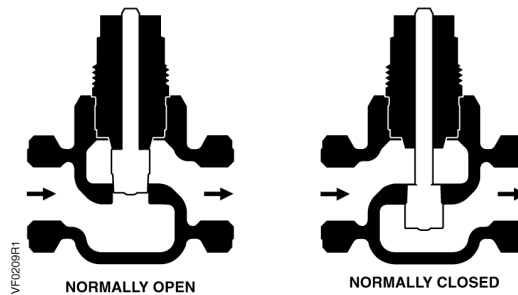

Figure 3.

Sizing

The sizing of a valve is important for correct system operation. An undersized valve will not have sufficient capacity at maximum load. An oversized valve can initiate cycling, and the seat and throttling plug can be damaged because of the restricted opening. Correct sizing of the control valve for actual expected conditions is considered essential for good control.

See Tables 3 through 6 for valve capacities.

Sizing, continued

The following variables must be determined:

- The medium to be controlled: water, etc.
- The maximum inlet temperature and pressure of the medium at the valve.
- The pressure differential that will exist across the valve under maximum load demand.
- The maximum capacity the valve must deliver.
- The maximum line pressure differential the valve actuator must close against.

See Application Bulletin (AB)-1 Control Valve Selection and Sizing (155-285) for further recommendations.

Mounting and Installation

Install the valve so that the flow follows the direction of the arrow indicated on the valve body.

For best performance, install the valve assembly with the actuator above the valve body. The valve and actuator can be installed in any position between vertical and horizontal. It is not recommended to install the valve assembly so that the actuator is below horizontal or upside-down.

Allow sufficient space for servicing the valve and actuator. See Table 11 for valve body dimensions. See Figure 4 and Table 10 for dimensions of the service envelope recommended around the actuator.

NOTE: Instructions for field mounting an actuator, wiring diagrams, and start-up are covered in the Technical Instructions and Installation Instructions for each actuator.

Service

Replace the valve if inoperable.

Disposal

Do not dispose of the valve as household waste.

- Special handling of individual components may be mandated by law or make ecological sense.
- Observe all local and currently applicable laws and regulations.



The actuators are considered electrical and electronic equipment for disposal in terms of the applicable European Directive and may not be disposed of as domestic garbage.

- Dispose of the actuators through channels provided for this purpose.
- Comply with all local and currently applicable laws and regulations.

Dimensions

The letters in Figure 4 refer to the valve centerline to top of actuator, the width of the actuator, and service envelope dimensions in Table 10. See Table 11 for valve body dimensions.

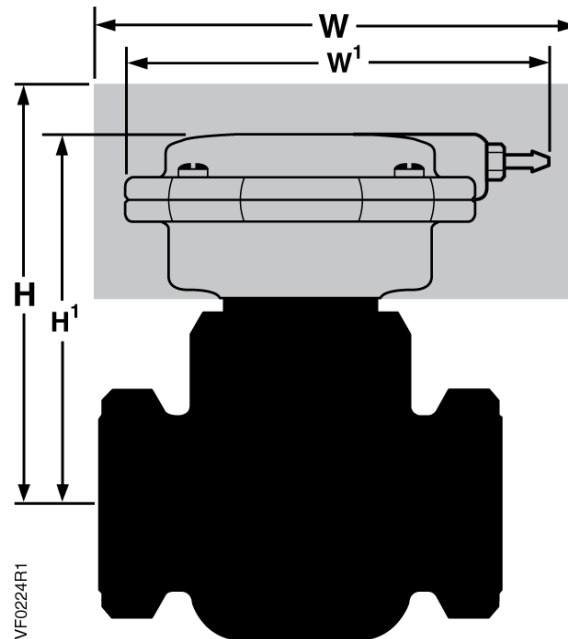
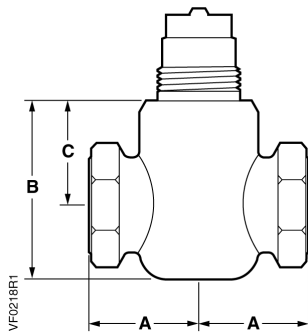

Figure 4.

Table 9. Actuator Dimensions and Recommended Service Envelope. Dimensions in Inches (Millimeters).

Actuator	Actuator Prefix Code	Valve Size	Center Line to Top of Actuator, H1	Service Height, H	Width or Diameter of Actuator, W1	Service Width W
599-01088 2-Inch Pneumatic	256 257 258	1/2 (15)	3-1/16 (78)	11 (280)	4 (100)	10 (250)
		3/4 (20)	3-1/16 (78)	11 (280)	4 (100)	10 (250)
		1 (25)	3-5/16 (84)	11-1/4 (285)	4 (100)	10 (250)
SAS NSR	363 364	1/2 (15)	7-1/2 (191)	15-1/2 (394)	3-1/2 (89)	7-1/2 (191)
		3/4 (20)	7-1/2 (191)	15-1/2 (394)	3-1/2 (89)	7-1/2 (191)
		1 (25)	7-3/4 (197)	15-3/4 (400)	3-1/2 (89)	7-1/2 (191)
SAS SR	365 366	1/2 (15)	7-1/2 (191)	15-1/2 (394)	4 (100)	8 (203)
		3/4 (20)	7-1/2 (191)	15-1/2 (394)	4 (100)	8 (203)
		1 (25)	7-3/4 (197)	15-3/4 (400)	4 (100)	8 (203)
SSC131_U SSC161_U	259 260 261 262	1/2 (15)	5 (127)	13 (330)	5-1/4 (133)	13-1/4 (337)
		3/4 (20)	5 (127)	13 (330)	5-1/4 (133)	13-1/4 (337)
		1 (25)	5-1/4 (133)	13-1/4 (337)	5-1/4 (133)	13-1/4 (337)



**Internal Thread NPT ×
 Internal Thread NPT
 IT×IT**

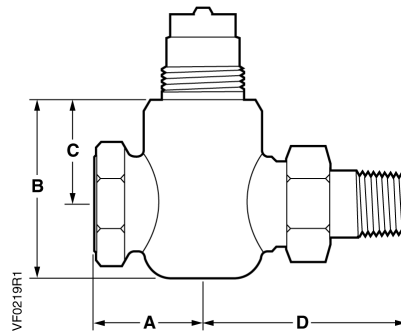

**Internal Thread NPT ×
 Union External Thread
 IT×UET**

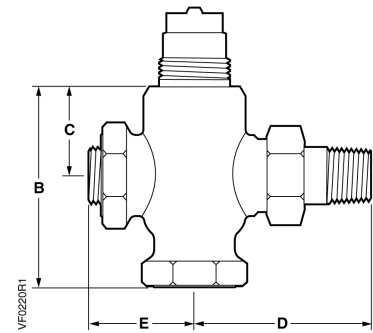

**Angle Internal Thread ×
 Union External Thread
 AIT×UMET**

Table 10. 2-way Valve Dimensions.

Valve Size inches	A	B		C	D	E	Weight lb (kg)		
		IT×IT & IT×UET	AIT×UMET				IT×IT	IT×UET	AIT×UMET
1/2 (15)	1-3/8 (35)	2-1/4 (57)	2-15/16 (74) NO Only	1-5/16 (33)	2-5/8 (67)	1-1/2 (38) NO only	0.96 (0.44)	1.14 (0.5)	1.4 (0.6)
3/4 (20)	1-5/8 (41)	2-3/8 (59)	—	1-5/16 (33)	3-1/8 (79)	—	1.13 (0.51)	1.45 (0.66)	—
1 (25)	1-15/16 (49)	2-3/4 (69)	—	1-9/16 (39)	—	—	1.7 (0.77)	—	—

Information in this publication is based on current specifications. The company reserves the right to make changes in specifications and models as design improvements are introduced. Product or company names mentioned herein may be the trademarks of their respective owners.
 © 2020-2025 Siemens Industry, Inc.