

RDX42.22U

Room Temperature Controller with LCD



Description	Controller for heat pump systems with reversing valve, optional electric heater, one- or two-stage heating and one-stage cooling.	
Features	<ul style="list-style-type: none"> • Outputs for one-stage compressor and reversing valve or on/off valve actuators • Output for auxiliary electric heating • Output for a one-speed fan • Room or return air temperature control • Manual heating/cooling changeover • Operating modes: Normal (heating, cooling), Energy Saving, Off • Operating mode changeover input for remote control • Selectable installation and control parameters • Operating voltage 24 Vac 	
Application	<ul style="list-style-type: none"> • For control of heat pump systems with reversing valve, optional electric heater, one- or two-stage heating and one-stage cooling • For control of room temperature in individual rooms that are heated or cooled with four-pipe fan coil units and optional electric heating • For opening and closing a valve • For switching a one-speed fan 	
Product Number	RDX42.22U	
Accessories	ARG70 QAH11.1 141-570	Adapter Plate for 4 x 4-inch conduit boxes Changeover/Remote Temperature Sensor Lockable Thermostat Guard
Ordering	The QAH11.1 temperature sensor (can also be used as a return air temperature sensor) and the zone valves must be ordered separately.	

Table 1 Equipment Combinations.

Product Number	Description	Technical Instructions
SFA/SFP Series	Zone valve actuators	155-321P25
599 Series Zone Valves	Zone valve bodies	155-320P25
GDE16...	44 lb-in NSR air damper actuators	155-187P25
GLB16...	88 lb-in NSR air damper actuators	155-187P25
Temperature Sensor	QAH11.1	155-329P25

Functions

The controller acquires the room temperature with its integrated sensor or via a return air temperature sensor (QAH11.1) and maintains the setpoint by delivering two-position control commands. The switching differential is 4°F (2°K) in heating mode (adjustable) and 2°F (1°K) in cooling mode (adjustable).

Fan Operation

Fan operation is selected on the controller's front panel, either in "Auto" or "Fan On" mode.

When function "(Auto) – temperature-dependent" is selected, the fan is switched on/off (one-speed) depending on the temperature and the control output. When function "Fan On" is selected, the fan will run continuously (one-speed).

The fan is switched off by:

- leaving the heating or cooling sequence, if the "Temperature-dependent fan control" function is activated.
- manually setting the "Heat-Off-Cool" selector to "Off".
- turning the controller's power supply off.

Fan overrun

When DIP switch 2 is set to OFF, the auxiliary heater is connected, the controller is in heating mode, and the fan overrun function is activated. When the electric heater output (terminal 7) is switched off by the controller in the heating sequence, the fan overrun will start based on the time delay set with parameter P08. Fan overrun has the highest priority and overrides the controller's Off position.

Heating Mode

The system will switch to Heating mode when the operating mode selector, on the front of the unit, is set to Heat.

On

The heating equipment receives the On command via control output terminal 10 when the following conditions are met:

1. The measured room temperature is half the switching differential below the setpoint, and
2. The heating output has been off for more than three minutes (adjustable).

The auxiliary heating equipment receives the On command via control output terminal 7 when these conditions exist:

1. Heating output terminal 10 is activated, and
 2. The measured room temperature is below the setpoint differential between heating and auxiliary heating (adjustable with parameter P12).
-

Off

The heating equipment receives the Off command via control output terminal 10 when the following conditions are met:

1. The measured room temperature is half the switching differential above the setpoint, and
2. The heating output has been on for more than one minute (adjustable, see *Parameters*).

The auxiliary heating equipment receives the off command via control output terminal 7 when:

1. The measured room temperature is above the setpoint differential between heating and auxiliary heating (W_D) (adjustable with parameters P12), and
 2. The auxiliary heating output has been on for more than one minute (adjustable, see *Parameters*).
-

Cooling Mode

When the operating mode selector is set to Cool, the system will switch to cooling mode.

On

The cooling equipment receives the On command via control output terminal 5 when the following conditions occur:

1. The measured room temperature is half the switching differential above the setpoint, and
 2. The cooling output has been off for more than three minutes (adjustable, see *Parameters*).
-

Off

The cooling equipment receives the Off command via control output terminal 5 when these conditions are met:

1. The measured room temperature is half the switching differential below the setpoint, and
 2. The cooling output has been on for more than one minute (adjustable, see *Parameters*).
-

Return air temperature

The RDX42.22U provides control based on room temperature or return air temperature. It detects if a QAH11.1 cable temperature sensor is connected to input terminals 9 and 8, and then operates automatically according to the return air temperature.

Operating Modes

The following operating modes are available:

Normal

Heating or cooling mode with selected fan operation (Auto or continuous on). In Normal operation, the controller maintains the adjusted setpoint. (See *Operation Diagram*).

Energy Saving

A changeover switch can be connected to status input D1-GND, located on the lower left side of the base plate, below the main terminal block. When the switch closes (due to an open window, for example), the operating mode will change from Normal operation to Energy Saving mode. In that case, the relevant setpoints of heating or cooling are maintained (setting of control parameters P01 and P02). The operating action of the switch (NC or NO) can be selected.

Off

When the operating mode selector is set to Off, the system will switch to Off mode. In this mode, the system does not activate any output. The display only shows the room temperature, or normal mode setpoint, according to the DIP switch setting table.

After a single press of the + or - button, the display shows the Normal mode setpoint. When the operating mode selector is set to Off, the system will stay in Off mode.

Operation Diagrams (Normal Mode)

NOTE: Changed "Actuator" to "Valve" in illustration.

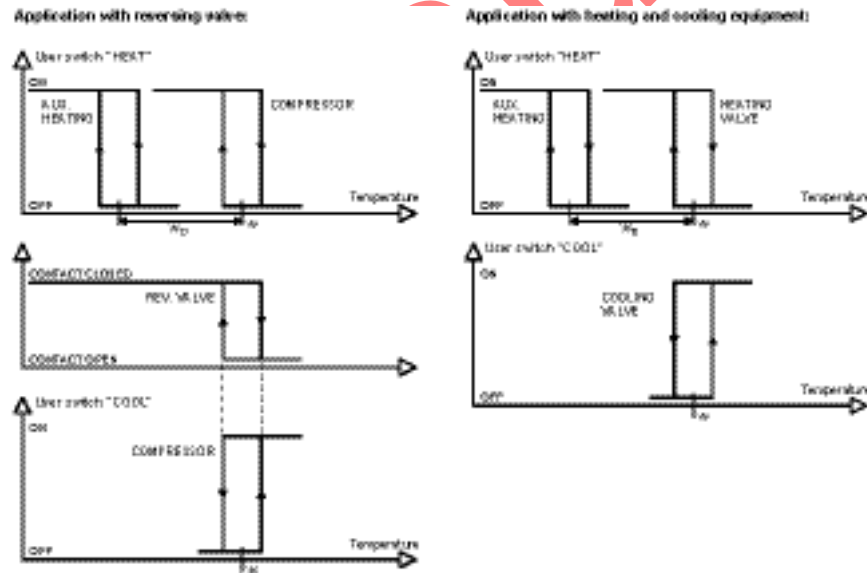

Figure 1. Operation Diagrams.

Mechanical Design

The unit consists of two parts:

- The plastic housing which accommodates the electronics, the operating elements and the built-in room temperature sensor, and
- The baseplate, which houses the wire terminations.

The housing engages in the baseplate and is secured with two screws.

The baseplate carries the screw terminals. The DIP switches are located at the rear of the housing.

**Setting and
 Operating Elements**

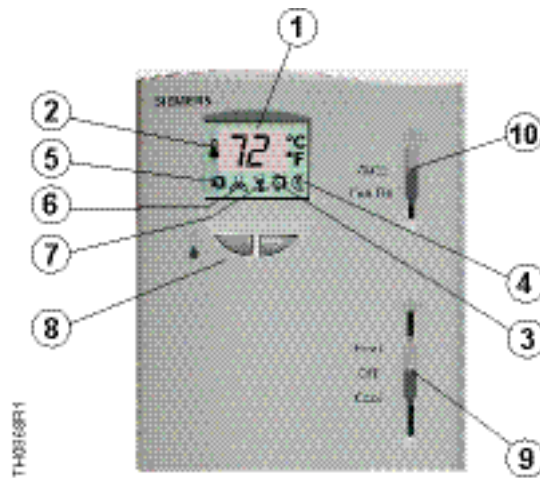

Figure 2.







1. Display of the room temperature (in degrees Fahrenheit or Celsius), setpoints or control parameters
2.  Symbol used when displaying the current room temperature
3.  Normal operation
4.  Energy Saving mode
5.  Cooling on
6.  Fan on
7.  Heating on
 Heating and auxiliary heating on
AUX
8. Buttons for adjusting the setpoints and setting the control parameters
9. Operating mode selector (Heat, Off, Cool)
10. Fan control
 (Auto: Controller switches fan on when heating or cooling output is active)
 (Fan On: Fan is constantly running)

Table 2. DIP Switch Table.

DIP Switch	Function	Position OFF	Position ON
1	Operating action of remote ON/OFF switch	Changeover activated when switch is open (NC)	Changeover activated when switch is closed (NO) *
2	Auxiliary heating function	Auxiliary heater connected	No auxiliary heater connected *
3	Temperature/setpoint display	Temperature setpoint	Room temperature *
4	Temperature display	Degrees Fahrenheit *	Degrees Celsius

* Factory setting

Setting the Control Parameters

A number of control parameters can be set to optimize the control performance. These parameters can also be set during operation without opening the unit. In the event of power failure, all control parameter settings set will be maintained.

Settings

The parameters can be changed as follows;

1. Press the + and - buttons simultaneously for three seconds. Release them and, within two seconds, press the + button again for three seconds. Then, the display will show "P01".
2. Select the required parameter by repeatedly pressing the + and - buttons:

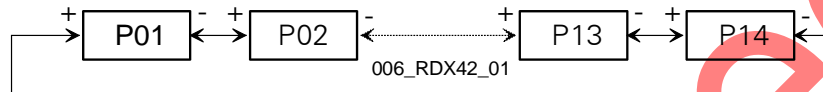

3. By pressing the + and - buttons simultaneously, the current value of the selected parameter appears, which can be changed by repeatedly pressing the + and - buttons. To exit from the individual parameter setting mode, press the + and - buttons simultaneously again and the parameter mode setting number will be displayed "Pxx". You can now choose another parameter mode number setting.
4. By pressing the + and - buttons simultaneously again, or five seconds after the last press of a button, the last parameter will be displayed again.
5. If you wish to display and change additional parameters, repeat steps 2 through 4.
6. Wait 10 seconds after the last display or setting, all changes are stored and the controller returns to Normal mode.

P13 and P14 (Display only, no setting)

P13 shows the room temperature and the sensor being used by the device to calculate the output.

P14 displays the current value of the temperature sensor connected.

- 1: Internal sensor
- 2: External sensor. No settings

If the position of the operating mode selector or remote ON/OFF switch is changed in this parameter setting mode, the device will abort the setting mode and respond to the new input after 10 seconds. The data changes are saved.

Table 3. Control Parameters.

Parameter	Meaning	Setting Range	Factory Setting
P01	Heating setpoint in Energy Saving mode (operating mode changeover switch activated)	OFF, 46°F to 64.5°F (8°C to 18°C) (in increments of 1°F)	61°F (16°C)
P02	Cooling setpoint in Energy Saving mode (operating mode changeover switch activated)	OFF, 75°F to 95°F (24°C to 35°C) (in increments of 1°F)	82.5°F (28°C)
P03	Minimum setpoint in Normal mode	46°F to 68°F (8°C to 20°C) (in increments of 2°F)	46°F (8°C)
P04	Maximum setpoint in Normal mode	70°F to 95°F (21°C to 35°C) (in increments of 2°F)	95°F (35°C)
P05	Minimum compressor off-time	1 to 10 minutes (in increments of 1 min)	3 min
P06	Minimum compressor on-time	1 to 10 minutes (in increments of 1 min)	1 min
P07	Auxiliary heater minimum hold time	1 to 10 minutes (in increments of 1 min)	1 min
P08	Fan overrun after auxiliary heater off	30 to 300 seconds (in increments of 10 seconds)	30 s.
P09	Sensor calibration	-3 to 3 K (in increments of 0.5 K) (0.5 K = °F)	0 K
P10	Switching differential in heating mode	0.5 to 4 K (in increments of 0.5 K) (0.5 K = °F)	2 K
P11	Switching differential in cooling mode	0.5 to 4 K (in increments of 0.5 K) (0.5 K = °F)	1 K
P12	Setpoint differential between heating and auxiliary heating W_D	0.5 to 5 K (in increments of 0.5 K) (0.5 K = °F)	2 K
P13	Value of current room temperature	No setting, display only	—
P14	Active temperature sensor (display only, no setting choices)	1: Room temperature sensor active 2: Return temperature sensor active	—

Mounting, Installation and Commissioning Notes

- Check the position of the DIP switches and change them, if necessary.
- After applying power, the controller makes a reset, which takes approximately three seconds; it is then ready to operate.
- Mount the unit on a wall of the room to be heated or cooled. Do not mount in direct sunlight or near other heat or refrigeration sources. (See Figure 3.)
- Mounting height is approximately 60 inches (150 cm) above the floor. (See Figure 3.)
- The connecting wires can be run to the controller from a recessed conduit box.

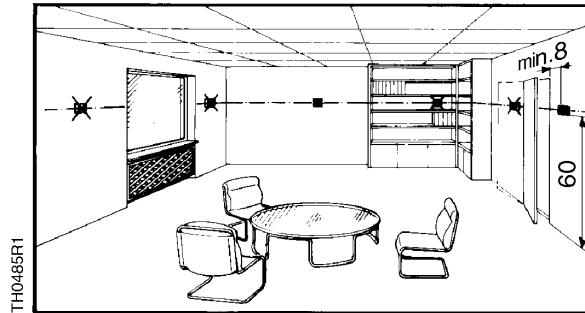

Figure 3. Acceptable Mounting Locations.

- The cables used must satisfy the insulation requirements for 24 Vac potential.
- To access the wire terminal block, loosen the cover screw and open the plastic cover. See Figure 4.

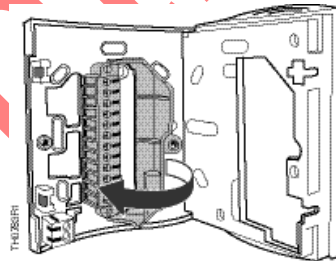

Figure 4. Accessing the Wire Terminal Block.

- Sensor inputs 9-8 carry 24 Vac potential. If the sensor's cables must be extended, they must be suited for 24 Vac voltage.
- Complete installation instructions are included with the controller.

Calibrating the Sensor

If the room temperature displayed by the controller is inconsistent with the room temperature effectively measured, the temperature sensor can be recalibrated. In that case, parameter P09 must be changed.

Specifications Power Supply	Operating voltage	24 Vac \pm 20%	
	Frequency	50/60 Hz	
	Power consumption	Maximum 6 VA	
	Control output FAN Rating	24 Vac Maximum 5(3)A	
	Control outputs COOLING and HEATING Rating	24 Vac Maximum 5(3)A	
	Control output AUX. HEATING Rating	24 Vac Maximum 5(3)A	
		Remote temperature sensor status input 8-7	QAH11.1 safety class II NTC resistor 3 k ohm at 77°F (25°C)
	Status input D1 and GND Operating action selectable Contact sensing Insulation against line voltage	Normal open (NO) Normal closed (NC) SELV 6 to 15 Vdc/3 to 6 mA, 4kV reinforced insulation	
	Permissible cable length with copper cable 2 x 16 AWG or 1 x 14 AWG for connection to terminals 8 and D1	262 ft (80 m)	
Operational data	Setpoint setting range	46°F to 95°F (8°C to 35°C)	
	Control deviation at 77°F (25°C)	Maximum \pm 1°F (0.5 K)	
		Setting Range	Factory Setting
	Switching differential in heating mode (adj)	1°F to 7°F	3.5°F (2 K)
	Switching differential in cooling mode (adj)	1°F to 7°F	2°F (1 K)
	Setpoint differential W_D (adjustable)	1°F to 9°F	3.5°F (2 K)
	Setpoint (Energy Saving Mode C), heating	46°F to 64°F	61°(16°C)
Setpoint (Energy Saving Mode C), cooling	75°F to 95°F	82.5°F (28°C)	
Environmental Conditions	Operation Temperature	32°F to 122°F (0°C to 50°C)	
	Humidity	<95% rh	
	Shipping and storage Temperature	-13°F to 158°F (-25°C to 70°C)	
	Humidity	<95% rh	
Agency Approvals		Conforms to CE requirements NEMA 1	
General	Connection terminals	Use solid wires or prepared stranded wires. 22 AWG to 14 AWG	
	Weight	0.5 lb (0.225 kg)	
	Housing cover color	White	

Wiring Terminals

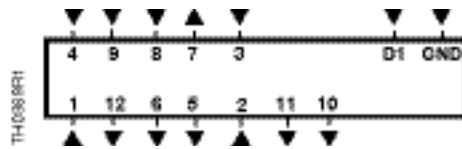

Figure 5. Wiring.

- 1,2,3 Operating voltage, 24 Vac Neg
- 4 Operating voltage, 24 Vac Pos
- 5 Cooling output, NO contact
- 6 Cooling output, NC contact
- 7 Auxiliary heating output
- 8 Measuring neutral remote sensor
- 9 Remote temperature sensor (QAH11.1)
- 10 Heating output, NO contact
- 11 Heating output, NC contact
- 12 Fan output at single speed
- D1, GND Signal input for potential-free operating mode changeover

Wiring Diagrams

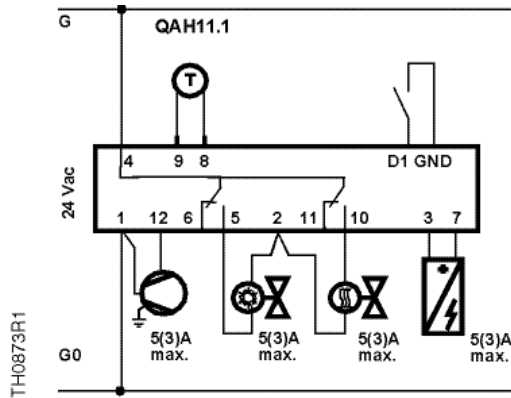

Figure 6. Four-pipe System Wiring.

- 6 Cooling output NC contact
- 5 Cooling output NO contact
- 11 Heating output NC contact
- 10 Heating output NO contact

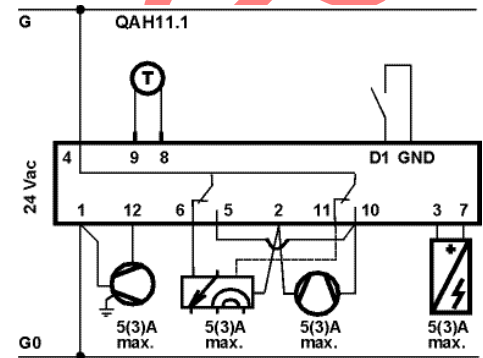

Figure 7. Heat Pump Wiring.

- 6 Cooling output NC contact for reversing valve
- 5 Cooling output NO contact for compressor
- 11 Heating output NC contact for reversing valve
- 10 Heating output NO contact for compressor

NOTE: Outputs 5 and 10 must be wired together for compressor control

Dimensions

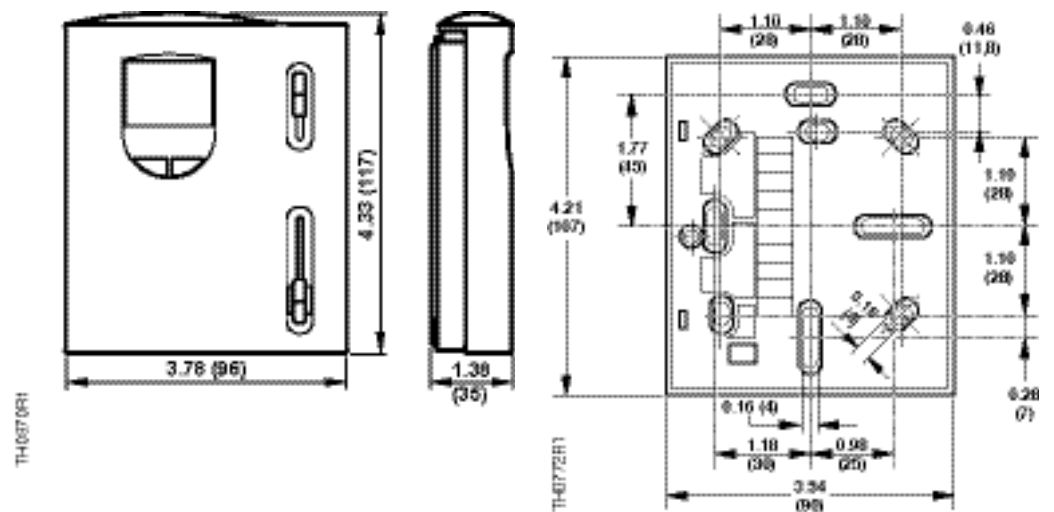

Figure 8. RDX42.22U Dimensions in Inches (mm).

Information in this publication is based on current specifications. The company reserves the right to make changes in specifications and models as design improvements are introduced. Product or company names mentioned herein may be the trademarks of their respective owners.
© 2008 Siemens Industry, Inc.