

VAV with Reheat (HW or Electric)

## **Features**

- Configurable flow sensor range to match QVM sensor.
- Dynamic minimum airflow input allows demand controlled ventilation.
- PID control minimizes offset and maintains tighter set point control.
- Standby mode enables energy savings during occupied hours for rooms that are not always used. When occupants are sensed, the controller quickly responds to maintain comfort levels.
- Diversity control, through a demand limit input, maximizes comfort by maintaining even air distribution to all zones during morning warm-up or pre-cool operation.

## **Sequence of Operation**

In this core configuration, the Predator operates perimeter heat, the reheat coil and the primary air damper to maintain required room temperature and ventilation conditions.

### **Occupied Mode**

The Predator applies occupied settings for the space temperature setpoints and the primary airflow minimum. The typical result is continuous ventilation, with heating or cooling automatically selected to maintain comfort.

### **Cooling**

The cooling PID maintains the measured space temperature at the occupied cooling setpoint by modulating the primary airflow setpoint between the maximum cooling flow and the minimum cooling flow.

The active minimum airflow may be dynamically adjusted over the network according to air quality considerations.

The primary airflow PID maintains the measured airflow at the varying setpoint by modulating the position of the primary air damper.

The reheat coil is off.

Perimeter heat is off.

Lighting is on.

## ***Heating***

The heating PID maintains the measured space temperature at the occupied heating setpoint by modulating perimeter heat, the reheat coil and the primary airflow setpoint. The setpoint varies between the maximum heating flow and the minimum heating flow. Relative sequencing of perimeter heat, the reheat coil and the primary airflow is set according to site-specific requirements.

Lighting is on.

## **Unoccupied Mode**

The Predator applies unoccupied settings for the space temperature setpoints and the primary airflow minimum. The typical result is a wide operating band with no HVAC energy consumption, and heating or cooling applied only at extreme conditions.

## ***Cooling***

The cooling PID maintains the measured space temperature at the unoccupied cooling setpoint by modulating the primary airflow setpoint between the maximum cooling flow and the unoccupied minimum flow.

The primary airflow PID maintains the measured airflow at the varying setpoint by modulating the position of the primary air damper.

The reheat coil is off.

Perimeter heat is off.

Lighting is off.

## ***Heating***

The heating PID maintains the measured space temperature at the unoccupied heating setpoint. Operation of each HVAC device, in response to heating demand is selectable in the unoccupied mode. The behavior of primary air damper and reheat coil may be individually configured. They may be locked out, modulated or cycled according to the required sequence.

Lighting is off.

## **Bypass Mode**

During unoccupied periods, an occupant can put the Predator in the bypass mode by pressing the bypass button on the room temperature sensor. This causes the controller to operate exactly as in the occupied mode, for an adjustable amount of time.

## **Standby Mode**

Standby mode applies separately adjustable temperature and ventilation setpoints. These may be adjusted to conserve energy, but allow quicker recovery compared to the unoccupied mode. Otherwise, operation is the same as the unoccupied mode.

## **Morning Warmup**

During unoccupied periods, if the Predator is commanded to warmup mode, it applies the occupied heating setpoint (to restore comfort conditions) and the unoccupied minimum flow (because occupants are not present). Operation of each HVAC device, in response to heating demand is selectable in the warmup mode. The behavior of perimeter heat, the primary air damper and the reheat coil may be individually configured. They may be forced on, locked out, modulated or cycled according to the required sequence.

Lighting is off.

## Pre-cool

During unoccupied periods, if the Predator is commanded to pre-cool mode, it applies the occupied cooling setpoint (to restore comfort conditions) and the unoccupied minimum flow (because the occupants are not present).

The reheat coil is off.

Perimeter heat is off.

Lighting is off.

## Calibrate (Test)

Recalibration will occur in test mode when RecalExtEn is set to TRUE. Once commanded to test mode, the controller remains in this mode (even if it is commanded to another mode) until the recalibration is complete. This process takes approximately two times the damper motor travel time. The Predator closes the primary air damper and calibrates the airflow sensor.

The reheat coil is off.

If perimeter heat is active, it continues to operate.

Lighting is on or off according to occupancy.

## Off

The Predator closes the primary air damper, and turns off the reheat coil, and turns off perimeter heat.

Lighting is off.

# Occupancy Control

## Occupancy Mode

The Predator controller defaults to the occupied mode of operation. Upon receipt of the 4-state LonMark occupancy override (*nviOccManCmd*), the controller will switch to the appropriate mode of operation. A brief summary of each mode follows below:

<u>LonMark</u>		
<u>Occupancy State</u>	<u>Mode</u>	<u>Description</u>
(0)	Occupied	Controller in Occupied mode and uses Occupied setpoints.
(1)	Unoccupied	Controller in Unoccupied mode and uses Unoccupied setpoints.
(2)	Bypass	Controller temporarily in Occupied mode and uses Occupied setpoints until the Bypass Time elapses. Controller then returns to previous occupancy state.
(3)	Standby	Controller in Standby mode and uses Standby setpoints.

If a LonMark compatible occupancy schedule input (*nviOccSchedule*) is used, the controller will use the modes and setpoints as shown above. This will allow the Predator controller to utilize the scheduling properties of other devices on the LonTalk Network.

The occupancy signal could also come from a time clock, wall switch, or occupancy sensor physically wired to one of the inputs of the Predator controller. This occupancy signal could then be shared with other controllers via the Lon Network.

## **Bypass Mode**

If enabled (through *stptDialEn*) and the Bypass button on the Predator room sensor is pressed, the controller will be placed in the Bypass mode for the amount of time specified by the controller's configuration parameters (default 60 min. – see Table 2). If the button is subsequently pressed again prior to the expiration of the Bypass time, the timer will reset to the initial value and resume counting down.

## **Priorities of Occupancy Control**

Occupancy overrides are prioritized as follows (listed from highest to lowest):

- Operator Command – A valid occupied command sent from system operator.
- Bypass Button – Button on Talon room sensor, also utilized by occupants of room.
- Occupancy Sensor/Wall Switch – Locally connected or signal via the network.
- Occupancy Schedule – Sent from network.

## **Optional Functions**

### **Room Temperature Sensor Sharing**

The Predator Room Temperature Sensor may share its value with other controllers on the LonTalk network via a network binding. This is most commonly done when multiple terminal units serve a room or area.

### **Duct Temperature Sensor**

An optional duct temperature sensor may be connected to the Predator controller for the purpose of monitoring the source temperature. This is useful for functions such as morning warmup, when you want to be sure warm air is being provided to the box, or as an aid in troubleshooting space comfort problems.

### **Occupancy Sensor/Wall Switch**

An optional maintained contact wall switch may be used to control the occupancy mode of a room. Rooms with variable occupancy (conference rooms, etc.) can use this device to control occupancy and the lights with one switch.

Another useful option is to utilize an occupancy sensor to control the occupancy mode of the Predator controller. The function of this device would be similar to the wall switch above, but an occupant entering the room would not perform any manual action to put the room into occupied mode. If the schedule is in the occupied mode and the occupancy sensor does not detect people in the room, the room will go into the standby mode enabling energy savings while maintaining occupant comfort.

### **Lighting Control Relay**

The Predator controller can selectively operate with maintained contacts or pulsed contacts to switch lighting control relays. This is useful in those instances where lighting control is desired, but a lighting control panel with a LonTalk interface is either not present or not feasible.

### **Analog Damper Actuator**

The standard application is setup to use a Siemens GDE or GLB, or similar 3-point floating actuator for air volume control. Alternatively, A Siemens Open Air™ or similar damper actuator could be utilized if 0-10 VDC modulating control is desired.

## Perimeter Heat

This application also supports the optional control of perimeter heat. The algorithm supports analog, 3-point floating, pulse width modulation, and on/off control of the perimeter heat. Perimeter heat operates independently of terminal airflow or the current state of the terminal fan.

## Flow Sensor Range

This application has been designed to use the Siemens QVM variable range flow sensor, (P/N: QVM62.1). The flow sensor has a range of 5, 10, 15 m/s and is jumper adjusted. The controller should be configured with the same range. The default setting for the sensor and controller is 10 m/s.

## Hardware Map – VAV/CV

### Sample Hardware Map for the VAV with Reheat (HW or Elec) Application Configuration

Configuration Property	Element	Input/Output Type	Factory Hardware Setting (VAV/CV)	Desired Setting Settings that <b>need to be changed</b> from the factory defaults are shown in <b>BOLD</b> face type.
inStat	statTempOffset	-	0°F 0°C	0°F 0°C
	statSetptOffset	-	0°F 0°C	0°F 0°C
Inputs	statTemp	TEMP	SPACE_TEMP	SPACE_TEMP
	statSetpt	TEMP	SPACE_SETPT_TEMP	SPACE_SETPT_TEMP
	statOvrdd	DI	STAT_SWITCH_DI	STAT_SWITCH_DI
	IN1	DI, TEMP	SPARE2_IN	<b>IN_UNUSED</b>
	IN2	DI, TEMP	SOURCE_TEMP	<b>IN_UNUSED</b>
	IN3	DI, PCT, TEMP	OCC_SENSOR_DI	<b>IN_UNUSED</b>
	IN4	DI, PCT, TEMP	SPARE3_IN	<b>IN_UNUSED</b>
	IN5	DI, PCT, TEMP	SPARE1_IN	<b>IN_UNUSED</b>
outputs	IN6	DI, PCT, TEMP	VELOCITY_EXT1_PCT	VELOCITY_EXT1_PCT
	OUTA1	AO	FLOW_DMPR_AO	<b>OUT_UNUSED</b>
	OUTA2	AO	TRM_H_COIL_AO	<b>OUT_UNUSED</b>
	OUTA3	AO	SPARE2_OUT	<b>OUT_UNUSED</b>
	OUTD1	DO, FLT_MTR	FLOW_DMPR_FLT_MTR	FLOW_DMPR_FLT_MTR
	OUTD2	DO, FLT_MTR	FLOW_DMPR_FLT_MTR	FLOW_DMPR_FLT_MTR
	OUTD3	DO, FLT_MTR	TRM_H_COIL_FLT_MTR	TRM_H_COIL_FLT_MTR
	OUTD4	DO, FLT_MTR	TRM_H_COIL_FLT_MTR	TRM_H_COIL_FLT_MTR
	OUTD5	DO, FLT_MTR	TRM_FAN_DO	<b>OUT_UNUSED</b>
	OUTD6	DO, FLT_MTR	PERIM_H_COIL_FLT_MTR	<b>OUT_UNUSED</b>
	OUTD7	DO, FLT_MTR	PERIM_H_COIL_FLT_MTR	<b>OUT_UNUSED</b>
OUTD8	DO, FLT_MTR	SPARE1_OUT	<b>OUT_UNUSED</b>	

# Sample Wiring Diagram for VAV with Reheat (HW or Elec) Application Configuration

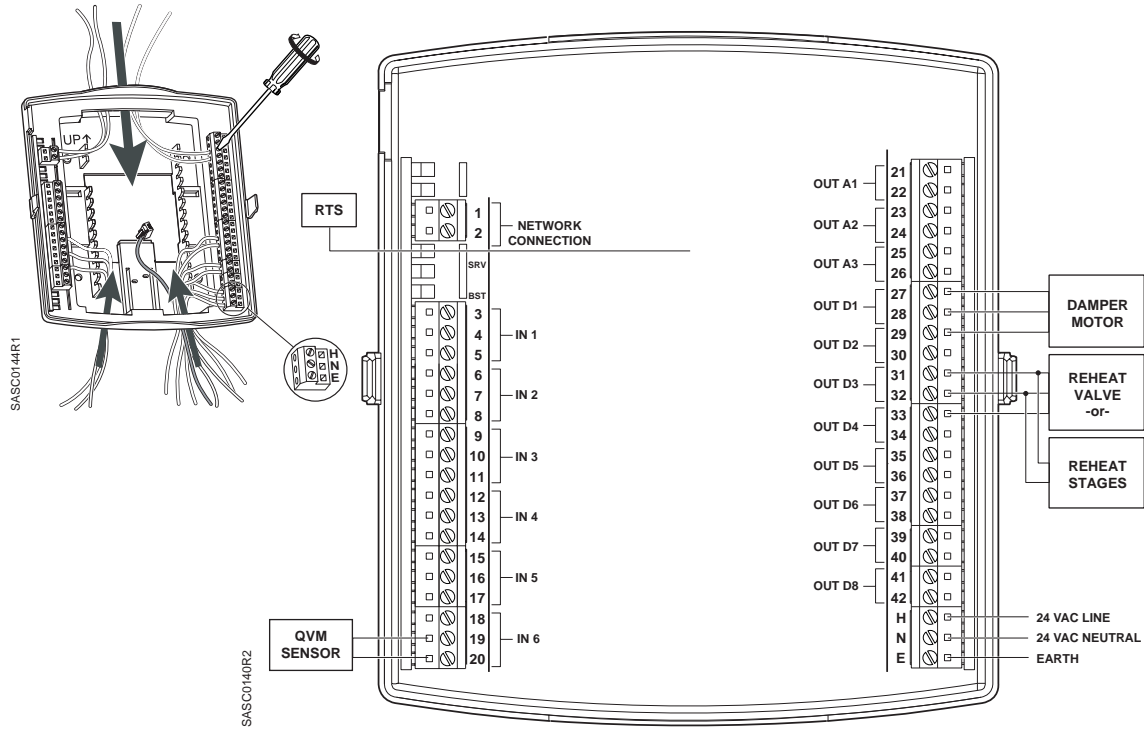

Note: Route wiring from either the bottom opening when using a J-box or from the base sides as shown in the picture when flat or din rail mounting. The image above is for illustrative purposes only

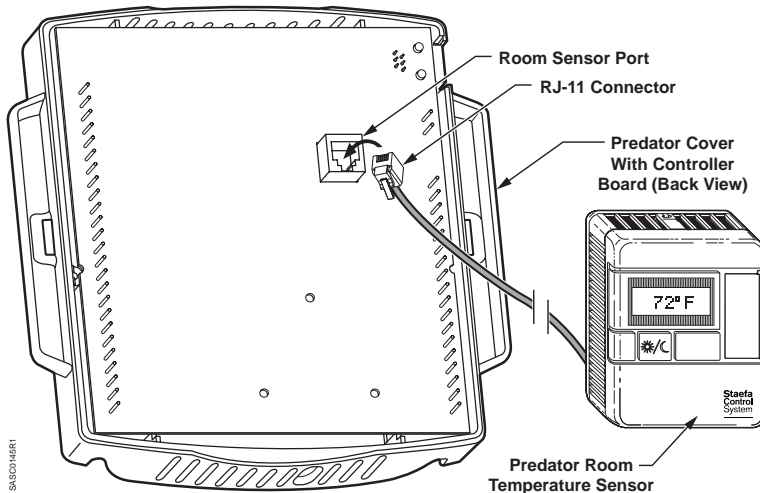

## Wiring Recommendations:

IN and AO: 20 to 22 AWG  
 DO: 18 to 22 AWG  
 Power: 16 to 18 AWG  
 LON Network: 22 AWG Level 4

## Transformer Requirements:

Type: Class 2, 24 VAC, 50/60Hz

Predator Wiring Diagrams (Full Point Board Shown).

# Ideal Material Solution

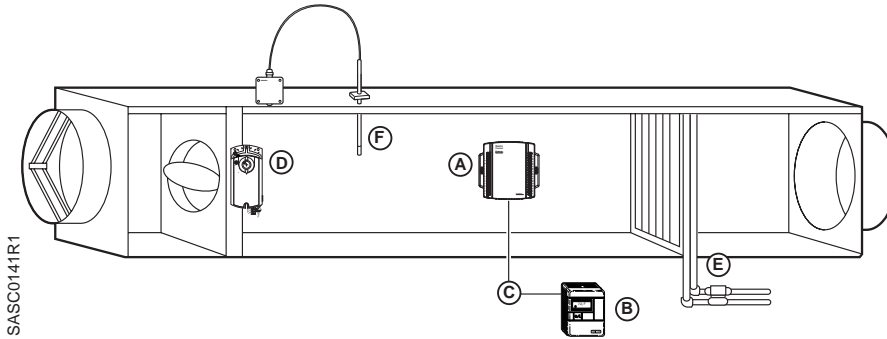

Tag	Description	Product #
A	Predator 10K SD VAV/CV 6IN, 8DO, 3AO	588-526
	Predator Full Point Wiring Base	587-175
B	Predator Room Sensors:	
	Sensing Only	587-180
	Override	587-181
	Setpoint	587-182
	Temperature Display**	587-183
	Setpoint and Override	587-184
	Override and Temperature Display**	587-185
	Setpoint and Temperature Display**	587-186
	Setpoint and Temperature Display**	587-187
	With terminal blocks and warmer/cooler setpoint adjustment	587-188
	With terminal blocks, warmer/cooler setpoint adjustment and occupancy override	587-189
	With terminal blocks, warmer/cooler setpoint adjustment, occupancy override and LCD display	587-196
	Predator Room Sensors without Logos	
	<b>No Logo</b> Sensing Only	587-550B
	<b>No Logo</b> Setpoint	587-552B
<b>No Logo</b> Setpoint and Override	587-554B	
<b>No Logo</b> Setpoint, Override and Temperature Display	587-557B	
Mylar Tabs – 20 pack (covers RJ-11 opening for 4 conductor cables)	544-634P20	
Flush Mount 10K Room Sensor	536-994B	
C	Predator Room Sensor RJ-11 Pre-terminated 6 Conductor Plenum Rated Cables	
	25 Foot	588-100A
	50 Foot	588-100B
	100 Foot	588-100C
	Predator RS RJ-11 Pre-terminated 4-Conductor (no network connection) Plenum Rated Cables	
	25 Foot	588-101A
	50 Foot	588-101B
100 Foot	588-101C	
D	Floating Damper Actuator 44 lb. in.	GDE131.1P
E	Analog 24V Valve Actuators	
	Powermite (5.5mm stroke)	SSB81U
	Zone (2.5mm stroke)	
	3 position, fail in place, NC	SSA81
3 position, fail in place, NC	SFA71U	
on/off, fail safe, NC	SFP71U	
on/off, fail safe, NO		
F	Air Velocity Sensor	QVM62.1
Not shown	Outside Air Temperature 10K Thermistor -40 to 120°F	587-692

\*\* Sensors will display Fahrenheit or Celsius

## Configuration Table

The following table lists all of the configuration properties (CPs) available with this application. For more information on how to set these properties for a CV with Reheat configuration, please consult the *Predator VAV/CV Application Guide*.

### Configuration Properties - VAV/CV

Configuration Property	Element	Factory Value
actDisplay		command
airTermType		no_Fan
bypassTime		60 minutes
clgDmdCtrB		
	Pb	1.8°C 53.2°F)
	Ti	300.0 seconds
	Td	0.0 seconds
ductArea		1.0764 ft2 (0.1000 m2)
dynMinScope		off
fanUnocccHtg		modulate
fanWarmup		on
flowDmprMotr		
	TravelTime	90.0 sec
	Reverse	False
	SyncDirection	close
flowDmprSat		
	SaturationLoad	110%
	PrctDeadband	2%
	TimeDelay	10 min
flowFanRq		
	PercentOn	110.00%
	PercentOff	100.00%
flowUnocccHtg		modulate
flowVav		
	Enable	TRUE
	DmdAtMin	0.00%
	DmdAtMax	100.00%
flowWarmup		off
hCoilFanRq		
	PercentOn	3.00%
	PercentOff	0.00%
hCoilUnoccc		Cycle
hCoilWrmup		Cycle
hStageCyc		10 minutes
htgClgSwit		
	DmdDeadband	5.00%
	TmpDeadband	0.0°C (0.0°F)

Configuration Property	Element	Factory Value
	TimeDelay	0.0 minutes
htgDmdCtrB		
	Pb	1.8°C (3.2°F)
	Ti	300.0 seconds
	Td	0.0 seconds
htgDmdFanRq		
	PercentOn	110.00%
	PercentOff	100.00%
htgFanDelay		2 minutes
htgSwitMeth		deadBand
lightsLag		10 minutes
maxFlow		4721 l/s (1000 CFM)
maxFlowHotPri		1180 l/s (2500 CFM)
maxFlowHeat		236 l/s (500 CFM)
minFlow		94 l/s (200 CFM)
minFlowHeat		94 l/s (200 CFM)
minFlowStby		94 l/s (200 CFM)
minFlowUnoc		0 l/s (0 CFM)
numHStages		0
numPerimStgs		0
occSensPrior		Unoccupied
occSensorEn		False
perimHUnocc		modulate
perimHWrmup		Cycle
perimHeatSat		
	SaturationLoad	110%
	TempDeadband	2°C (3.6°F)
	TimeDelay	10 min
perimHtgCoil		
	Enable	False
	DmdAtMin	0.00%
	DmdAtMax	100.00%
perimHtgMotr		
	TravelTime	125 seconds
	Reverse	False
	SyncDirection	Close
RecalExtEn		False
sensConstVAV		0.63
seriesStDelay		0.0 seconds
sourceTempLim		
	NeededToCool	18.0°C (64.4°F)

Configuration Property	Element	Factory Value
	NeededToHeat	25.0°C (77.0°F)
statSwitchEn		False
stptDialEn		False
stptOffstSpan		2.0 deg C
tempStptLim		
	MinTemp	19.0°C (66.2°F)
	MaxTemp	25.0°C (77.0°F)
trmFlowCtrB		
	Pb	4°C (7.2°F)
	Ti	12.0 seconds
	Td	0.0 seconds
trmFlowSat		
	SaturationLoad	110%
	TempDeadband	2°C (3.6°F)
	TimeDelay	10 min
trmHeatSat		
	SaturationLoad	110%
	TempDeadband	2°C (3.6°F)
	TimeDelay	10 min
trmHtgCoil		
	Enable	False
	DmdAtMin	0.00%
	DmdAtMax	100.00%
trmHtgEnrgy		Hot Water
trmHtgMotr		
	TravelTime	125.0 seconds
	Reverse	False
	SyncDirection	close
VelRangeExt1		10 m/s

\* Available on some models of the Predator Room Temperature Sensor.

### Network Configuration Inputs (nci) - VAV/CV

NV Name	Element	Factory Value
nciPrOffset		0.00%
nciSetPnts		
	Occupied Cooling Setpoint	73.4°F (23.0°C)
	Standby Cooling Setpoint	77.0°F (25.0°C)
	Unoccupied Cooling Setpoint	82.4°F (28.0°C)
	Occupied Heating Setpoint	69.8°F (21.0°C)
	Standby Heating Setpoint	66.2°F (19.0°C)
	Unoccupied Heating Setpoint	60.8°F (16.0°C)

## Control Mode Interaction Table – VAV/CV

	Heat		Warmup	Cool		PreCool Unocc	Off	Test (Calibrate)	Emerg Heat Unocc	Fan Only
	Occ	Unocc	Unocc	Occ	Unocc					
<b>Term Htg Coil</b>	Heat Loop	Heat Loop Cycle Off Max	Heat Loop Cycle Off Max	Closed	Closed	Closed	Closed		Heat Loop	Closed
<b>Perim Heat</b>	Heat Loop	Heat Loop Cycle Off Max	Heat Loop Cycle Off Max	Closed	Closed	Closed	Closed	Heat Loop	Heat Loop	Closed
<b>Flow Dmpr</b>	Heat Loop	Heat Loop Cycle Off Max	Heat Loop Max Min	Cool Loop	Cool Loop	Cool Loop	Closed	Closed	Heat Loop	Closed
<b>Series Fan</b>	ON	Demand	Demand	ON	Demand	Demand	OFF	OFF	Demand	ON
<b>Parallel Fan</b>	Demand	Demand	Demand	Demand	OFF	OFF	OFF	OFF	Demand	ON
<b>Flow Limits</b>	Htg Max Htg Min	Htg Max Unocc Min	Htg Max Unocc Min	Clg Max Clg Min	Clg Max Unocc Min	Clg Max Unocc Min	No Flow	No Flow	Max Min	No Flow
<b>Temp Stpt</b>	Occ Heat	Unocc Heat	Occ Heat	Occ Cool	Unocc Cool	Occ Cool	N/A	N/A	Unocc	N/A

**Color Key:** Red = OFF (not used); Green = Active (fixed in application); Yellow = Selectable (configurable)

**Notice:** Information in this document is based on specifications believed correct at the time of publication. The right is reserved to make changes as design improvements are introduced.

**Credits:** *Raptor*, *Predator*, and *TALON* are trademarks of Siemens Building Technologies, Inc. *Niagara Framework* is a registered trademark of Tridium, Inc. Other products and company names herein may be the trademarks of their respective owners.

# TALON

Siemens Building Technologies, Inc.  
 HVAC Products  
 1000 Deerfield Parkway  
 Buffalo Grove, Illinois 60089  
 Phone 847-215-1000  
[SBT\\_technical.editor.us.sbt@siemens.com](mailto:SBT_technical.editor.us.sbt@siemens.com)



LONMARK  
SPONSOR

Copyright 2008 by Siemens Building Technologies, Inc.