

SQV Series Electromotoric Valve Actuators

(For use with 2-1/2 to 8-inch Pressure Independent Control Valves)

Product Description

The SQV spring return (fail-safe) actuator requires a 24-volt power supply and a 0 to 10 Vdc or floating control signal to control the Pressure Independent Control series valve with 20 to 43 mm stroke.

Product Numbers



SQV91P30U Normally Open

SQV91P40U Normally Closed

Contents

- SQV Actuator
- Conduit Adapter
- Stroke Indicators (2)
- Anti-rotation Device

Warning/Caution Notations

WARNING:		Personal injury or loss of life may occur if you do not follow the procedures as specified.
CAUTION:		Equipment damage or loss of data may occur if you do not follow the procedures as specified.

Troubleshooting

- Check the wiring for the proper connections.
- If actuator becomes inoperable, replace the unit.

Required Tools

- 6 mm hex key
- 3/16" flat-blade screwdriver or T15 Torx driver (to remove wiring compartment cover)
- Small, flat-blade screwdriver (for wiring terminal block)

Expected Installation Time

20 to 30 minutes

Prerequisites

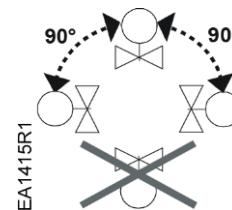

Figure 1. Acceptable Mounting Positions.

NOTE: This device complies with part 15 of the FCC Rules. Operation is subject to the following two conditions: (1) This device may not cause harmful interference, and (2) this device must accept any interference received, including interference that may cause undesired operation.

NOTE: This equipment is intended to be supplied by a Class 2 power source. All control signals and output are Class 2 AC/DC.

Allowed wire size: 16 to 20 AWG

Installation

1. Using a 6 mm hex wrench, loosen the two hex head cap screws on the bonnet connection. See Figure 2.

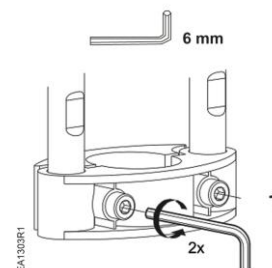

Figure 2. Hex Head Cap Screws.

Installation, Continued

NOTE: Only loosen the screws until flush with brackets; do not remove. See Figure 3.

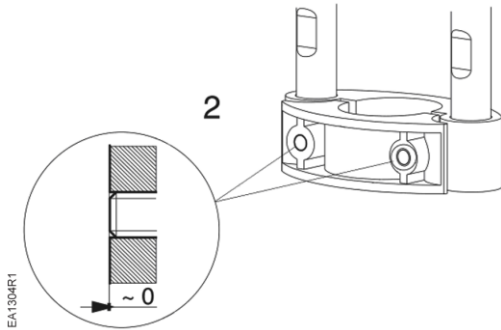

Figure 3.

2. Push up on the actuator's valve stem connection until it locks into place, opening it to accept the valve stem. See Figure 4.

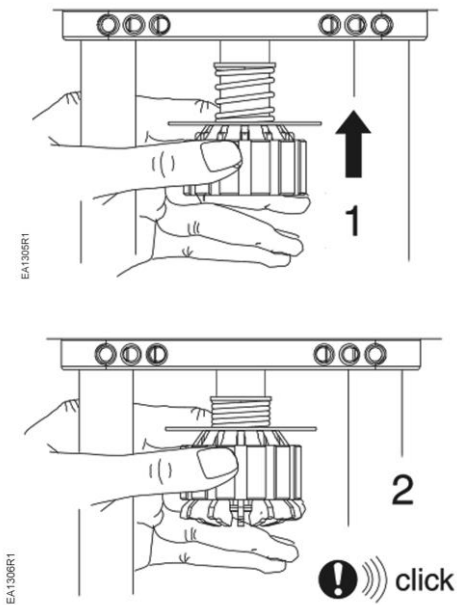

Figure 4.



WARNING:

Risk of injury due to fingers being trapped or pinched. Avoid contact with moving parts.

3. To engage the manual override crank, pull back the crank arm from its storage location until it springs into position. See Figure 5, Step 1.

4. To adjust the height of the stem connection:
 - a. Push the crank arm until the arm is parallel with the actuator.
 - b. Turn the handle until the actuator stem is fully retracted.
 - c. To lock the stem in place, position the handle at a 45° angle until you hear it snap into place. See Figure 5, Step 2.

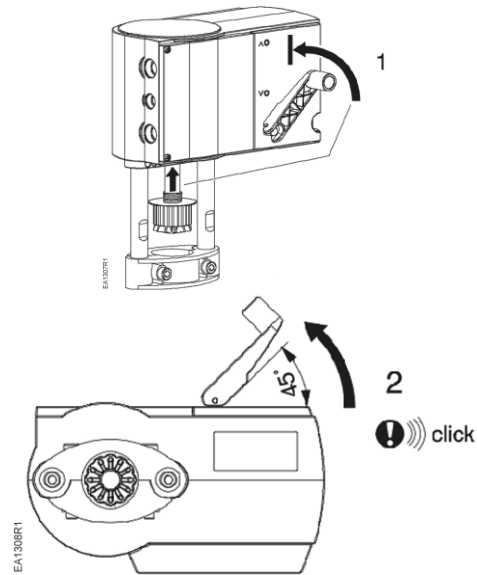

Figure 5.

Attaching the Actuator to the Valve

1. Place the actuator on the valve. See Figure 6, Step 1.
2. Using a 6 mm hex wrench, tighten the two hex head cap screws to secure the actuator to the valve body. See Figure 6, Step 2.
3. Insert the anti-rotation Device on the actuator arm as indicated. Figure 6, Step 3.

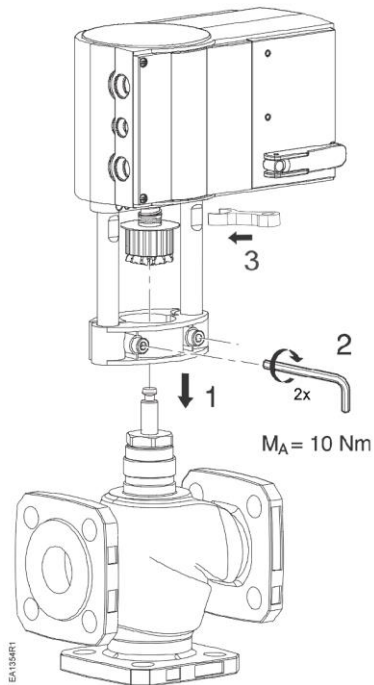

Figure 6.

4. Slide the anti-rotation device over the valve stem to a position approximately mid-way between the flats on the valve stem and the stem connection feature. See Figure 7.

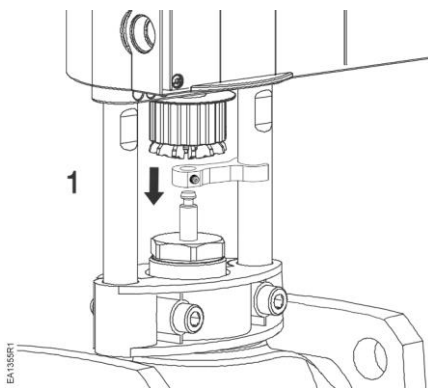

Figure 7.

5. Use a 2.5 mm hex wrench to tighten the anti-rotation device set screw to 35 to 62 in-lbs (4 to 7 Nm). See Figure 8.

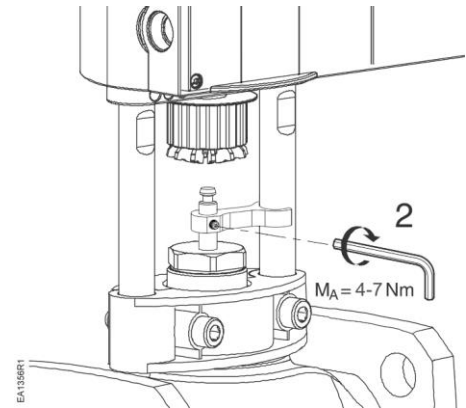

Figure 8.

Actuator/Valve Stem Connection

1. Push the crank arm until it is parallel with the actuator, then turn the crank arm in the proper direction to engage the actuator stem connection with the valve stem. See Figure 9.

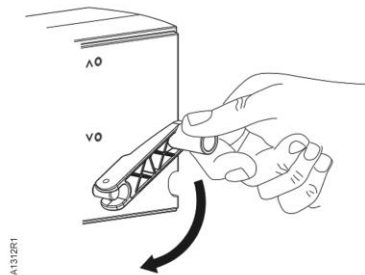

Figure 9.

Actuator/Valve Stem Connection, Continued

2. Crank down until you hear the stem connector snap into place. See Figure 10.

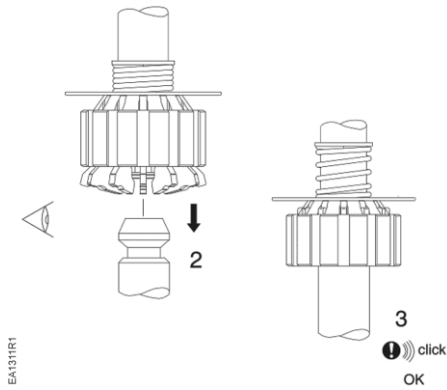

Figure 10.

3. Return the crank arm to its storage location.



CAUTION:

Do not rotate the actuator on the valve once the actuator and valve stem are connected, and/or the anti-rotation device is connected to the valve stem. Doing so will inadvertently adjust the flow setting of the valve.

DIP Switches

Switch coding	Characteristic (stroke/voltage)

Factory setting

EA1417R1

DIP Switch	Speed	Positioning Time ¹⁾	
		20 mm	40 mm
	2 seconds/mm	40 sec ²⁾	80 sec ²⁾
	3 seconds/mm	60 sec	120 sec
	4,5 seconds/mm	90 sec	180 sec
	6 seconds/mm	120 sec	240 sec

EA1388R1

- 1) Tolerance: ± 1 second
- 2) Factory setting

LED Status

EA1416R1		Initialization procedure / manual mode / waiting time after switching on after spring return	lit	flashing	dark
		stem is moving upwards			
		stem is moving downwards			
		position or limit stop reached			
		foreign object detected (blocked in corresponding direction)			
		no power supply			

Wiring Diagrams

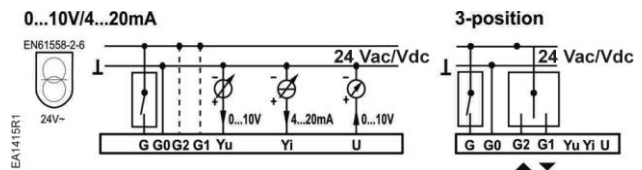

0 to 10V/4 to 20 mA

- G System Potential
- G0 System Neutral
- G1 Y = 0 Vdc/4 mA: Actuator fully extended (increasing control signal retracts actuator stem)
- G2 Y = 0 Vdc/4 mA: Actuator fully retracted, (increasing control signal extends actuator stem)
- Yu/Yi Control Signal 0 to 10V/4 to 20 mA
- U Position Indication

3-position

- G System Potential
- G0 System Neutral
- G1 Control signal: Actuator stem extends
- G2 Control signal: Actuator stem retracts

The installation is now complete.

Automatic Self-Calibration

When power is applied to the actuator for the first time, self-calibration takes place. During this process, both LEDs on the drive flash in red.

1. The stem extends until it reaches the lower mechanical stop in the valve.
2. Then, the stem retracts until it reaches the upper mechanical stop in the valve.
3. Self-calibration is complete. The valve and actuator move to the position dictated by the control signal.

Manual Self-Calibration

If required, self-calibration can be triggered manually.

- Fold out and fold back the crank handle twice within 4 seconds. See Figure 11. Self-calibration begins.
- The self-calibration can be stopped by folding out the crank handle again.

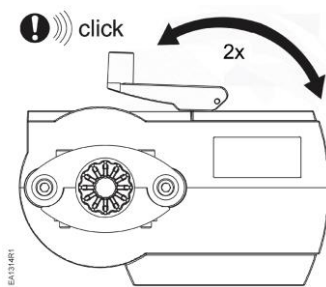

Figure 11.

- After calibration is complete, the two stroke indicator clips can be attached to the actuator arms. See Figure 12.

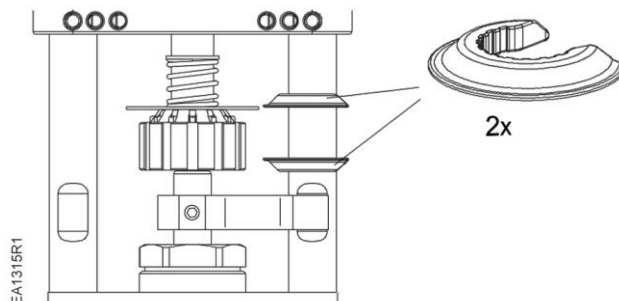

Figure 12. Stroke Indicators (Included).

Operation

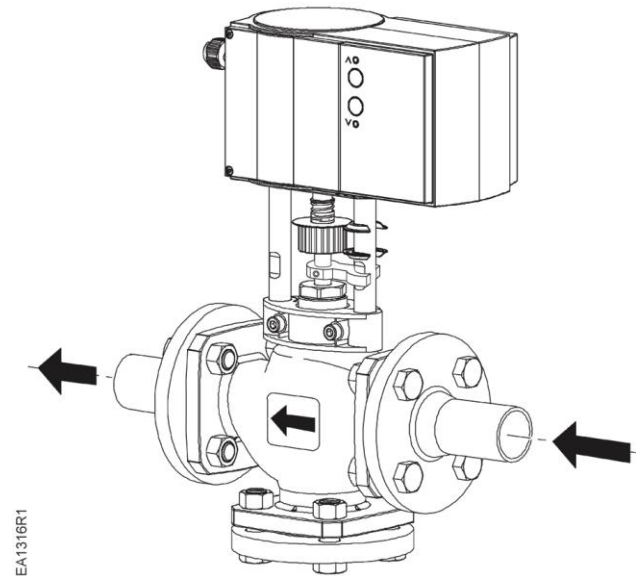

Figure 13.



CAUTION:

Observe the direction of flow when assembling the valve and actuator.

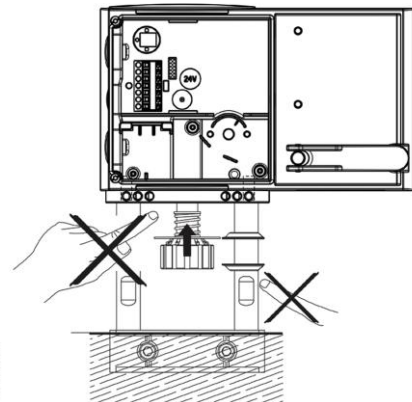

Figure 14.



WARNING:

Risk of injury due to fingers being trapped or pinched. Avoid contact with moving parts.



WARNING:

Risk of burns due to contact with hot surfaces. Avoid contact with hot surfaces.

Spring Return

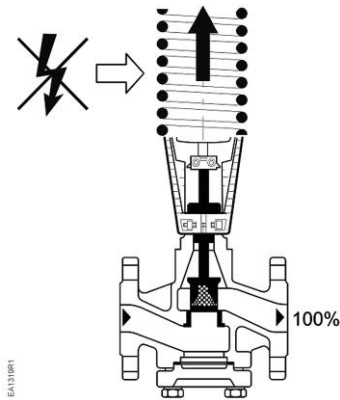

Figure 15. SQV91P30U Normally Open Actuator.

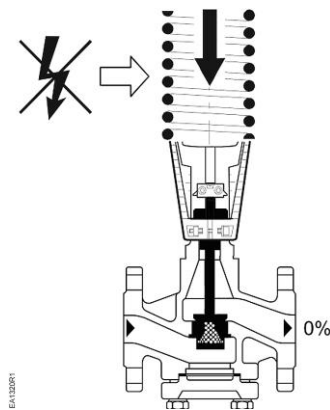

Figure 16. SQV91P40U Normally Closed Actuator.

Removing the Actuator from a Valve



WARNING:

Risk of injury due to fingers being trapped or pinched. Avoid contact with moving parts.



WARNING:

Risk of hand injury caused by spring under tension. Do not dismantle the spring.

1. Ensure that the differential pressure across the valve is zero. See Figure 17.

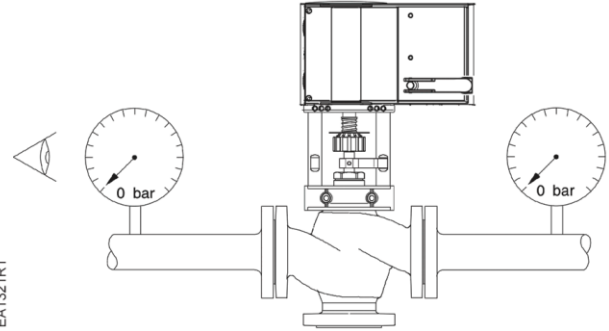

Figure 17.



WARNING:

Do not disassemble the actuator.

2. Disconnect the electrical power.
3. To engage the manual override crank, pull back the crank arm until it springs into position.
4. While pushing up on the actuator's stem connector, turn the crank arm in the appropriate direction to disengage the actuator stem connection from the valve stem. See Figure 18.

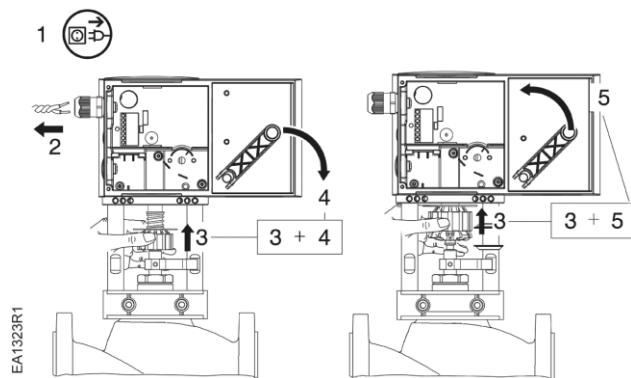

Figure 18.

Removing the Actuator from a Valve, Continued

5. Crank the actuator stem away from the valve stem enough to enable removal of the anti-rotation device.
6. Use a 2.5 mm hex wrench to loosen the anti-rotation device set screw.
7. Slide the anti-rotation device off the valve stem, and remove from the actuator arm.
8. Using a 6 mm hex wrench, loosen the two hex head cap screws on the bonnet connection. See Figure 19, Step 1.

NOTE: Only loosen the screws until flush with brackets; do not remove.

9. Pull straight up on the actuator to remove from the valve. See Figure 19, Step 2.

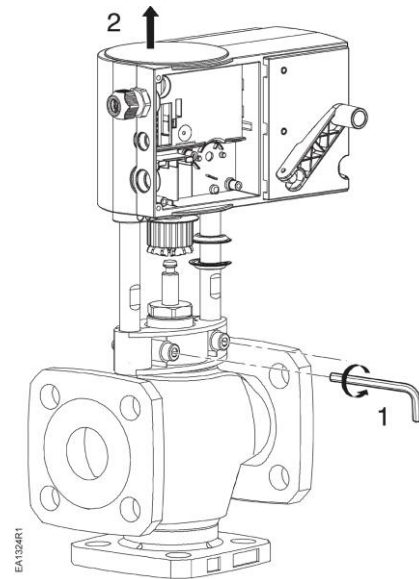
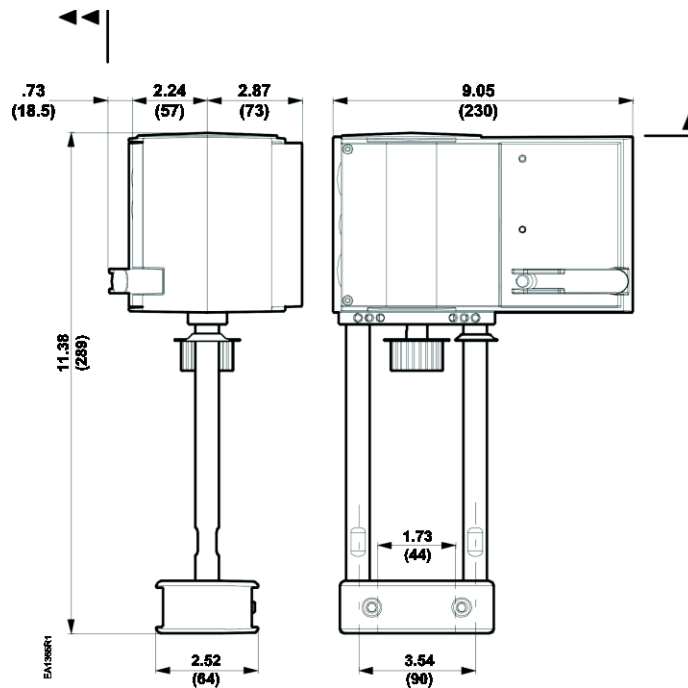

Figure 19. Removing the Actuator from the Valve.



▶	> 4 in. (100 mm)	Minimum mounting distance to wall or ceiling, for mounting, connection, operation, maintenance, and so on.
▶▶	> 8 in. (200 mm)	

Information in this publication is based on current specifications. The company reserves the right to make changes in specifications and models as design improvements are introduced. Product or company names mentioned herein may be the trademarks of their respective owners. © 2026 Siemens Industry, Inc.