



SAX..., SAY..



SAV..



SAL..



SAX61../MO,
SAY61../MO



SAV61../MO

Acvatix™

Actuators SAX..., SAY..., SAV..., SAL.. for valves

Basic Documentation

Siemens Switzerland Ltd
Smart Infrastructure
Global Headquarters
Theilerstrasse 1a
6300 Zug
Switzerland
Tel. +41 58-724 24 24
www.siemens.com/sbt

© Siemens Switzerland Ltd, 2010 - 2024
Subject to change

Contents

| | | |
|----------|---|-----------|
| 1 | About this documentation | 5 |
| 1.1 | Navigation / Quick access..... | 5 |
| 1.2 | Revision history..... | 7 |
| 1.3 | Reference documents..... | 8 |
| 1.4 | Before you start..... | 8 |
| 1.4.1 | Trademarks | 8 |
| 1.4.2 | Copyright..... | 8 |
| 1.4.3 | Quality assurance | 9 |
| 1.4.4 | Document use / request to the reader | 9 |
| 1.5 | Scope of this documentation..... | 9 |
| 2 | Engineering | 10 |
| 2.1 | Product description | 10 |
| 2.2 | Use..... | 11 |
| 2.3 | Type summary..... | 11 |
| 2.3.1 | Stroke actuators | 11 |
| 2.3.2 | Stroke actuators – combi valves | 12 |
| 2.3.3 | Rotary actuators..... | 12 |
| 2.4 | Ordering | 13 |
| 2.5 | Equipment combinations..... | 15 |
| 2.5.1 | Stroke actuators – 3-port valves | 15 |
| 2.5.2 | Stroke actuators – 2-port valves | 17 |
| 2.5.3 | Stroke Actuators – combi valves..... | 19 |
| 2.5.4 | Rotary actuators – slipper and butterfly valves..... | 20 |
| 2.6 | Accessories..... | 21 |
| 2.6.1 | Electrical accessories | 21 |
| 2.6.2 | Mechanical accessories | 22 |
| 2.7 | Product replacements | 22 |
| 2.7.1 | Stroke actuators SQX.. to SAX..... | 22 |
| 2.7.2 | Rotary actuators SQL.. to SAL..... | 23 |
| 2.7.3 | Electrical accessories | 23 |
| 2.8 | Spare parts..... | 24 |
| 2.9 | Sizing | 25 |
| 2.9.1 | Parallel operation of actuators | 25 |
| 2.9.2 | Permissible cable lengths and wire cross-sectional areas | 25 |
| 2.10 | Warranty..... | 26 |
| 3 | Handling..... | 27 |
| 3.1 | Mounting and installation | 27 |
| 3.1.1 | Mounting positions | 27 |
| 3.1.2 | Fitting stroke actuators to seat valves VVF.. / VXF.. or VVG.. / VXG..... | 27 |
| 3.1.3 | Avoid misalignment on V_G41 valves with fittings..... | 28 |
| 3.1.4 | Fitting rotary actuators to butterfly valves VKF41..... | 29 |
| 3.1.5 | Fitting rotary actuators to slipper valves VBF21..... | 31 |
| 3.1.6 | Fitting rotary actuators to butterfly valves VKF46..... | 34 |
| 3.1.7 | Fitting rotary actuators to butterfly valves VKF45..... | 35 |
| 3.1.8 | Fitting rotary actuators to butterfly valves VFL41..... | 37 |
| 3.1.9 | Fitting rotary actuators to butterfly valves VFW41..... | 38 |
| 3.1.10 | Fitting rotary actuators to butterfly valves VFW41U..... | 39 |
| 3.1.11 | Fitting accessories | 40 |
| 3.1.12 | Wiring (installation) | 46 |
| 3.2 | Commissioning and operation | 49 |
| 3.2.1 | Function check and Calibration..... | 49 |
| 3.2.2 | Commissioning Modbus RTU | 52 |
| 3.2.3 | Maintenance..... | 55 |
| 3.2.4 | Disposal | 55 |

| | | |
|----------|---|-----------|
| 4 | Functions and control | 56 |
| 4.1 | 3-position control | 56 |
| 4.1.1 | Combination with RVD.. controller for direct domestic hot water distribution by heat exchanger | 58 |
| 4.2 | Modulating control | 59 |
| 4.3 | Function module AZX61.1 | 60 |
| 4.3.1 | Sequence control (signal adaptation) | 60 |
| 4.3.2 | Changeover of acting direction | 61 |
| 4.4 | Positioning signal and flow characteristic | 62 |
| 4.5 | Acting direction and flow characteristic | 63 |
| 4.6 | Position Feedback U | 63 |
| 4.7 | Position control with ClosedPosition-Synchronization | 64 |
| 4.7.1 | ClosedPosition-Synchronization | 64 |
| 4.8 | Calibration | 65 |
| 4.9 | Signal priorities | 66 |
| 4.10 | Detection of valve seat | 66 |
| 4.11 | Detection of foreign bodies | 67 |
| 4.12 | Forced control Z | 68 |
| 4.13 | Communicating actuators Modbus RTU | 68 |
| 4.13.1 | Detection of valve seat | 68 |
| 4.13.2 | Detection of foreign bodies | 69 |
| 4.13.3 | Calibration | 70 |
| 4.13.4 | Manual adjustment | 70 |
| 4.13.5 | Modbus Registers | 71 |
| 4.13.6 | Function description | 73 |
| 4.14 | Technical and mechanical design | 75 |
| 4.14.1 | Transmission of power | 75 |
| 4.14.2 | Coupling | 76 |
| 4.14.3 | Manual adjuster | 76 |
| 4.14.4 | Indicators | 77 |
| 4.14.5 | Electrical accessories | 78 |
| 4.14.6 | Mechanical accessories | 79 |
| 5 | Technical data..... | 80 |
| 6 | Connection diagrams and dimensions | 83 |
| 6.1 | Internal diagrams | 83 |
| 6.2 | Connection terminals | 84 |
| 6.2.1 | Actuators | 84 |
| 6.2.2 | Electrical accessories | 84 |
| 6.3 | Connection diagrams | 85 |
| 6.4 | Dimensions | 87 |
| 6.4.1 | Stroke actuators | 87 |
| | ¹⁾ SAX..U: 1.850 kg | 87 |
| 6.4.2 | External Modbus converter | 88 |
| 6.4.3 | Rotary actuators | 88 |
| 7 | Revision numbers | 90 |
| 8 | Glossary | 91 |
| 8.1 | Symbols | 91 |
| 8.2 | Terms | 91 |

1 About this documentation

1.1 Navigation / Quick access

Information about a specific actuator is provided throughout the document. The structure of chapters 2 to 4 is as follows:

| | |
|--------------------------------|-----------------------------|
| 2 Projektierung | geräteorientiert |
| 2.1 Produktbeschreibung | |
| 2.2 Anwendung | |
| 3 Handhabung | handlungsorientiert |
| 3.1 Montage und Installation | |
| 3.2 Inbetriebnahme und Betrieb | |
| 4 Funktionen und Steuerung | baugruppenorientiert |
| 4.1 3-Punkt-Ansteuerung | |
| 4.2 Stetige Ansteuerung | |

4040286e

Quick access to important information including reference to pages:

| Product no. | 2 Engineering | | 3 Handling | | 4 Function and control | | | | | | | | |
|---------------------------|------------------------|-------------|-------------|------------------------|------------------------|-------------|--------------|------------|------------|------------|--------------|---------|--------------|
| | Equipment combinations | Accessories | Calibration | Accessories (mounting) | Control | Calibration | Accessories | | | | | | |
| SAX31.00 | Page 15 - 19 | Page 21 | - | Page 40-46 | Page 56-57 | - | Page 78 - 79 | | | | | | |
| SAX31.03 | | | - | | | | | | | | | | |
| SAX61.03 ¹⁾ | | | Page 49 | | Page 59 | Page 65 | | | | | | | |
| SAX61.03U ¹⁾ | | | | | Page 70 | | | | | | | | |
| SAX61.03/MO ¹⁾ | | | - | | Page 56-57 | - | | | | | | | |
| SAX81.00 ¹⁾ | | | Page 49 | | Page 59 | Page 65 | | | | | | | |
| SAX81.03 ¹⁾ | | | | | Page 70 | | | | | | | | |
| SAX81.03U ¹⁾ | | | - | | Page 56-57 | - | | | | | | | |
| SAX31P03 | | | Page 19 | | Page 21 | Page 49 | | Page 40-46 | Page 56-57 | Page 65 | Page 78 - 79 | | |
| SAX61P03 ¹⁾ | | | | | | | | | | Page 70 | | | |
| SAX61P03/MO ¹⁾ | | | | | | | | | | Page 65 | | | |
| SAX81P03 ¹⁾ | | | | | | | | | | Page 65 | | | |
| SAY31P03 | Page 15 - 19 | Page 21 | | - | | | Page 40-46 | | | Page 56-57 | | - | Page 78 - 79 |
| SAY61.00 ¹⁾ | | | | | | | | | | | | Page 65 | |
| SAY61.00U ¹⁾ | | | Page 70 | | | | | | | | | | |
| SAY61.00/MO ¹⁾ | | | Seite 49 | | | | | | | | | | |
| SAY81.00 ¹⁾ | | | - | | | | | | | | | | |
| SAY81.00U ¹⁾ | Page 49 | Page 59 | Page 65 | | | | | | | | | | |
| SAV31.00 | Page 15 - 19 | Page 21 | - | Page 40-46 | Page 56-57 | - | Page 78 - 79 | | | | | | |
| SAV61.00 ¹⁾ | | | Page 59 | | Page 65 | | | | | | | | |
| SAV61.00U ¹⁾ | | | Page 70 | | | | | | | | | | |
| SAV61.00/MO ¹⁾ | | | - | | Page 56-57 | - | | | | | | | |
| SAV81.00 ¹⁾ | | | Page 49 | | Page 59 | Page 65 | | | | | | | |
| SAV81.00U ¹⁾ | | | | | Page 70 | | | | | | | | |
| SAV31P00 | | | - | | Page 56-57 | - | | | | | | | |
| SAV61P00 ¹⁾ | | | Page 49 | | Page 59 | Page 65 | | | | | | | |
| SAV61P00/MO ¹⁾ | | | Page 70 | | | | | | | | | | |
| SAV81P00 ¹⁾ | - | Page 56-57 | - | | | | | | | | | | |

| Product no. | 2 Engineering | | 3 Handling | | 4 Function and control | | |
|-------------------------------|------------------------|-------------|-------------|------------------------|------------------------|-------------|--------------|
| | Equipment combinations | Accessories | Calibration | Accessories (mounting) | Control | Calibration | Accessories |
| SAL31.00T10 | Page 19 | Page 21 | - | Page 40-46 | Page 56-57 | - | Page 78 - 79 |
| SAL31.00T20 | | | | | | | |
| SAL31.00T40 | | | | | | | |
| SAL31.03T10 | | | | | | | |
| SAL31.03T10/F05 | | | | | | | |
| SAL61.00T10 ¹⁾ | | | Page 49 | | Page 59 | Page 65 | |
| SAL61.00T20 ¹⁾ | | | | | | | |
| SAL61.00T40 ¹⁾ | | | | | | | |
| SAL61.03T10 ¹⁾ | | | - | | Page 56-57 | - | |
| SAL61.03T10/F05 ¹⁾ | | | | | | | |
| SAL81.00T10 ¹⁾ | | | | | | | |
| SAL81.00T20 ¹⁾ | | | - | | Page 56-57 | - | |
| SAL81.00T40 ¹⁾ | | | | | | | |
| SAL81.03T10 ¹⁾ | | | | | | | |
| SAL81.03T10/F05 ¹⁾ | | | | | | | |

¹⁾ These types of actuator are UL-listed versions

Note

Glossary and Index are arranged at the end of the document.

1.2 Revision history

| Revision | Date | Changes | Chapter |
|---------------|------------|--|---|
| First edition | 16.07.2010 | - | - |
| 2.0 | 2010-12-12 | Rotary actuator SAL..T10 integrated | |
| | | Mounting and installation of butterfly valves and slipper valves corrected and expanded | 3.1 |
| | | New chapter „Position feedback U“ | 4.6 |
| | | Technical data corrected | 5 |
| 2.1 | 2011-09-14 | V..F53.. valves added | 2.5 |
| | | SAL..T20 rotary actuators added | 1.1, 1.2, 2.3, 2.4, 2.5, 2.6, 3, 3.1, 4.12, 5, 7 |
| 3 | 2012-09-12 | Corrections regarding SAX..Series „G“ “ VVF53.50-40K valve added | 2.4, 4.1, 4.7, 4.13, 5, 6.4 |
| 3.1 | 2013-12-17 | SAL..T40 is added | ... |
| 3.2 | 2014-11-20 | Supplemented with new valves V..F22, V..F32.., V..F42.. | 1.1, 1.3, 2.1, 2.2, 2.3, 2.4, 2.5, 2.6, 3.1, 4.1, 4.3, 4.4 4.13, 5, 6.1, 6.4, 7 |
| | | Supplemented with actuators SAV.. | 1.1, 1.3, 2.1, 2.2, 2.3, 2.4, 2.5, 2.6, 2.8, 4.1, 4.4, 4.7, 4.13, 5, 6.4, 7 |
| 3.3 | 2015-10-26 | Supplemented with actuators SAY..P.. | Various |
| 3.4 | 2016-10-04 | Actualization of headings with SAY.., added SAY.. to information on content and accessories | Various |
| 3.5 | 2017-05-26 | New: Communicating actuators (SAX61.03/MO) | Whole document |
| 3.6 | 2020-01-30 | New: Communicating actuators SAX61P03/MO, SAY61P03/MO, SAV61..MO New accessory: ASK32N | Various |
| | | Update to communicating actuators (parameters and functions) | 4.13 |
| 3.7 | 2022-05-19 | Changes for SA..31P, SA..61P and SA..81P Valve types: VXF43, VPF43, VFW41, FVL41, VFW41U und SAL../F05 added | Various |
| 3.8 | 2024-01-16 | Replaced various pictures (better quality) Footnote for hand-lever ASK41.. added LED-status “dark” added Corrections to connector diagram SA..61../MO Pictures SAL..T.. corrected Update revision numbers | Various 2.5.4 3.2.2 6.3 3.1.8, 3.1.9 7 |
| 3.9 | 2024-07-03 | Supplement: Power consumption values | 5 |
| 3.10 | 2024-09-04 | Reference document Characteristics | 1.3 |
| | | Modified: Modbus – Pushbutton operation, Parameter and function description | 3.22, 4.13.5 |
| | | Modified: Power consumption values | 5 |
| | | New: UKCA conformity | 5 |
| 3.11 | 2024-11-28 | Added: SAL..T10/F05 | 2.4 |
| | | Added: Marginal | 3.1.6, 3.1.8, 3.1.9, 3.1.10 |
| | | Modified: Content, illustration corrected | 5 |
| | | Modified: Stem heating element and function module | 5 |
| 3.12 | 2025-01-16 | Modified: Function module | 5 |
| 3.13 | 2025-02-27 | Modified: 515 Backup timeout maximum | 4.13.5 |
| 3.14 | 2025-10-22 | Modified: (SAX61.0.. 8...22 mm; SAV61.0.. 16...44 mm) | 4.8 |

1.3 Reference documents

| Type of document | SAX.. | SAV.. | SAY.. | SAL.. | |
|--|---|--------------|-------------|--|---------|
| Data Sheet | N4501, N4509, Q4501 | N4503, N4510 | A6V10628469 | N4502 | |
| Data Sheet Modbus communication profiles | A6V101037195 | - | - | - | |
| Commissioning/Configuration, valve actuator DIL switch characteristic overview | A6V12050595 | | | | |
| Mounting Instructions | - | - | - | ASK31N: M4502.1 ASK32N: A6V11558817 ASK33N: M4502.2 ASK35N: M4502.3 | |
| | ASC...: M4040.1 ASZ7.5: M4040.2 AZX61...: M4040.3 ASK39...: M4040.3 ASZ6.6: M4501 | | | - | |
| Mounting Instructions S..6../MO and G..161../MO | A5W00027551 | - | - | - | |
| CE Declaration of Conformity | AC 230 V | T4501X1 | T4503X1 | A5W00000333 | T4502X1 |
| | AC/DC 24 V | T4501X2 | T4503X2 | A5W00000333 | T4502X2 |
| Environmental Declaration | E4501 | E4503 | 7173310559B | E4502 | |
| Environmental Declaration, external Modbus converter | A6V101083254 | - | - | - | |
| Modbus over serial line - Specification and Implementation Guide | www.modbus.org | | | - | |

1.4 Before you start

1.4.1 Trademarks

The table below lists the third-party trademarks used in this document and their legal owners. The use of trademarks is subject to international and domestic provisions of the law.

| Trademarks | Legal owner |
|------------|-------------------------|
| Acvatix™ | Siemens Switzerland Ltd |

All product names listed in the table are registered (®) or not registered (™) trademarks of the owner listed in the table. We forgo the labeling (e.g. using the symbols ® and ™) of trademarks for the purposes of legibility based on the reference in this section.

1.4.2 Copyright

This document may be duplicated and distributed only with the express permission of Siemens, and may be passed on only to authorized persons or companies with the required technical knowledge.

1.4.3 Quality assurance

These documents were prepared with great care.

- The contents of all documents are checked at regular intervals
- All necessary corrections are included in subsequent versions
- Anpassungen bzw. Documents are automatically amended as a consequence of modifications and corrections to the products described

Please make sure that you are aware of the latest document revision date.

If you find lack of clarity while using this document, or if you have any criticisms or suggestions, please contact the product manager in your nearest branch office.

The addresses of the Siemens regional companies are available at www.siemens.com/acvatix.

1.4.4 Document use / request to the reader

Before using our products, it is important that you read the documents supplied with or ordered at the same time as the products (equipment, applications, tools etc.) carefully and in full.

We assume that persons using our products and documents are authorized and trained appropriately and have the technical knowledge required to use our products as intended.

More information on the products and applications is available:

- On the intranet (Siemens employees only) at <https://workspace.sbt.siemens.com/content/00001123/default.aspx>.
- From the Siemens branch office near you www.siemens.com/acvatix or from your system supplier.
- From the support team at headquarters fieldsupport-zug.ch.sbt@siemens.com if there is no local point of contact.

Siemens assumes no liability to the extent allowed under the law for any losses resulting from a failure to comply with the aforementioned points or for the improper compliance of the same.

1.5 Scope of this documentation

This document shall serve as a source of knowledge. In addition to basic information, it provides general technical information about the actuators used in HVAC plants. It is also targeted at engineering staff, HVAC electrical planners, system integrators and service engineers and provides all information required for planning work, correct installation, commissioning and service.

2 Engineering

2.1 Product description

The line of large actuators is comprised of stroke actuators SAX..., SAY..., SAV... and rotary actuators SAL...

Mechanical design

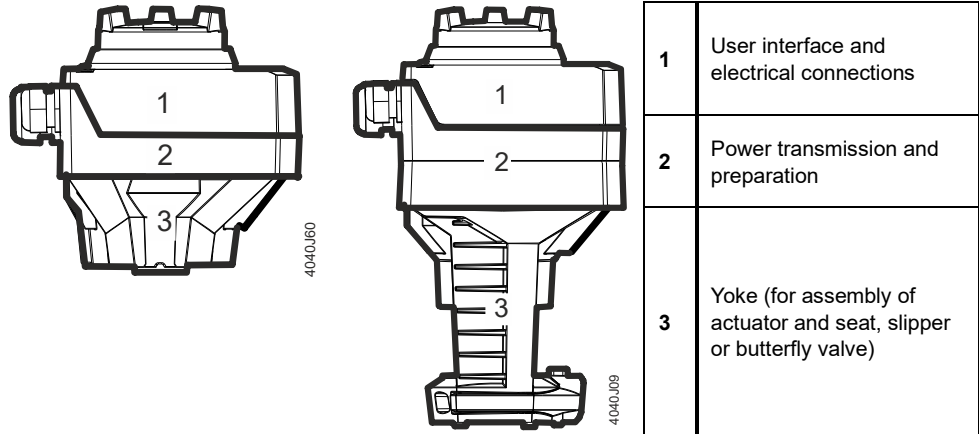

Components

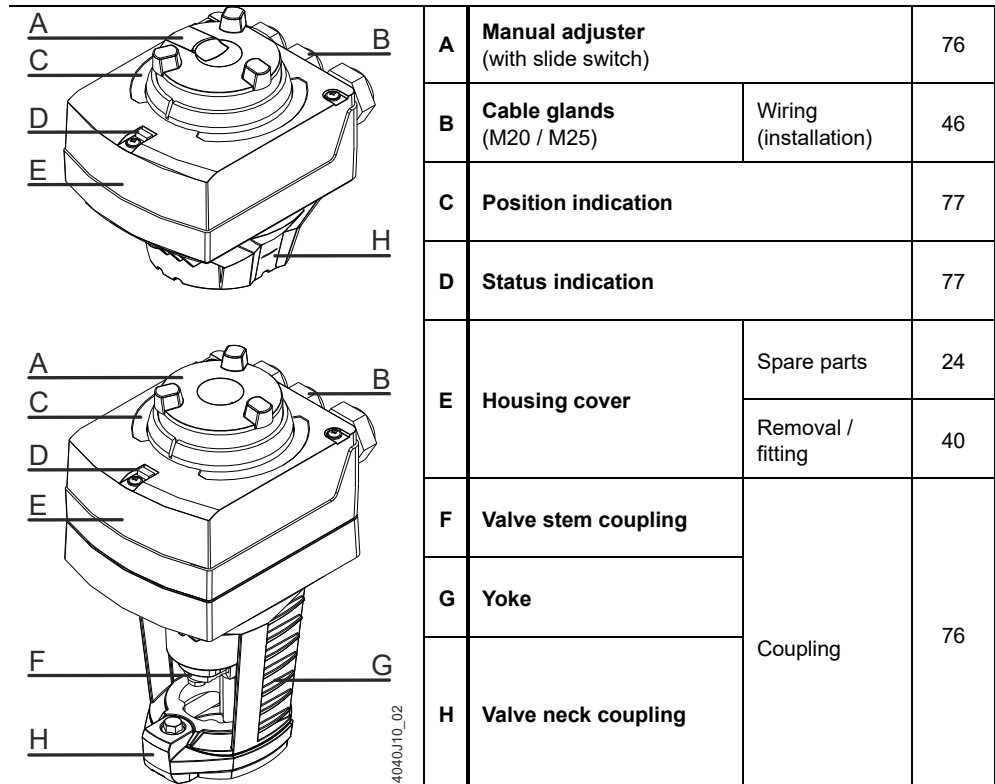

Network functions

See Section 3.2.2 Commissioning Modbus RTU

2.2 Use

SAX.., SAV..

For use in connection with Siemens 2-port or 3-port valves with 20/40 mm stroke, as control or shutoff valves for HVAC plants.

SAY..

For the operation of Siemens combi valves of type VPI46.40F9.5Q and VPI46.50F12Q with 15 mm stroke as control valves in ventilation, air conditioning, and district heating systems.

SAL..

For use in connection with Siemens butterfly or slipper valves, as control or shutoff valves for HVAC plants.

Note

When using the actuators outdoors, weather shield ASK39.1 must be fitted. SA..61../MO are not suitable for outdoor applications.

2.3 Type summary

2.3.1 Stroke actuators

| Product no. | Stock no. | Stroke | Pos. force | Operating voltage | Positioning signal | Spr. ret. time | Pos. time | LED | Manual ad-juster ¹⁾ | Extra functions | | | | |
|---|---------------------------------|--------|------------|----------------------|--------------------|----------------|-----------|----------------------|--------------------------------|-----------------|------------|---------------|---|---|
| SAX31.00 | S55150-A105 | 20 mm | 800 N | AC 230 V | 3-position | - | 120 s | - | Press and fix | - | | | | |
| SAX31.03 | S55150-A106 | | | | | | 30 s | ✓ | | | | | | |
| SAX61.03 SAX61.03U | S55150-A100 S55150-A100-A100 | | | AC 24 V / DC 24 V | Modbus RTU | | - | 30 s | | | ✓ | Press and fix | Position feedback, forced control, change of characteristic | |
| SAX61.03/MO ²⁾ | S55150-A140 | | | | | | | | | | | | Position feedback, forced control | |
| SAX81.00 | S55150-A102 | | | - | 3-position | | 120 s | - | | | - | - | - | |
| SAX81.03 SAX81.03U | S55150-A103 S55150-A103-A100 | | | | | | 30 s | - | | | | | | |
| SAV31.00 ³⁾ | S55150-A112 | 40 mm | 1600 N | AC 230 V | 3-position | - | 120 s | - | Press and fix | - | | | | |
| SAV61.00 ³⁾ SAV61.00U ³⁾ | S55150-A110 S55150-A110-A100 | | | | | | | AC 24 V / DC 24 V | | | Modbus RTU | - | 120 s | ✓ |
| SAV61.00/MO ²⁾ | S55150-A141 | | | 3-position | - | | | | | | | | | |
| SAV81.00 ³⁾ SAV81.00U ³⁾ | S55150-A111 S55150-A111-A100 | | | | | | | - | | | - | - | - | |

¹⁾ Not designed for continuous operation.

²⁾ Fixed connection cable 5 x 0.75 mm²

³⁾ SAV..: This product line of actuators might not be available in all countries. Please talk to your local contact or consult your local internet pages of www.buildingtechnologies.siemens.com.

2.3.2 Stroke actuators – combi valves

| Product no. | Stock no. | Stroke | Pos. force | Operating voltage | Positioning signal | Spr. ret. time | Pos. time | LED | Manual adjuster ¹⁾ | Extra functions | | | |
|--------------------|-------------|------------------|---|-------------------|---|----------------|-----------|----------|-------------------------------|---|---|---------------|---|
| SAY31P03 | S55150-A132 | 15 mm | 500 N | AC 230 V | 3-Point | - | 30 s | - | Press and fix | - | | | |
| SAY61P03 | S55150-A133 | | | AC 24 V /DC 24 V | DC 0...10 V DC 4...20 mA 0...1000 Ω | | | - | | 30 s | ✓ | Press and fix | Position feedback, forced control, change of characteristic |
| SAY61.03U | S55150-A135 | | | | Modbus RTU | | | | | | - | | - |
| SAY61P03/MO | S55150-A145 | | | | 3-Point | | | | | | - | | - |
| SAY81P03 | S55150-A134 | | | 20 mm | 500 N | | | AC 230 V | | 3-position | - | 30 s | - |
| SAX61P03 | S55150-A114 | AC 24 V /DC 24 V | DC 0...10 V DC 4...20 mA 0...1000 Ω | | | - | 30 s | ✓ | Press and fix | Position feedback, forced control, change of characteristic | | | |
| SAX61P03/MO | S55150-A143 | | Modbus RTU | | | | | - | | - | | | |
| SAX81P03 | S55150-A116 | | 3-position | | | | | - | | - | | | |
| SAV31P00 | S55150-A121 | 40 mm | 1100 N | AC 230 V | 3-position | - | 120 s | - | Press and fix | - | | | |
| SAV61P00 | S55150-A119 | | | AC 24 V /DC 24 V | DC 0...10 V DC 4...20 mA 0...1000 Ω | | | - | | 120 s | ✓ | Press and fix | Position feedback, forced control, change of characteristic |
| SAV61P00/MO | S55150-A144 | | | | Modbus RTU | | | | | | - | | - |
| SAV81P00 | S55150-A120 | | | | 3-position | | | | | | - | | - |

¹⁾ Not designed for continuous operation.

2.3.3 Rotary actuators

| Product no. | Stock no. | Angular rotation | Torque | Operating voltage | Positioning signal | Spr. ret. time | Pos. time | LED | Manual adjuster ¹⁾ | Extra functions | | | | | | | | |
|------------------------|-------------|------------------|--------|-------------------|---|----------------|-----------|-------|-------------------------------|-----------------|------------------|---|-------------|-------|-------|---------------|-----------------------------------|---|
| SAL31.00T10 | S55162-A108 | 90° | 10 Nm | AC 230 V | 3-position | - | 120 s | - | Press and fix | - | | | | | | | | |
| SAL31.00T20 | S55162-A110 | | 20 Nm | | | | | | | | | | | | | | | |
| SAL31.00T40 | S55162-A111 | | 40 Nm | | | | | | | | | | | | | | | |
| SAL31.03T10 | S55162-A109 | | 10 Nm | | | | | | | | AC 24 V /DC 24 V | DC 0...10 V DC 4...20 mA 0...1000 Ω | - | 120 s | ✓ | Press and fix | Position feedback, forced control | |
| SAL31.03T10/F05 | S55162-A121 | | | | | | | | | | | | | | | | | |
| SAL61.00T10 | S55162-A100 | | | | | | | | | | | | | | | | | |
| SAL61.00T20 | S55162-A102 | | 20 Nm | | | | | | | | | | | | | | | |
| SAL61.00T40 | S55162-A103 | | 40 Nm | | | | | | | | | | | | | | | |
| SAL61.03T10 | S55162-A101 | | 10 Nm | AC 24 V /DC 24 V | DC 0...10 V DC 4...20 mA 0...1000 Ω | | - | 120 s | | - | Press and fix | - | | | | | | |
| SAL61.03T10/F05 | S55162-A123 | | | | | | | | | | | | | | | | | |
| SAL81.00T10 | S55162-A104 | | | | | | | | | | | | | | | | | |
| SAL81.00T20 | S55162-A106 | | 20 Nm | | | | | | | | | | 3- position | - | 120 s | - | Press and fix | - |
| SAL81.00T40 | S55162-A107 | | 40 Nm | | | | | | | | | | | | | | | |
| SAL81.03T10 | S55162-A105 | | 10 Nm | 3- position | - | | 30 s | - | | Press and fix | - | | | | | | | |
| SAL81.03T10/F05 | S55162-A122 | | | | | | | | | | | | | | | | | |

¹⁾ Not designed for continuous operation.

2.4 Ordering

Example



| Product no. | Stock no. | Description | Quantity |
|-------------|-------------|---------------|----------|
| SAX81.03 | S55150-A103 | Actuator | 1 |
| ASZ7.5 | S55845-Z106 | Potentiometer | 1 |

Delivery

Actuators, valves and accessories are supplied in individual packs.



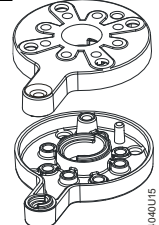
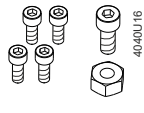
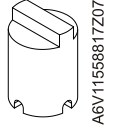
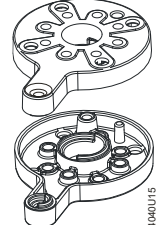
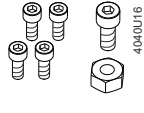
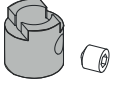
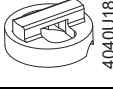
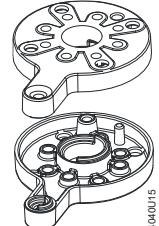
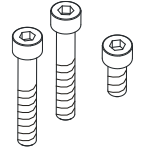

Scope of delivery





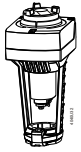

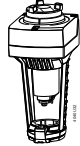

| Type | Device | Screws | Waveinsert |
|-----------------------|--------|--|--|
| SAX.. SAY..P.. | | - | - |
| SAX../MO, SAY../MO | | - | - |
| SAV.. | | - | - |
| SAV../MO | | - | - |
| SAL..T10 | | - | - |
| SAL..T10/F05 | | 2 pcs. M6 x 20 mm | 1 pc. 14 mm |
| SAL..T20 | | 2 pcs. M5 x 20 mm | 1 pc. 11 mm |
| SAL..T40 | | 2 pcs. M6 x 20 mm | 1 pc. 14 mm |
| ASK31N | | 4 pcs. M6 x 16 mm 1 pc. M5 x 20 mm incl. nut | 1 pc. 12 mm 1 pc. 12 mm |

| Type | Device | Screws | Waveinsert |
|--------|--|---|--|
| ASK32N |  4040U15 | 4 pcs. M6 x 16 mm 1 pc. M5 x 20 mm incl. nut  4040U16 | 1 pc. 12 mm  A6V11558817Z07 |
| ASK33N |  4040U15 | 4 pcs. M6 x 16 mm 1 pc. M5 x 20 mm incl. nut  4040U16 | 1 pc. 12 mm  4040U17 1 pc. 12 mm  4040U18 |
| ASK35N |  4040U15 | 2 pcs. M8 x 50 mm 1 pc. M5 x 20 mm incl. nut  4040U19 | 1 pc. 12 mm  16 mm 1 pc. 16 mm  12 mm |

2.5 Equipment combinations





2.5.1 Stroke actuators – 3-port valves





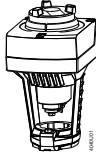
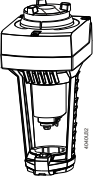

| Typical applications | Stroke actuators | Data Sheet | Stroke | | 20 mm | 40 mm | | |
|--|--|--------------------------------|-------------------|---|---|---|--|--|
| | | | Positioning force | | 800 N | 1600 N | | |
| <ul style="list-style-type: none"> • Heating plants • Ventilation and air conditioning plants • Heat generation • Heat distribution • District heating plants | SAX.. SAV.. ⁸⁾ | N4501 N4503 | | |  |  | | |
| | | | | | SAX.. | SAV.. | | |
| Valves | Basic Doc. (P4030) | | | | $\Delta p_{\max}^{5)}$ [kPa] AB→A B | $\Delta p_{\max}^{5)}$ [kPa] A→AB B | $\Delta p_{\max}^{5)}$ [kPa] AB→A B | $\Delta p_{\max}^{5)}$ [kPa] A→AB B |
| Valves | Data Sheet | Valve type | DN | k_{vs} [m³/h] | | | | |
| PN6  -10... 130 °C ⁴⁾ | N4410 | VXF21.22...25 ^{1) 7)} | 25 | 1.9 / 3 / 5 / 7.5 | 100 | 300 | | |
| | | VXF21.25... ^{2) 7)} | | 2.5 / 4 / 6.3 / 10 | | | | |
| | | VXF21.39-40 ⁷⁾ | 40 | 12 / 19 | | | | |
| | | VXF21.40... ^{2) 7)} | | 16 / 25 | | | | |
| | | VXF21.50 ⁷⁾ | 50 | 31 | | | | |
| | | VXF21.50-40 ⁷⁾ | | 40 | | | | |
| | | VXF21.65 ⁷⁾ | 65 | 49 | | | | |
| | | VXF21.65-63 ⁷⁾ | | 63 | | | | |
| | | VXF21.80-78 ⁷⁾ | 80 | 78 | | | | |
| | | VXF21.80-100 ⁷⁾ | | 100 | | | | |
| VXF21.90 ⁹⁾ | 100 | 124 | | | | | | |
| VXF21.100-160 ⁹⁾ | | 160 | | | | | | |
| PN6 -10... 130 °C | N4401 | VXF22.25... ²⁾ | 25 | 2.5 / 4 / 6.3 / 10 | 100 | 300 | | |
| | | VXF22.40... ²⁾ | | 16 / 25 | | | | |
| | | VXF22.50-40 | 50 | 40 | | | | |
| | | VXF22.65-63 | 65 | 63 | | | | |
| | | VXF22.80-100 | 80 | 100 | | | | |
| | | VXF22.100-160 | 100 | 160 | | | | |
| PN10  -10... 130 °C ⁴⁾ | N4420 | VXF31.15... ^{2) 7)} | 15 | 2.5 / 4 | 100 | 300 | | |
| | | VXF31.24...25 ^{1) 7)} | | 5 / 7.5 | | | | |
| | | VXF31.25... ^{2) 7)} | 25 | 6.3 / 10 | | | | |
| | | VXF31.39...40 ^{1) 7)} | | 12 / 19 | | | | |
| | | VXF31.40... ^{2) 7)} | 40 | 16 / 25 | | | | |
| | | VXF31.50 ⁷⁾ | | 50 | | | | |
| | | VXF31.50-40 ⁷⁾ | 40 | | | | | |
| | | VXF31.65 ⁷⁾ | 65 | 49 | | | | |
| | | VXF31.65-63 ⁷⁾ | | 63 | | | | |
| | | VXF31.80 ⁷⁾ | 80 | 78 | | | | |
| VXF31.80-100 ⁷⁾ | 100 | | | | | | | |
| PN 10 -10... 130 °C ⁴⁾ | N4402 | VXF32.15... ²⁾ | 15 | 1.6 / 2.5 | 100 | 400 | | |
| | | VXF32.25... ²⁾ | | 6.3 / 10 | | | | |
| | | VXF32.40... ²⁾ | 40 | 16 / 25 | | | | |
| | | VXF32.50-40 | | 50 | | | | |
| | | VXF32.65-63 | 65 | 63 | | | | |
| | | VXF32.80-100 | 80 | 100 | | | | |
| | | VXF32.100-160 | 100 | 160 | | | | |
| | | VXF32.125-250 | 125 | 250 | | | | |
| | | VXF32.150-400 | 150 | 400 | | | | |
| PN16  -10... 130 °C ⁴⁾ | N4430 | VXF40.15... ^{2) 7)} | 15 | 1.9 / 2.5 / 3 / 4 | 100 | 300 | | |
| | | VXF40.25... ^{2) 7)} | | 5 / 6.3 / 7.5 / 10 | | | | |
| | | VXF40.40... ^{2) 7)} | 40 | 12 / 16 / 19 / 25 | | | | |
| | | VXF40.50... ^{2) 7)} | | 31 / 40 | | | | |
| | | VXF40.65... ^{2) 7)} | 65 | 49 / 63 | | | | |
| | | VXF40.80... ^{2) 7)} | | 78 / 100 | | | | |
| PN16  -10... 130 °C ⁴⁾ | N4440 | VXF41.14...15 ^{1) 7)} | 15 | 1.9 / 3 | 200 | 800 | | |
| | | VXF41.24...25 ^{1) 7)} | | 5 / 7.5 | | | | |
| | | VXF41.39...40 ^{1) 7)} | 40 | 12 / 19 | | | | |
| | | VXF41.49...50 ^{1) 7)} | | 19 / 31 | | | | |

| Typical applications | Stroke actuators | Data Sheet | Stroke | | 20 mm | | 40 mm | | |
|--|------------------------------|-----------------------------------|-------------------|--|---|---|---|---|-----|
| | | | Positioning force | | 800 N | | 1600 N | | |
| <ul style="list-style-type: none"> • Heating plants • Ventilation and air conditioning plants • Heat generation • Heat distribution • District heating plants | SAX.. SAV.. ⁸⁾ | N4501 N4503 | | |  | |  | | |
| | | | | | SAX.. | | SAV.. | | |
| Valves | Basic Doc. (P4030) | | | $\Delta p_{max}^{5)}$ [kPa] | Δp_{max} [kPa] | $\Delta p_{max}^{5)}$ [kPa] | Δp_{max} [kPa] | | |
| Valves | Data Sheet | Valve type | DN | k_{vs} [m³/h] |  |  |  |  | |
| PN16  -10...130 °C ⁴⁾ | N4403 | VXF42.15-.. ²⁾ | 15 | 1.6 / 2.5 / 4 | 100 | 400 | - | - | |
| | | VXF42.20-6.3 | 20 | 6.3 | | | | | |
| | | VXF42.25-.. ²⁾ | 25 | 6.3 / 10 | | | | | |
| | | VXF42.40-.. ²⁾ | 40 | 16 / 25 | | | | | |
| | | VXF42.50-.. ²⁾ | 50 | 31.5 / 40 | | | | | |
| | | VXF42.65-.. ²⁾ | 65 | 50 / 63 | | | | | |
| | | VXF42.80-.. ²⁾ | 80 | 80 / 100 | | | | | |
| | | VXF42.100-.. ²⁾ | 100 | 125 / 160 | | | | | |
| PN16  -20...130 °C ⁴⁾ | N4404 | VXF43.65-50 | 65 | 50 | - | - | 100 | 400 | |
| | | VXF43.65-63 | 65 | 63 | | | | | |
| | | VXF43.80-80 | 80 | 80 | | | | | |
| | | VXF43.80-100 | 80 | 100 | | | | | |
| | | VXF43.100-125 | 100 | 125 | | | | | |
| | | VXF43.100-160 | 100 | 160 | | | | | |
| | | VXF43.125-200 | 125 | 200 | | | | | |
| | | VXF43.125-250 | 125 | 250 | | | | | |
| VXF43.150-315 | 150 | 315 | | | | | | | |
| VXF43.150-400 | 150 | 400 | | | | | | | |
| PN25/16 ⁶⁾  -20...130 °C ⁴⁾ | N4405 | VXF53.15-.. ²⁾ | 15 | 1.6 / 2.5 / 4 | 200 | 1200 | - | - | |
| | | VXF53.20-6.3 | 20 | 6.3 | | | | | |
| | | VXF53.25-.. ²⁾ | 25 | 6.3 / 10 | | | | | |
| | | VXF53.32-16 | 32 | 16 | | | | | |
| | | VXF53.40-.. ²⁾ | 40 | 16 / 25 | | | | | |
| | | VXF53.50-40 | 50 | 40 | | | | | |
| PN25 ⁶⁾ -20...130 °C ⁴⁾ | | VXF53.65-63 | 65 | 63 | - | - | 100 | 400 | |
| | | VXF53.80-100 | 80 | 100 | | | | | |
| | | VXF53.100-160 | 100 | 160 | | | | | |
| | | VXF53.125-250 | 125 | 250 | | | | | |
| | | VXF53.150-400 | 150 | 400 | | | | | |
| | | | | | | | | | |
| PN16  -25...130 °C ⁴⁾ | N4463 | VXG41.1301 ³⁾ | 15 | 1.6 | - | 800 | - | - | |
| | | VXG41.1401 ³⁾ | | 2.5 | | | | | |
| | | VXG41.15 VXG41.1501 ³⁾ | | 4 | | | | | |
| | | VXG41.20 VXG41.2001 ³⁾ | | 20 | | | | | 6.3 |
| | | VXG41.25 VXG41.2501 ³⁾ | | 25 | | | | | 10 |
| | | VXG41.32 VXG41.3201 ³⁾ | | 32 | | | | | 16 |
| | | VXG41.40 VXG41.4001 ³⁾ | | 40 | | | | | 25 |
| | | VXG41.50 VXG41.5001 ³⁾ | | 50 | | | | | 40 |

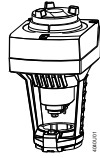
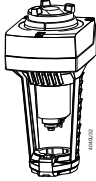
- 1) Insert running number instead of k_{vs} value
- 2) .. = insert k_{vs} value
- 3) With tight bypass; VXG41.1301 and VXG41.1401: use only SAX61..., SKD32.50 or SKD82.50.
- 4) For media temperatures > 130 °C use electrohydraulic actuators SKD.. (N4561), SKB.. (N4564).
- 5) Δp_{max}  = max. permissible differential pressure in diverting mode
- 6) DN 15...50: Flange dimensions for PN 16 and PN 25
DN 65...150: Flange dimensions only for PN 25
- 7) Valves no longer in the active sale
- 8) SAV..: This product line of actuators might not be available in all countries. Please talk to your local contact or consult your local internet pages of www.buildingtechnologies.siemens.com.
- 9) Only in combination with SKC..

2.5.2 Stroke actuators – 2-port valves

| Typical applications | Stroke actuators | Data Sheet | Stroke | | 20 mm | | 40°mm | | |
|--|------------------------------|--------------------------------|-------------------|--|---|--------------|---|--------------|------------------|
| | | | Positioning force | | 800 N | | 1600 N | | |
| <ul style="list-style-type: none"> • Heating plants • Ventilation and air conditioning plants • Heat generation • Heat distribution • District heating plants | SAX.. SAV.. ⁵⁾ | N4501 N4503 | | |  | |  | | |
| | | | | | SAX.. | | SAV.. | | |
| Valves | Basic Doc. (P4030) | | | | | Δp_s | Δp_{max} | Δp_s | Δp_{max} |
| Valves | Data Sheet | Valve type | DN | k_{vs} [m³/h] | [kPa] | [kPa] | [kPa] | [kPa] | |
| PN6  -10...130 °C ³⁾ | N4310 | VVF21.22...25 ^{1) 4)} | 25 | 1.9 / 3 / 5 / 7,5 | 600 | 300 | - | - | |
| | | VVF21.25... ^{2) 4)} | | 2.5 / 4 / 6.3 / 10 | | | | | |
| | | VVF21.39...40 ^{1) 4)} | 40 | 12 / 19 | 500 | | | | |
| | | VVF21.40... ^{2) 4)} | | 16 / 25 | | | | | |
| | | VVF21.50 ⁴⁾ | 50 | 31 | 300 | | | | |
| | | VVF21.50-40 ⁴⁾ | | 40 | | | | | |
| | | VVF21.65 ⁴⁾ | 65 | 49 | 175 | | | | |
| | | VVF21.65-63 ⁴⁾ | | 63 | | | | | |
| | | VVF21.80-78 ⁴⁾ | 80 | 78 | 100 | | | | |
| | | VVF21.80-100 ⁴⁾ | | 100 | | | | | |
| VVF21.90 ⁶⁾ | 100 | 124 | - | - | | | | | |
| VVF21.100-160 ⁶⁾ | 100 | 160 | - | - | | | | | |
| PN6 -10...130 °C | N4401 | VVF22.25... ²⁾ | 25 | 2.5 / 4 / 6.3 / 10 | 600 | 300 | - | - | |
| | | VVF22.40... ²⁾ | 40 | 16 / 25 | 550 | | 600 | 300 | |
| | | VVF22.50-40 | 50 | 40 | 350 | 200 | 150 | | 450 |
| | | VVF22.65-63 | 65 | 63 | 200 | 150 | 450 | 225 | |
| | | VVF22.80-100 ¹⁾ | 80 | 100 | 125 | 75 | 250 | 160 | 160 |
| VVF22.100-160 ¹⁾ | 100 | 160 | - | - | 160 | 160 | | | |
| PN10  -10...130 °C ³⁾ | N4320 | VVF31.15... ^{2) 4)} | 15 | 2.5 / 4 | 1000 | 300 | - | - | |
| | | VVF31.24...25 ^{1) 4)} | 25 | 5 / 7,5 | | | | | |
| | | VVF31.25... ^{2) 4)} | | 6.3 / 10 | 525 | | | | |
| | | VVF31.39...40 ^{1) 4)} | 40 | 12 / 19 | | | | | |
| | | VVF31.40... ^{2) 4)} | | 16 / 25 | 325 | | | | |
| | | VVF31.50 ⁴⁾ | 50 | 31 | | | | | |
| | | VVF31.50-40 ⁴⁾ | | 40 | 175 | | | | |
| | | VVF31.65 ⁴⁾ | 65 | 49 | | | | | |
| | | VVF31.65-63 ⁴⁾ | | 63 | 100 | | | | |
| VVF31.80 ⁴⁾ | 80 | 78 | | | | | | | |
| VVF31.80-100 ⁴⁾ | | 100 | 100 | | | | | | |
| PN10 -10...130 °C ⁴⁾ | N4402 | VVF32.15... ²⁾ | 15 | 1.6 / 2.5 / 4 | 1000 | 400 | - | - | |
| | | VVF32.25... ²⁾ | 25 | 6.3 / 10 | | | | | |
| | | VVF32.40... ²⁾ | 40 | 16 / 25 | 550 | 1000 | 400 | | |
| | | VVF32.50-40 | 50 | 40 | 350 | 300 | | 750 | |
| | | VVF32.65-63 | 65 | 63 | 200 | 150 | 450 | | |
| | | VVF32.80-100 ²⁾ | 80 | 100 | 125 | 75 | 250 | 225 | |
| | | VVF32.100-160 ²⁾ | 100 | 160 | - | - | 160 | 125 | |
| | | VVF32.125-250 | 125 | 250 | - | - | 125 | 90 | |
| VVF32.150-400 ²⁾ | 150 | 400 | - | - | 80 | 80 | | | |
| PN16  -10...130 °C ³⁾ | N4330 | VVF40.15... ^{2) 4)} | 15 | 1.9 / 2.5 / 3 / 4 | 1600 | 300 | - | - | |
| | | VVF40.25... ^{2) 4)} | 20 | 5 / 6.3 / 7.5 / 10 | 1550 | | | | |
| | | VVF40.40... ^{2) 4)} | 40 | 12 / 16 / 19 / 25 | 525 | | | | |
| | | VVF40.50... ^{2) 4)} | 50 | 31 / 40 | 325 | | | | |
| | | VVF40.65... ^{2) 4)} | 65 | 49 / 63 | 175 | 175 | | | |
| | | VVF40.80... ^{2) 4)} | 80 | 78 / 100 | 100 | 100 | | | |
| PN16  -10...130 °C ³⁾ | N4340 | VVF41.49 ⁴⁾ | 50 | 19 | 350 | 300 | - | - | |
| | | VVF41.50 ⁴⁾ | | 31 | | | | | |

| Typical applications | Stroke actuators | Data Sheet | Stroke | | 20 mm | | 40°mm | | | | |
|--|------------------------------|------------------------------|-------------------|--|---|------------------|---|------------------|---|-----|-----|
| | | | Positioning force | | 800 N | | 1600 N | | | | |
| <ul style="list-style-type: none"> • Heating plants • Ventilation and air conditioning plants • Heat generation • Heat distribution • District heating plants | SAX.. SAV.. ⁵⁾ | N4501 N4503 | | |  | |  | | | | |
| | | | | | SAX.. | | SAV.. | | | | |
| Valves | Basic Doc. (P4030) | | | | Δp_s | Δp_{max} | Δp_s | Δp_{max} | | | |
| Valves | Data Sheet | Valve type | DN | k_{vs} [m³/h] | [kPa] | [kPa] | [kPa] | [kPa] | | | |
| PN16  | N4403 | VVF42.15-.. ²⁾ | 15 | 1,6 / 2,5 / 4 | 1600 | 400 | - | - | | | |
| | | VVF42.20-6.3 | 20 | 6,3 | | | | | | | |
| | | VVF42.25-.. ²⁾ | 25 | 6,3 / 10 | | | | | | | |
| | | VVF42.32-16 | 32 | 16 | 900 | 400 | - | - | - | | |
| | | VVF42.40-.. ²⁾ | 40 | 16 / 25 | 550 | | | | | | |
| | | VVF42.50-.. ²⁾ | 50 | 31,5 / 40 | 350 | | | | | | |
| | | VVF42.65-.. ²⁾ | 65 | 50 / 63 | 200 | | | | | | |
| | | VVF42.80-.. ²⁾ | 80 | 80 / 100 | 125 | | | | | | |
| | | VVF42.100-.. ²⁾ | 100 | 125 / 160 | - | | | | | | |
| | | VVF42.125-.. ²⁾ | 125 | 200 / 250 | - | | | | | | |
| VVF42.150-.. ²⁾ | 150 | 315 / 400 | - | | | | | | | | |
| VVF42.150-360K | 150 | 360 | - | 1250 | 750 | | | | | 450 | 225 |
| VVF42.125-250K | 125 | 250 | - | 125 | 125 | | | | | 80 | 80 |
| VVF42.150-360K | 150 | 360 | - | 80 | 80 | - | - | | | | |
| PN16  | N4403 | VVF42.50-40K | 50 | 40 | 1600 | 400 | - | - | | | |
| | | VVF42.65-63K | 65 | 63 | | | | | | | |
| | | VVF42.80-100K | 80 | 100 | | | | | | | |
| | | VVF42.100-160K | 100 | 160 | - | - | 1600 | 400 | | | |
| | | VVF42.125-250K | 125 | 250 | - | - | 1400 | 400 | | | |
| | | VVF42.150-360K | 150 | 360 | - | - | 1400 | 400 | | | |
| PN16  | N4404 | VVF43.65-.. ²⁾ | 65 | 50 / 63 | - | - | - | - | | | |
| | | VVF43.80-.. ²⁾ | 80 | 80 / 100 | | | | | | | |
| | | VVF43.100-.. ²⁾ | 100 | 125 / 160 | | | | | | | |
| | | VVF43.125-.. ²⁾ | 125 | 200 / 250 | | | | | | | |
| | | VVF43.150-.. ²⁾ | 150 | 315 / 400 | | | | | | | |
| PN25  | N4373 | VVF52.15-.. ^{2) 4)} | 15 | 0.16 / 0.2 / 0.25 / 0.32 / 0.4 / 0.5 0.63 / 0.8 / 1 / 1.25 / 1.6 / 2 / 2.5 / 3.2 / 4 | 2500 | 1600 | - | - | | | |
| | | VVF52.25-.. ^{2) 4)} | 25 | 5 / 6.3 / 8 / 10 | 1500 | 1200 | - | - | | | |
| | | VVF52.40-.. ^{2) 4)} | 40 | 12.5 / 16 / 20 / 25 | 500 | 400 | - | - | | | |
| PN25/16  | N4405 | VVF53.15-.. ²⁾ | 15 | 0.16 / 0,2 / 0.25 / 0.32 / 0,4 / 0.5 / 0.63 / 0,8 / 1 / 1.25 / 1.6 / 2 / 2.5 / 3.2 / 4 | 2500 | 1200 | - | - | | | |
| | | VVF53.20-6.3 | 20 | 6.3 | | | | | | | |
| | | VVF53.25-.. ²⁾ | 25 | 5 / 6.3 / 8 / 10 | 1600 | - | | | - | | |
| | | VVF53.32-16 | 32 | 16 | 900 | | | | | | |
| | | VVF53.40-.. ²⁾ | 40 | 12.5 / 16 / 20 / 25 | 550 | | | | | | |
| | | VVF53.50-.. ²⁾ | 50 | 31.5 / 40 | 350 | | | | | | |
| | | VVF53.65-63 ⁶⁾ | 65 | 63 | - | | | | | | |
| VVF53.80-100 ⁶⁾ | 80 | 100 | - | | | | | | | | |
| VVF53.100-160 | 100 | 160 | - | 1250 | 1150 | | | | | | |
| VVF53.125-250 | 125 | 250 | - | 750 | 700 | | | | | | |
| VVF53.150-360 | 150 | 360 | - | 450 | 400 | | | | | | |
| VVF53.150-360 | 150 | 360 | - | 250 | 225 | | | | | | |
| VVF53.150-360 | 150 | 360 | - | 160 | 125 | | | | | | |
| VVF53.150-360 | 150 | 360 | - | 125 | 90 | | | | | | |
| VVF53.150-360 | 150 | 360 | - | 80 | 60 | | | | | | |
| PN16  | N4363 | VVG41.11...12 ¹⁾ | 15 | 0.63 / 1 | 1600 | 800 | - | - | | | |
| | | VVG41.13 | 15 | 1.6 | | | | | | | |
| | | VVG41.14 | 15 | 2.5 | | | | | | | |
| | | VVG41.15 | 15 | 4 | | | | | | | |
| | | VVG41.20 | 20 | 6.3 | 1550 | - | | | - | | |
| | | VVG41.25 | 25 | 10 | | | | | | | |
| | | VVG41.32 | 32 | 16 | | | | | | | |
| | | VVG41.40 | 40 | 25 | | | | | | | |
| VVG41.50 | 50 | 40 | 525 | 525 | | | | | | | |
| VVG41.50 | 50 | 40 | 300 | 300 | | | | | | | |

¹⁾ Insert running number instead of k_{vs} value

²⁾ .. = insert k_{vs} value

³⁾ For media temperatures > 130 °C use electrohydraulic actuators SKD.. (N4561), SKB.. (N4564).

⁴⁾ Valves no longer in the active sale







⁵⁾ SAV..: This product line of actuators might not be available in all countries. Please talk to your local contact or consult your local internet pages of www.buildingtechnologies.siemens.com

⁶⁾ Only in combination with SKC..

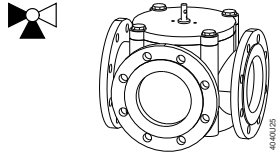
2.5.3 Stroke Actuators – combi valves

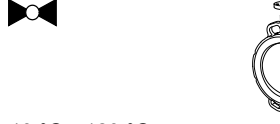
| | Valves | | | | Actuators | | | | | |
|----------------------------|--------------------|----------------|-----|------------------|---------------------------|-----------------------|---------------------------|-----------------------|---------------------------|-----------------------|
| | Standard flow rate | High flow rate | DN | H ₁₀₀ | SAY..P.. | | SAX..P.. | | SAV..P.. | |
| | | | | [mm] | Δp_{max} [kPa] | Δp_s [kPa] | Δp_{max} [kPa] | Δp_s [kPa] | Δp_{max} [kPa] | Δp_s [kPa] |
| PN25 N4855 | VPI46.40F9.5Q | - | 40 | 15 | 400 | 400 | - | - | - | - |
| | VPI46.50F12Q | - | 50 | | | | | | | |
| PN16 A6V12273951 | VPF43.50F16 | VPF43.50F25 | 50 | 20 | - | - | 600 | 600 | - | - |
| | VPF43.65F24 | VPF43.65F35 | 65 | | | | | | | |
| | VPF43.80F35 | VPF43.80F45 | 80 | | | | | | | |
| | VPF43.100F70 | VPF43.100F90 | 100 | 40 | - | - | - | - | 600 | 600 |
| | VPF43.125F110 | VPF43.125F135 | 125 | | | | | | | |
| | VPF43.150F160 | VPF43.150F200 | 150 | 43 | - | - | - | - | 600 | 600 |
| | VPF43.200F210 | VPF43.200F280 | 200 | | | | | | | |
| | VPF44.50F15 | VPF44.50F25 | 50 | 20 | - | - | 600 | 700 | - | - |
| | VPF44.65F25 | VPF44.65F35 | 65 | | | | | | | |
| | VPF44.80F35 | VPF44.80F45 | 80 | | | | | | | |
| VPF44.100F70 | VPF44.100F90 | 100 | 40 | - | - | - | - | 600 | 700 | |
| PN25 A6V12273951 | VPF53.50F16 | VPF53.50F25 | 50 | 20 | - | - | 600 | 600 | - | - |
| | VPF53.65F24 | VPF53.65F35 | 65 | | | | | | | |
| | VPF53.80F35 | VPF53.80F45 | 80 | | | | | | | |
| | VPF53.100F70 | VPF53.100F90 | 100 | 40 | - | - | - | - | 600 | 600 |
| | VPF53.125F110 | VPF53.125F135 | 125 | | | | | | | |
| | VPF53.150F160 | VPF53.150F200 | 150 | 43 | - | - | - | - | 600 | 600 |
| | VPF53.200F210 | VPF53.200F280 | 200 | | | | | | | |
| | VPF54.50F15 | VPF54.50F25 | 50 | 20 | - | - | 600 | 700 | - | - |
| | VPF54.65F25 | VPF54.65F35 | 65 | | | | | | | |
| | VPF54.80F35 | VPF54.80F45 | 80 | | | | | | | |
| VPF54.100F70 | VPF54.100F90 | 100 | 40 | - | - | - | - | 600 | 700 | |

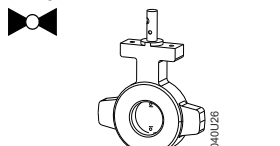
2.5.4 Rotary actuators – slipper and butterfly valves

| Typical applications | Rotary actuators | Data Sheet | Angular rotation | | | |
|--|-------------------|--------------------------|---|------------------------------|-----------------------------|-------------------------------|
| | | | Torque | | | |
| | | | 90° | | | |
| | | | 10 Nm | 20 Nm | 40 Nm | |
| <ul style="list-style-type: none"> • Heating plants • Ventilation and air conditioning plants • Heat generation • Heat distribution • District heating plants | SAL.. | N4502 |  | | | |
| | | | | | | SAL..T10 |
| Slipper valves | Data Sheet | Valve type | DN | k_{vs} [m³/h] | Mounting set | Δp_{max} [kPa] |
| PN6  1 °C...120 °C | N4241 | VBF21.40 | 40 | 25 | ASK32N | 30 |
| | | VBF21.50 | 50 | 40 | | |
| | | VBF21.65 | 65 | 63 | | |
| | | VBF21.80 | 80 | 100 | ASK31N | |
| | | VBF21.100 | 100 | 160 | | |
| | | VBF21.125 | 125 | 550 | | |
| | | VBF21.150 | 150 | 820 | | |
| Butterfly valves | | | | | Δp_s [kPa] | |
| PN16  -10 °C...120 °C | A6V101029242 | VFL41.40 ¹⁾ | 40 | 40 | ASK41NF04SP ⁶⁾ | - |
| | | VFL41.50 ¹⁾ | 50 | 100 | | |
| | | VFL41.65 ¹⁾ | 65 | 155 | | |
| | | VFL41.80 ¹⁾ | 80 | 260 | ASK41NF05SP ⁶⁾ | |
| | | VFL41.100 ¹⁾ | 100 | 520 | | |
| | | VFL41.125 ¹⁾ | 125 | 820 | | |
| PN16  -10 °C...120 °C | A6V101029242 | VFW41.40 ¹⁾ | 40 | 40 | ASK41NF04SP ⁶⁾ | - |
| | | VFW41.50 ¹⁾ | 50 | 100 | | |
| | | VFW41.65 ¹⁾ | 65 | 155 | | |
| | | VFW41.80 ¹⁾ | 80 | 260 | ASK41NF05SP ⁶⁾ | |
| | | VFW41.100 ¹⁾ | 100 | 520 | | |
| | | VFW41.125 ¹⁾ | 125 | 820 | | |
| PN16  -10 °C...120 °C | A6V101029254 | VFW41.40U ²⁾ | 40 | 40 | - | 500 |
| | | VFW41.50U ²⁾ | 50 | 100 | | |
| | | VFW41.65U ²⁾ | 65 | 155 | | |
| | | VFW41.80U ²⁾ | 80 | 260 | | |
| | | VFW41.100U ²⁾ | 100 | 520 | | |
| | | VFW41.125U ²⁾ | 125 | 820 | | |
| | | VFW41.150U ³⁾ | 150 | 1600 | | |
| | | VFW41.200U ³⁾ | 200 | 4000 | | |
| PN16  -10 °C...120 °C | N4131 | VKF41.40 ⁴⁾ | 40 | 50 | ASK33N | 500 |
| | | VKF41.50 ⁴⁾ | 50 | 80 | | |
| | | VKF41.65 ⁴⁾ | 65 | 200 | | |
| | | VKF41.80 ⁴⁾ | 80 | 400 | | |
| | | VKF41.100 ⁴⁾ | 100 | 760 | | |
| | | VKF41.125 ⁴⁾ | 125 | 1000 | | |
| | | VKF41.150 ⁵⁾ | 150 | 2100 | ASK33N | |
| | | VKF41.200 ⁵⁾ | 200 | 4000 | | |
| PN16  -10 °C...120 °C | N4136 | VKF46.40 ¹⁾ | 40 | 50 | - | - |
| | | VKF46.50 ¹⁾ | 50 | 85 | | |
| | | VKF46.65 ¹⁾ | 65 | 215 | | |
| | | VKF46.80 ¹⁾ | 80 | 420 | | |
| | | VKF46.100 ¹⁾ | 100 | 800 | | |
| | | VKF46.125 ¹⁾ | 125 | 1010 | | |

- 1) VFW41.., VFL41.., VKF46.. maximum flow speed water = 4.5 m/s, air 40 m/s
- 2) VFW41..U maximum flow speed water for SAL31.. and SAL81.. = 4 m/s and SAL61.. = 2.5 m/s
- 3) VFW41.150U and VFW41.200U maximum flow speed for SAL31.. and SAL81.. = 2.5 m/s and SAL61.. = 1.5 m/s
- 4) VKF41.. maximum flow speed with SAL.T10 actuator with water DN40.. DN125 = 4 m/s
- 5) VKF41.. maximum flow speed with SAL.T0 actuator with water DN150/200 = 2.5 m/s, with SAL.T40 actuator with water DN150/200 = 4 m/s
- 6) Only the hand lever ASK41.. or an actuator can be mounted, not both.

2.6 Accessories

2.6.1 Electrical accessories

| Product no. | Auxiliary switch ASC10.51 | Potentiometer ASZ7.5 ¹⁾ | Function module AZX61.1 | Stem heating element ASZ6.6 |
|-------------|------------------------------|---------------------------------------|----------------------------|-----------------------------------|
| Stock no. | S55845-Z103 | S55845-Z106 | S55845-Z107 | S55845-Z108 |
| | | Max. 2 | | Max. 1 |
| SAX31.. | Max. 2 | Max. 1 | - | Max. 1 |
| SAX61.. | | - | Max. 1 | |
| SAX61.03/MO | | - | - | |
| SAX81.. | | Max. 1 | - | |
| SAX31P.. | Max. 2 | Max. 1 | - | - |
| SAX61P.. | | - | Max. 1 | |
| SAX61P03/MO | | - | - | |
| SAX81P.. | | Max. 1 | - | |
| SAV31.. | Max. 2 | Max. 1 | - | Max. 1 |
| SAV61.. | | - | Max. 1 | |
| SAV61.00/MO | | - | - | |
| SAV81.. | | Max. 1 | - | |
| SAV31P.. | Max. 2 | Max. 1 | - | - |
| SAV61P.. | | - | Max. 1 | |
| SAV61P00/MO | | - | - | |
| SAV81P.. | | Max. 1 | - | |
| SAL31.. | Max. 2 | Max. 1 | - | - |
| SAL61.. | | - | Max. 1 | |
| SAL81.. | | Max. 1 | - | |
| SAY31P.. | Max. 2 | Max. 1 | - | - |
| SAY61P.. | | - | Max. 1 | |
| SAY61P03/MO | | - | - | |
| SAY81P.. | | Max. 1 | - | |

Notes on ASZ7.5 ¹⁾

For the combination SIMATIC S5/S7 and position feedback message, we recommend actuators with DC 0...9.8 V feedback signals.

The signal peaks that occur in the potentiometer ASZ7.5 may result in error messages on Siemens SIMATIC.

This is not the case when combined with Siemens HVAC controllers.

The reason is that SIMATIC has a higher resolution and faster response time.

Use a 3-wire connection as the voltage divider for the potentiometer.

Powering the potentiometer over the wiper may result in a shorter lifecycle.

Signal peaks occurring in this operating mode increase in frequency and severity throughout its lifecycle.

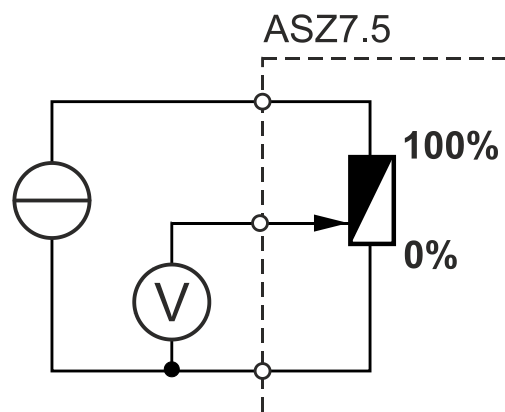

2.6.2 Mechanical accessories

| Product no. | Weather shield ASK39.1 ¹⁾ | Mounting set | | | | |
|-------------|---|-----------------------|-----------------------|---|-----------------------|-------------------------------------|
| | | ASK31N for VBF21.. | ASK32N for VBF21.. | VBI31.. ²⁾ VCI31.. ²⁾ VBG31.. ²⁾ | ASK33N for VKF41.. | ASK35N for VKF45.. ³⁾ |
| Stock no | S55845-Z109 | S55845-Z100 | S55845-Z211 | | S55845-Z101 | S55845-Z102 |
| SAY.. | Max. 1 | - | - | | - | - |
| SAX.. | | - | - | | - | - |
| SAV.. | | - | - | | - | - |
| SAL.. | | - | - | | - | - |
| SAL..T10 | Max. 1 | DN 65...150 | DN 40...50 | ✓ | ✓ | - |
| SAL..T20 | | - | - | - | - | DN 40...65 |
| SAL..T40 | | - | - | - | - | DN 150...200 DN 80...200 |

¹⁾ SA..61../MO are not suitable for outdoor applications.

²⁾ Types VBI31.., VCI31.., and VBG31.. are available only while stock lasts from 2019 on.

³⁾ In 2000 VKF45.. line was replaced by VKF46.. line.

2.7 Product replacements

Replacement of SQX.. / SQL.. actuators by SAX.. / SAL.. actuators.

Note

- When replacing actuators consider positioning force, torque and positioning times.
- Adjust in the controller the parameter "Running time" respectively "Positioning time", to ensure stable control.
- The replacement of accessory items needs to be taken into consideration also. In that case, compatibility is not necessarily ensured.

2.7.1 Stroke actuators SQX.. to SAX..

| SQX.. | | Pos. time [s] | Pos. force [N] | SAX.. | | Pos. time [s] | Pos. force [N] | VVF21../VXF21.. VVF31../VXF31.. VVF40../VXF40.. | VVF41../VXF41.. VVG41../VXG41.. | VVF51.. VVF52.. |
|-----------------------|-----------|------------------|-------------------|-----------|-----|------------------|-------------------|---|------------------------------------|--------------------|
| | | | | | | | | DN15...80 | DN15...50 | DN15...40 |
| SQX31.. ¹⁾ | SQX31.00 | 150 | 500 | SAX31.00 | 120 | 800 | | ✓ | ✓ | ✓ |
| | SQX31.03 | 35 | 500 | SAX31.03 | 30 | 800 | | ✓ | ✓ | ✓ |
| SQX61.. | SQX61 | 35 | 500 | SAX61.03 | 30 | 800 | | ✓ | ✓ | ✓ |
| | SQX61U | 35 | 500 | SAX61.03U | 30 | 800 | | ✓ | ✓ | ✓ |
| SQX81.. | SQX81.00 | 150 | 500 | SAX81.00 | 120 | 800 | | ✓ | ✓ | ✓ |
| | SQX81.00U | 150 | 500 | SAX81.00U | 120 | 800 | | ✓ | ✓ | ✓ |
| | SQX81.03 | 35 | 500 | SAX81.03 | 30 | 800 | | ✓ | ✓ | ✓ |
| | SQX81.03U | 35 | 500 | SAX81.03U | 30 | 800 | | ✓ | ✓ | ✓ |
| SQX32.. | SQX32.00 | 150 | 700 | SAX31.00 | 120 | 800 | | ✓ | ✓ | ✓ |
| | SQX32.03 | 35 | 700 | SAX31.03 | 30 | 800 | | ✓ | ✓ | ✓ |
| SQX62.. | SQX62 | 35 | 700 | SAX61.03 | 30 | 800 | | ✓ | ✓ | ✓ |
| | SQX62U | 35 | 700 | SAX61.03U | 30 | 800 | | ✓ | ✓ | ✓ |
| SQX82.. | SQX82.00 | 150 | 700 | SAX81.00 | 120 | 800 | | ✓ | ✓ | ✓ |
| | SQX82.00U | 150 | 700 | SAX81.00U | 120 | 800 | | ✓ | ✓ | ✓ |
| | SQX82.03 | 35 | 700 | SAX81.03 | 30 | 800 | | ✓ | ✓ | ✓ |
| | SQX82.03U | 35 | 700 | SAX81.03U | 30 | 800 | | ✓ | ✓ | ✓ |

¹⁾ SQX31.06: Actuator for gas valves. Either replace complete valve-actuator combination or clarify required positioning time and replace only actuator. Consider if mounting set is required.

2.7.2 Rotary actuators SQL.. to SAL..

| SQL.. | | | | SAL.. | | |
|---------|----------|---------------|-------------|---|---------------|-------------|
| | | Pos. time [s] | Torque [Nm] | | Pos. time [s] | Torque [Nm] |
| SQL31.. | SQL31.10 | 120 | 12,5 | SAL31.00T10 | 120 | 10 |
| SQL32.. | SQL32.10 | 125 | 12,5 | SAL31.00T10 | 120 | 10 |
| | SQL32.12 | 70 | 12,5 | SAL31.00T10 or SAL31.03T10 ¹⁾ | 120 30 | 10 10 |
| | SQL32.13 | 30 | 5 | SAL31.03T10 | 30 | 10 |
| SQL33.. | SQL33.00 | 125 | 12,5 | SAL31.00T10 | 120 | 10 |
| | SQL33.03 | 30 | 10 | SAL31.03T10 | 30 | 10 |
| SQL83.. | SQL83.00 | 125 | 12,5 | SAL81.00T10 | 120 | 10 |
| | SQL83.04 | 30 | 10 | SAL81.03T10 | 30 | 10 |
| SQL35.. | SQL35.00 | 125 | 20 | SAL31.00T20 ²⁾ | 120 | 20 |
| | SQL35.00 | 125 | 20 | SAL31.00T40 ²⁾ | 120 | 40 |
| SQL85.. | SQL85.00 | 125 | 20 | SAL81.00T20 ²⁾ | 120 | 20 |
| | SQL85.00 | 125 | 20 | SAL81.00T40 ²⁾ | 120 | 40 |

¹⁾ SAL.. positioning time differs from that of SQL32.12 and SQL32.13 rotary actuators. Consider positioning time when replacing.

²⁾ use SAL.T20 on VKF46.40, VKF46.50 and VKF46.65
use SAL.T40 on VKF46.80, VKF46.100 and VKF46.125

| Rotary actuators | | SQL.. | | | | SAL.. | | |
|------------------|-----------------------------|---------|---------|--------------------|--------------------|--|----------------------------|----------------------------|
| | | SQL31.. | SQL32.. | SQL33.. SQL83.. | SQL35.. SQL85.. | SAL31.00T10 SAL31.03T10 SAL81.00T10 SAL81.03T10 | SAL31.00T20 SAL81.00T20 | SAL31.00T40 SAL81.00T40 |
| VBF21.. | DN 40 / DN 50 ¹⁾ | - | - | ASK32 | - | ASK32N | - ¹⁾ | - ¹⁾ |
| | DN 65...150 | - | - | ASK31 | - | ASK31N | - | - |
| VBF31.. | DN 40 / DN 50 ²⁾ | - | - | ASK32 | - | ASK32N | - ²⁾ | - ²⁾ |
| | DN 65...100 | - | - | ASK31 | - | ASK31N | - | - |
| B3f.. | DN 40 / DN 50 ²⁾ | Direct | ASK25 | ASK31 | - | - | - | - |
| | DN 65...150 | Direct | ASK25 | ASK31 | - | ASK31N | - | - |
| C1f.. | DN 40 / DN 50 ²⁾ | Direct | - | ASK31 | - | - | - | - |
| | DN 65...100 | Direct | - | ASK31 | - | ASK31N | - | - |
| K1i.. | DN 20...32 | Direct | ASK24 | ASK33 | - | ASK33N | - | - |
| K1f.. | DN 40...200 | Direct | ASK24 | ASK33 | - | ASK33N | - | - |
| VKF41.. | DN 40...125 | - | - | ASK33 | - | ASK33N | - | - |
| | DN 150 / DN 200 | - | - | ASK33 | ASK35 | ASK33N | - | ASK33N |
| VKF45.. | DN40...65 | - | - | - | ASK35 | - | ASK35N | ASK35N |
| | DN80...200 | - | - | - | - | - | - | ASK35N |

¹⁾ Replace with rotary actuators SQK34.., SQK84.. (data sheet N4508) or SQK33.00 (data sheet N4506).

²⁾ Replace with rotary actuators SQK33.00 + ASK32

Note

D Rotary actuators SAL.. are not suited for mounting sets ASK24, ASK25, ASK31, ASK32, ASK33, ASK35, ASK40 and ASK41.

2.7.3 Electrical accessories

Notes

- If an auxiliary switch is required, its switching point should be indicated on the plant schematic.
- For media below 0 °C the stem heating element ASZ6.6 keeps the valve free from freezing.
- For this case, do not insulate the actuator bracket and the valve stem, as air circulation must be ensured!
- **Non-observance of the above may result in accidents and fires!**
- **Do not touch the hot parts without prior protective measures to avoid burns.**



| Stroke actuators | | SQX.. | | | | SAX.. | |
|------------------|---|---------|---------|---------|---------|--------------------------|---------------|
| | | SQX31.. | SQX61.. | SQX32.. | SQX62.. | SAX31.. | SAX61.. |
| | | SQX81.. | - | SQX82.. | - | SAX81.. | - |
| ASZ6.5 | Stem heater | ASZ6.5 | ASZ6.5 | ASZ6.5 | ASZ6.5 | ASZ6.6 | ASZ6.6 |
| ASZ7.4 | 1 auxiliary switch, 1 potentiometer (1000 Ω) | ASZ7.4 | - | ASZ7.4 | - | ASC10.51 + ASZ7.5 | - |
| ASC9.4 | Double auxiliary switch | ASC9.4 | - | ASC9.4 | - | 2x ASC10.51 | - |
| ASC9.5 | Auxiliary switch | ASC9.5 | - | ASC9.5 | - | ASC10.51 | - |

| Rotary actuators | | SQL.. | | | | SAL.. | |
|------------------|---|---------|---------|---------|----------|--------------------------|--------------------------|
| | | SQL31.. | SQL32.. | SQL33.. | - | SAL31..T10 | - |
| | | - | - | SQL83.. | - | SAL81..T10 | - |
| | | - | - | - | SQL35.00 | - | SAL31.00T20 / T40 |
| | | - | - | - | SQL85.00 | - | SAL81.00T20 / T40 |
| ASZ7.4 | 1 auxiliary switch, 1 potentiometer (1000 Ω) | - | - | ASZ7.4 | ASZ7.4 | ASC10.51 + ASZ7.5 | ASC10.51 + ASZ7.5 |
| ASC9.4 | Double auxiliary switch | - | - | ASC9.4 | ASC9.4 | 2x ASC10.51 | 2x ASC10.51 |
| ASC9.5 | Auxiliary switch | - | - | ASC9.5 | ASC9.5 | ASC10.51 | ASC10.51 |
| ASZ8.4 | Potentiometer (220 Ω) | ASZ8.4 | ASZ8.4 | - | - | ¹⁾ | - |
| ASZ9.4 | Potentiometer (2800 Ω) | ASZ9.4 | ASZ9.4 | - | - | ¹⁾ | - |
| ASC1.4 | Auxiliary switch | ASC1.4 | ASC1.4 | - | - | ASC10.51 | - |



¹⁾ Used auxiliary switches or potentiometer (order accessories additionally were applicable):

- Check used functionality
- Check compatibility with controller

2.8 Spare parts

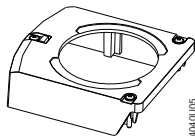
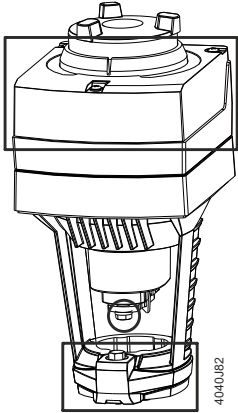

The following spare part sets are available:

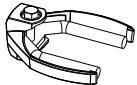
SAY.., SAX.., SAV..

| | | |
|-----------------------------------|---|---|
| Stock number 8000060843 | Housing cover  4040U05 |  4040U82 |
| | Screw (valve stem coupling)  4040U22 | |
| | U-bracket  4040U04 | |

Single components from the spare part sets are not available.

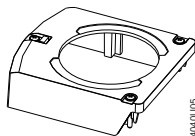
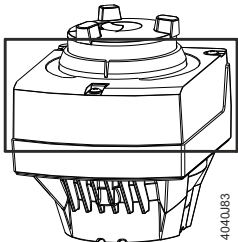
SAL..

| | | |
|-----------------------------------|---|---|
| Stock number 8000060844 | Housing cover  4040U05 |  4040U83 |
| | 2 adapters  4040U08 1 pc. 14 mm 1 pc. 11 mm | |
| | 4 screws  4040U20 2 pcs. M5 x 20 mm 2 pcs. M6 x 20 mm | |

Single components from the spare part sets are not available.

2.9 Sizing

2.9.1 Parallel operation of actuators

SA..31.. and SA..81..

3-position actuators must have one specific controller each, refer to "Connection diagrams" (page 85).

SA..61..

Up to 10 actuators can drive in parallel on a controller output with a rating of 1 mA. Modulating actuators have an input impedance of 100 kΩ.

SA..61../MO

The Modbus converter is designed for analog control on 0..10 V on the actuator side.

Note: Keep the setting of the analog signal on the actuator as is (switch 1 to "OFF"), adjustment is not allowed.

The actuators are factory-set to equal-percentage characteristic curve.

Note: The DIL switch (actuator-internal changeover of characteristic curve) must be set to "log" (switch 2 to "OFF").

2.9.2 Permissible cable lengths and wire cross-sectional areas

Cable lengths and wire cross-sectional areas depend on the following criteria of the actuators:

- Current draw
- Permissible voltage drop across the power supply lines

The control accuracy of the modulating actuators can be improved by using 4-wire connections, thus ensuring that voltage drops on G0 will not distort the positioning signal.

Note

When determining the cable length and the wire cross-sectional area, adherence to the permissible operating voltage tolerance at the actuator is of importance, in addition to the permissible voltage drop across the operating voltage and signal lines (see table below).

| Product no. | Operating voltage | Terminal | Max. permissible voltage drop |
|-------------|-------------------|-----------|-------------------------------|
| SA..31.. | AC 230 V | N, Y1, Y2 | 2% each (total of 4%) |
| SA..61.. | AC/DC 24 V | G0, G | 4% each (total of 8%) |
| | | G0, Y, U | 1% each (at DC 0...10 V) |
| SA..81.. | | G, Y1, Y2 | 4% each (total of 8%) |

The following criteria must be considered:

- With modulating control, the permissible positioning signal error must not exceed 1%, the reason being the voltage drop on the G0 wire.
- The voltage drop, caused by charging current peaks in the actuator's DC circuit, must not exceed 2 Vpp.
- If the G0 line is not correctly sized, load changes of the actuator due to changes of the DC voltage drop might lead to self-oscillations.
- The operating voltage drop at AC/DC 24 V may be a maximum of 8% (4% above the G0 wire).

Basic diagram – voltage drop across the power supply cables

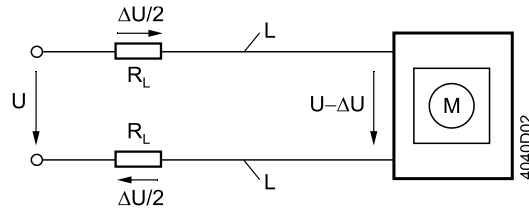

The following diagram can be used to determine the cable lengths and wire cross-sectional areas.

L/P-diagram for AC/DC 24 V

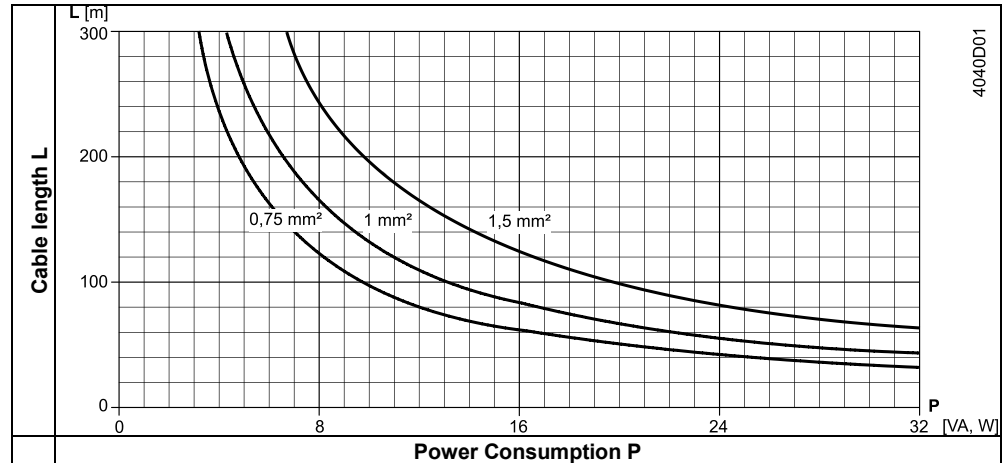

Permissible cable length **L** as a function of power **P** and cross-sectional area of wire as a parameter

Note

P is the decisive power consumption of all actuators connected in parallel. When operating on AC 24 V, power consumption is in VA; when operating on DC 24 V, in W.

Formulas for wire lengths

| Operating voltage | Permissible voltage drop / wire | Formula for wire length |
|-------------------|---------------------------------|---|
| AC 230 V | 2% of AC 230 V | $L = 46 \cdot \frac{1313 \cdot A}{P}$ [m] |
| AC/DC 24 V | 4% of AC 24 V | $L = \frac{1313 \cdot A}{P}$ [m] |
| | 1% of DC 10 V | $L = \frac{5.47 \cdot A}{I(DC)}$ [m] |

- A Cross-sectional area of wire in mm²
- L Permissible wire length in m
- P Power consumption in VA (AC) or W (DC) (see actuator's rating plate)
- I(DC) DC current part (in A) on G0 wire

2.10 Warranty

The engineering data specified in chapter "Equipment combinations" (page 15) are only guaranteed in connection with the Siemens valves listed.

Note

When using the actuators in connection with valves of other manufacture, correct functioning must be ensured by the user, and Siemens will assume no responsibility.

3 Handling

3.1 Mounting and installation

3.1.1 Mounting positions

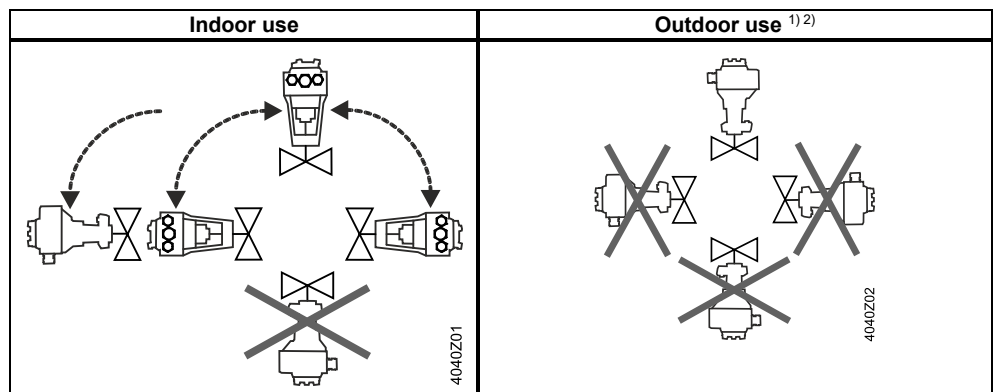

¹⁾ Only in connection with weather shield ASK39.1

²⁾ SA..61../MO are not suitable for outdoor applications.

3.1.2 Fitting stroke actuators to seat valves VVF.. / VXF.. or VVG.. / VVG..

First, observe "Mounting positions" (page 27).

| | |
|--|---|
| | <p>Caution! Risk of burns from hot surfaces! If you touch heated parts, you will get burns as result.</p> <ul style="list-style-type: none"> • Allow to cool parts. • Wear protective gloves. |
|--|---|

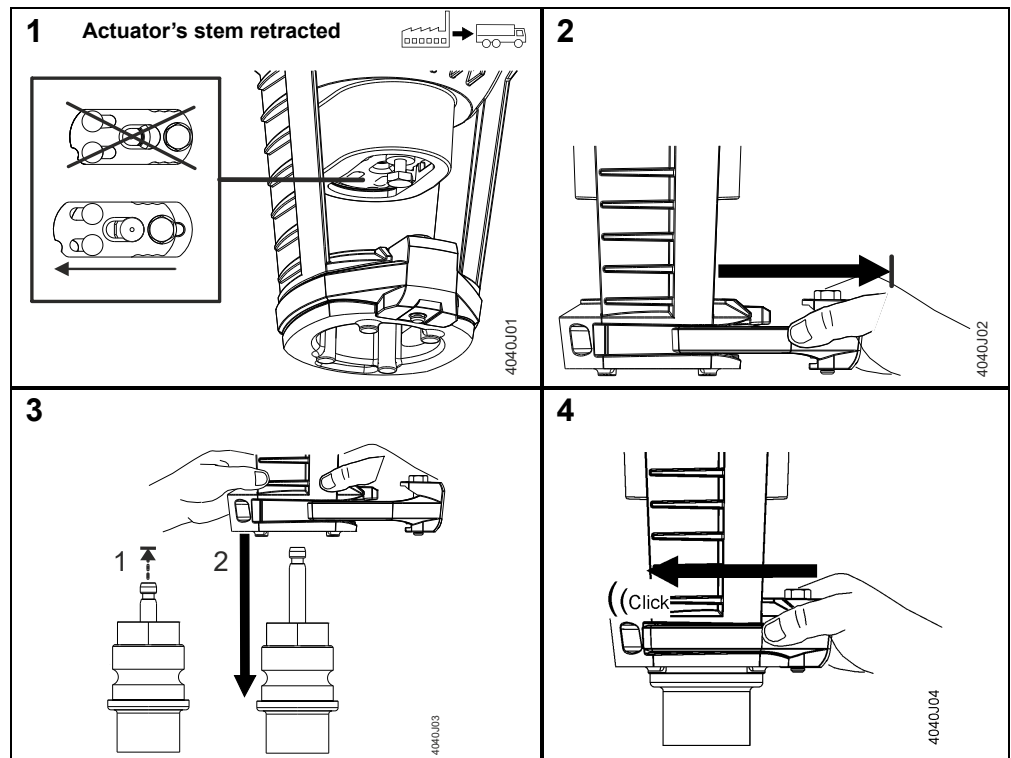

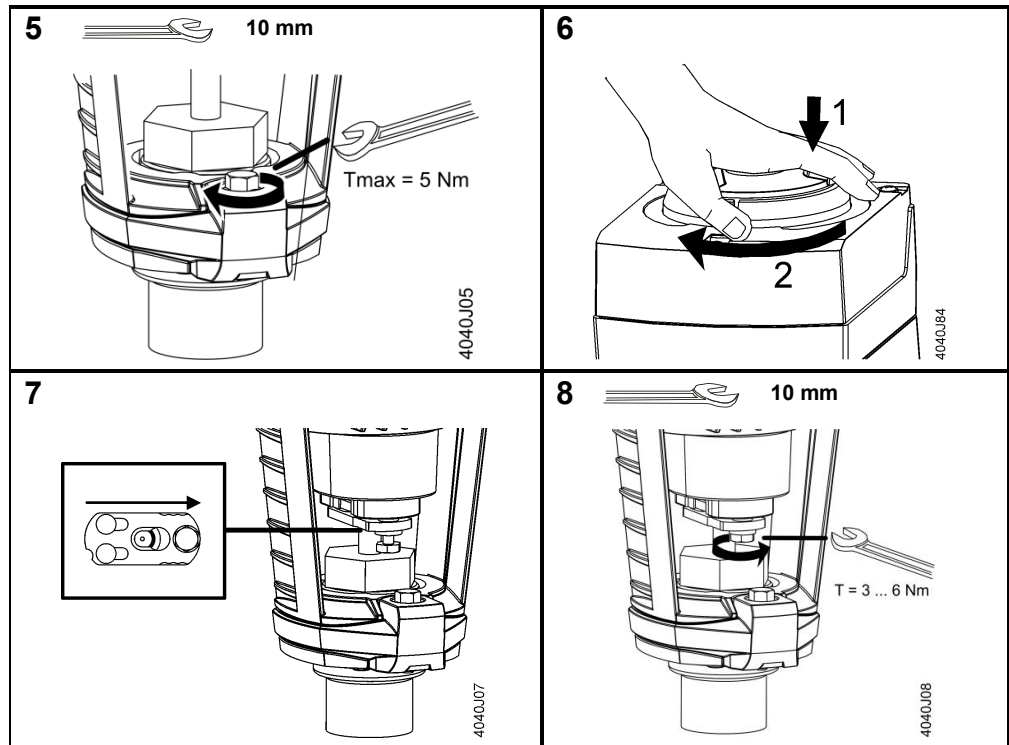

3.1.3 Avoid missalignment on V_G41 valves with fittings

| | |
|--|---|
| | Caution! |
| | Risk of burns from hot surfaces! If you touch heated parts, you will get burns as result. <ul style="list-style-type: none"> • Allow to cool parts. • Wear protective gloves. |

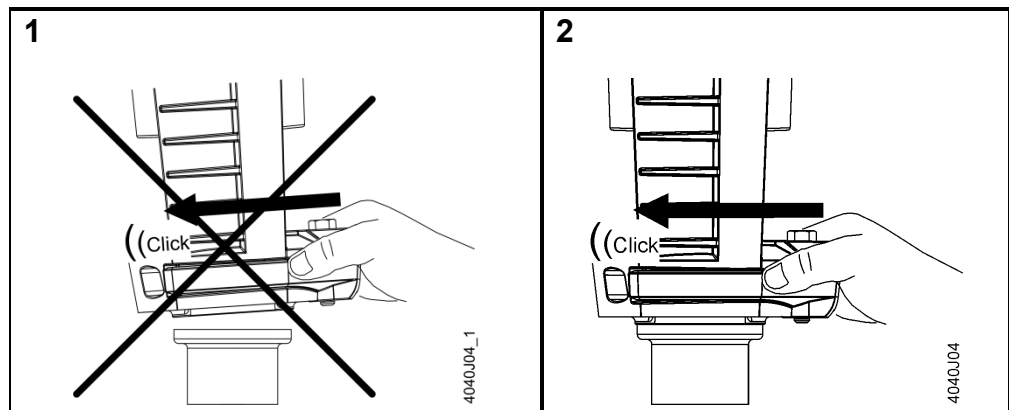

On threaded valves it's possible that the actuator is missaligned on the valve due to a collision with the fitting. If so, please take care for correct mounting, either by turning the actuator or by adjusting the fitting (e.g. use a second sealing to change fitting position).

3.1.4 Fitting rotary actuators to butterfly valves VKF41..

First, observe "Mounting positions" (page 27).

Mounting set ASK33N

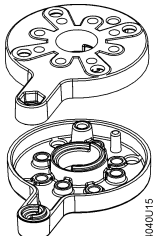
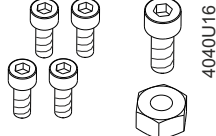
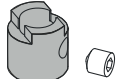
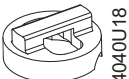
| Scope of delivery | | | |
|---|--|---|---|
| Mounting set (2 parts) | 5 screws | 1 adapter inc. fixing screw | 1 adapter |
|  | 4 pcs. M6 x 16 mm 1 pc. M5 x 20 incl. nut  |  |  |

Note

Actuators SAL.. are not compatible with mounting sets ASK31, ASK32, ASK33, ASK35, ASK40, and ASK41.

| | |
|---|---|
|  | <p>Caution!</p> <p>Risk of burns from hot surfaces!</p> <p>If you touch heated parts, you will get burns as result.</p> <ul style="list-style-type: none"> • Allow to cool parts. • Wear protective gloves. |
|---|---|

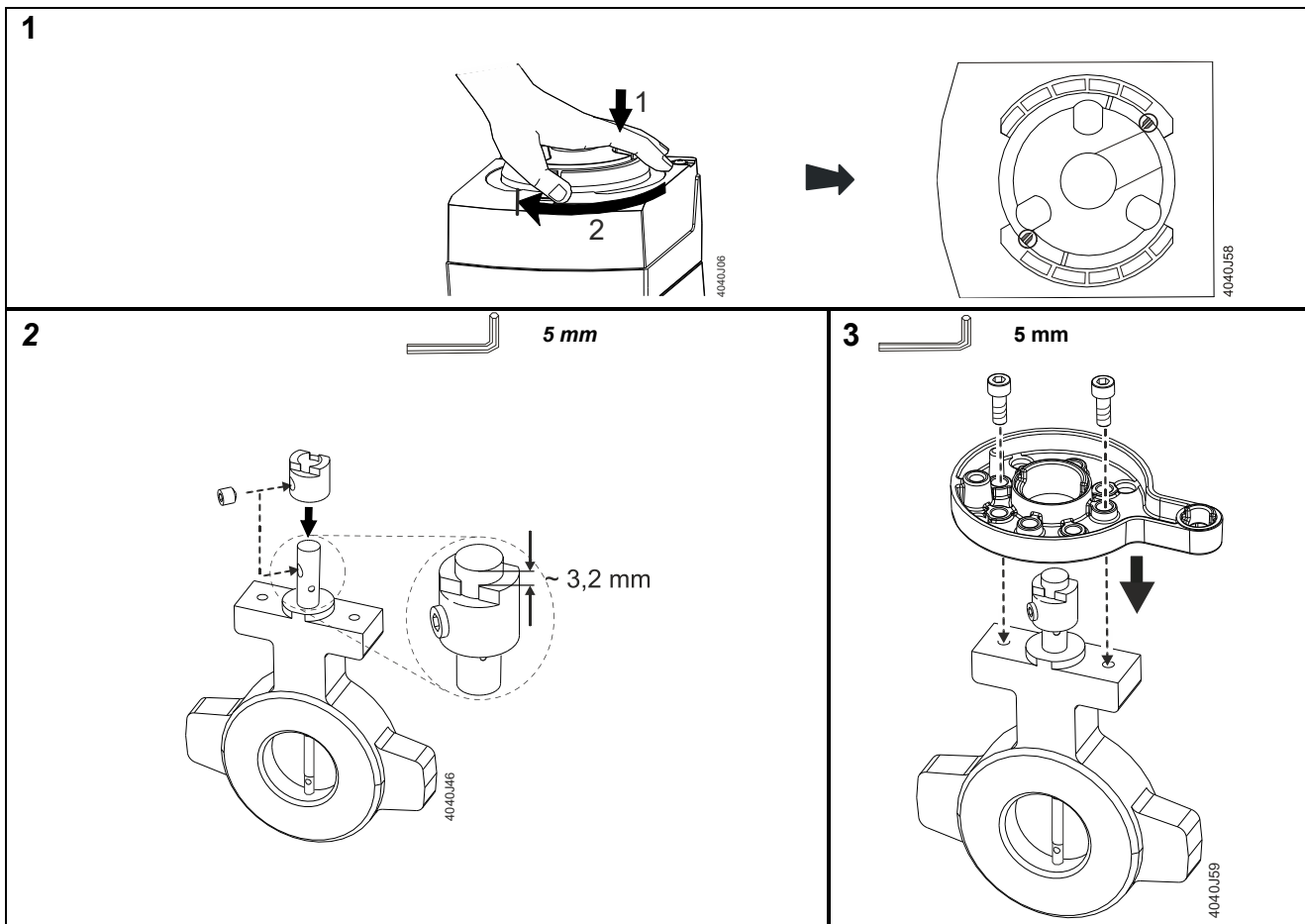

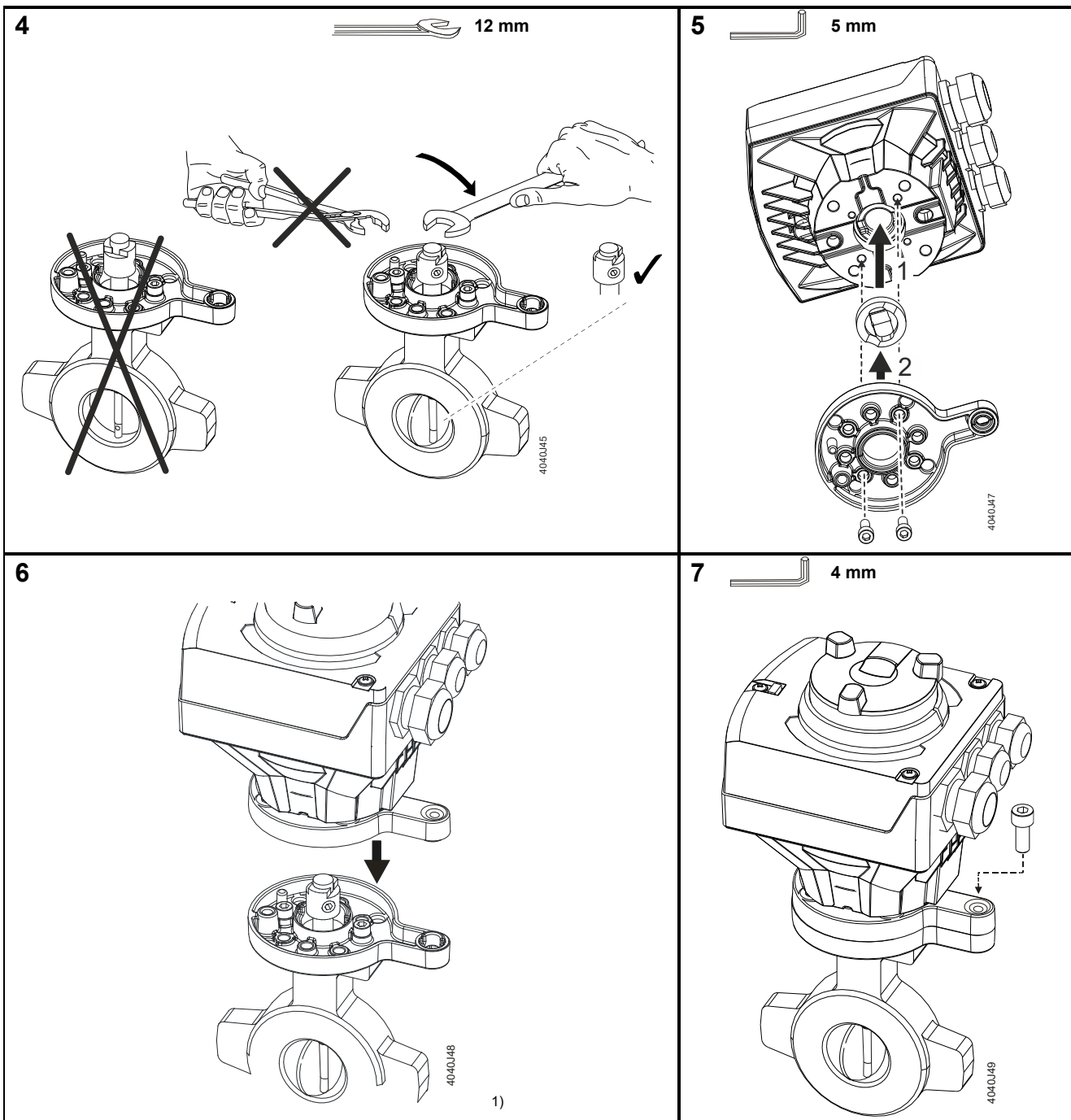



¹⁾ Angle position errors between actuator shaft and valve stem must be corrected via manual control (refer to "Manual adjuster" page 76).

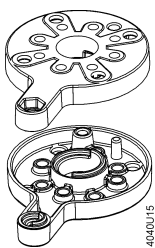
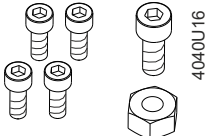

3.1.5 Fitting rotary actuators to slipper valves VBF21..

First, observe "Mounting positions" (page 27).

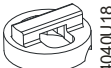
Mounting set ASK31N

| Scope of delivery | | | |
|---|---|---|---|
| Mounting set (2 parts) | 5 screws | 1 adapter incl. fixing screw | 1 adapter |
|  | 4 pcs. M6 x 16 mm 1 pc. M5 x 20 mm incl. nut  |  |  |

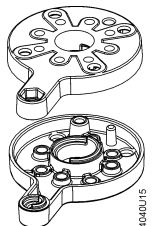
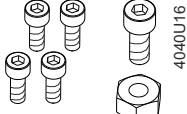
Mounting set ASK32N for VBF21.., DN 40...50

| | | |
|---|---|---|
| Mounting set (2 parts) | 5 screws | 1 adapter |
|  | 4 pcs. M6 x 16 mm 1 pc. M5 x 20 mm incl. nut  |  |

With VBF21.. (e.g. DN 125), the following steps must be performed prior to fitting the mounting set.

| | |
|---|--|
|  | <p>Caution! Risk of burns from hot surfaces!</p> <p>If you touch heated parts, you will get burns as result.</p> <ul style="list-style-type: none"> • Allow to cool parts. • Wear protective gloves. |
|---|--|

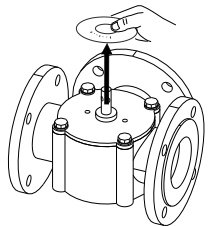
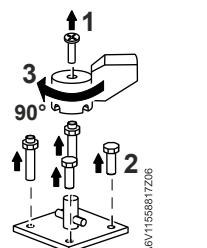
| | |
|---|---|
| <p>1</p>  | |
| <p>2a ASK31N</p>  | <p>2b ASK32N</p> <p>10 mm, 13 mm</p>  |

Opening
counterclockwise

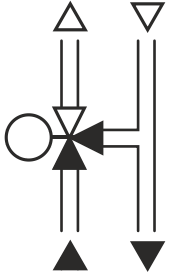

| | |
|---|---|
| <p>3.1a ASK31N</p> <p>4 mm, 5 mm 12 mm</p> | <p>3.1b ASK32N</p> <p>4 mm, 5 mm</p> |
| <p>3.2a ASK31N</p> <p>4 mm, 5 mm 12 mm</p> | <p>3.2b ASK32N</p> <p>4 mm, 5 mm</p> |

Opening clockwise

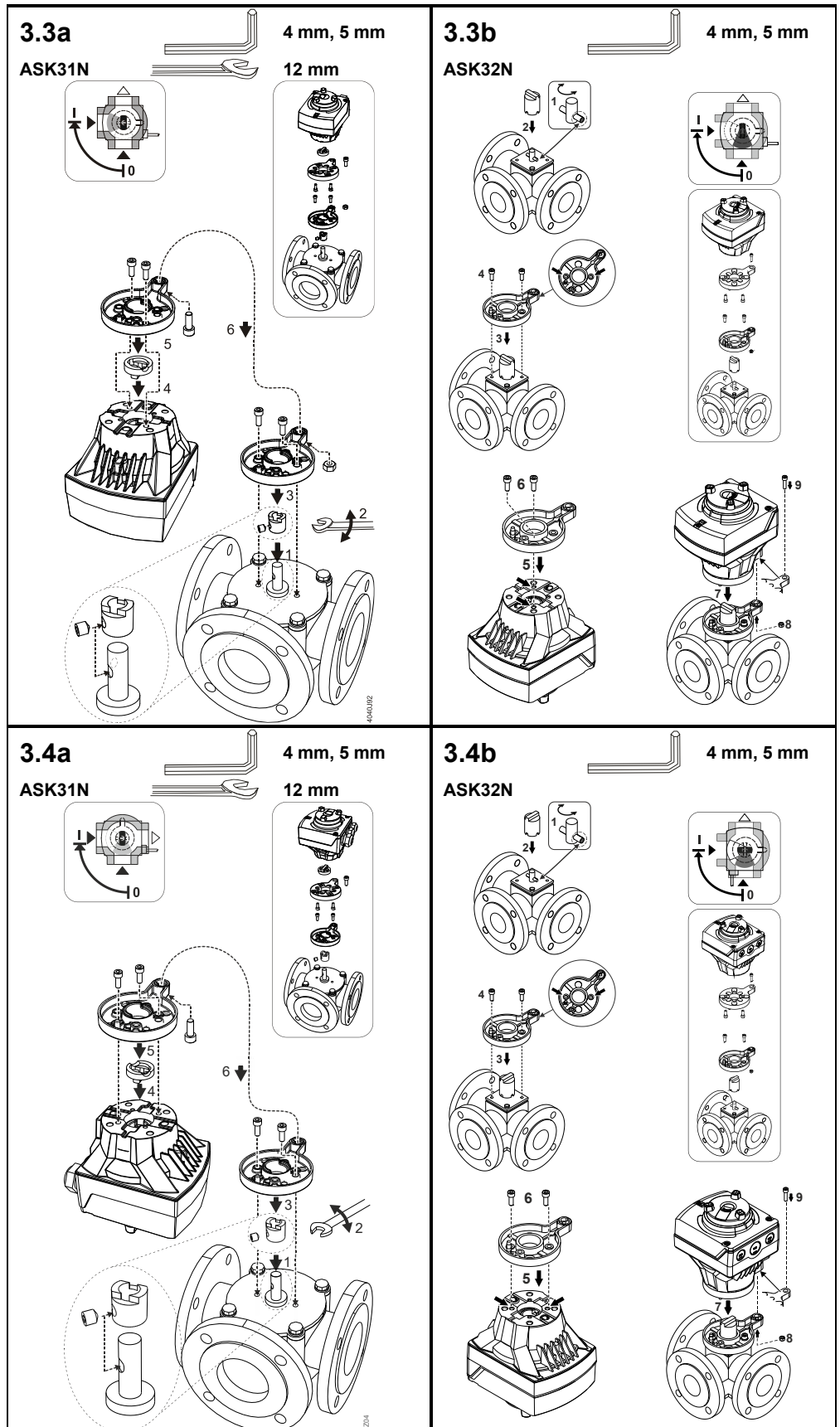
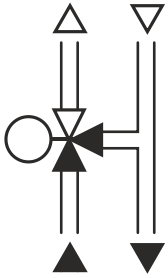

For further mounting positions of VBF 21.. and routing of the connection cables the rotary actuators and adapters must be mounted according to the sketches above.

3.1.6 Fitting rotary actuators to butterfly valves VKF46..

First, observe "Mounting positions" (page 27).

Standard scope of delivery
VKF46..

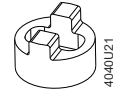
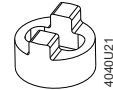
| Product no. | Scope of delivery | | |
|-------------|-------------------|---|---|
| | 2 screws | | 1 dapter |
| SAL..T20 | 2 pcs. M5 x 20 mm |  4040U20 | 1 pc. 11 mm  |
| SAL..T40 | 2 pcs. M6 x 20 mm | | 1 pc. 14 mm  |



Caution!

Risk of burns from hot surfaces!

If you touch heated parts, you will get burns as result.

- Allow to cool parts.
- Wear protective gloves.

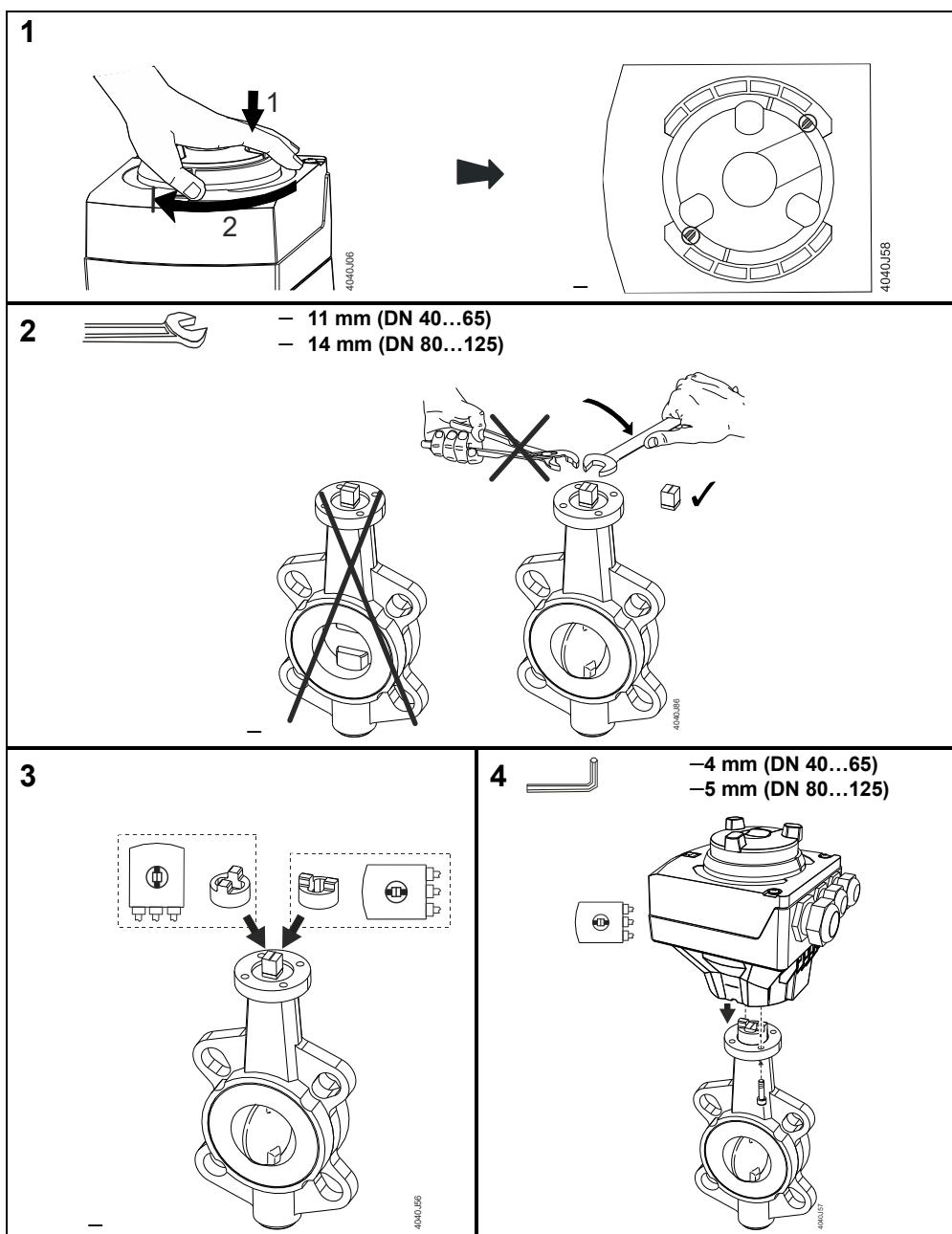

3.1.7 Fitting rotary actuators to butterfly valves VKF45..

First, observe "Mounting positions" (page 27).

Mounting set ASK35N

For VKF45..

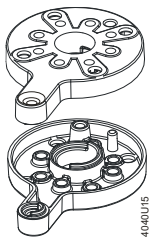
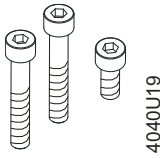
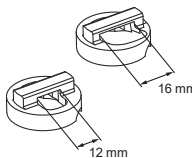
| Scope of delivery | | |
|---|---|---|
| Mounting set (2 parts) | 5 screws | 2 adapters |
|  | 2 pcs. M8 x 50 mm 1 pc. M5 x 20 mm incl. nut  | 1 pc. 12 mm 1 pc. 16 mm  |

Note

Actuators SAL.. are not suited for use with mounting sets ASK31, ASK32, ASK33, ASK35, ASK40, and ASK41.

| | |
|---|--|
|  | <p>Caution! Risk of burns from hot surfaces!</p> <p>If you touch heated parts, you will get burns as result.</p> <ul style="list-style-type: none"> • Allow to cool parts. • Wear protective gloves. |
|---|--|

1

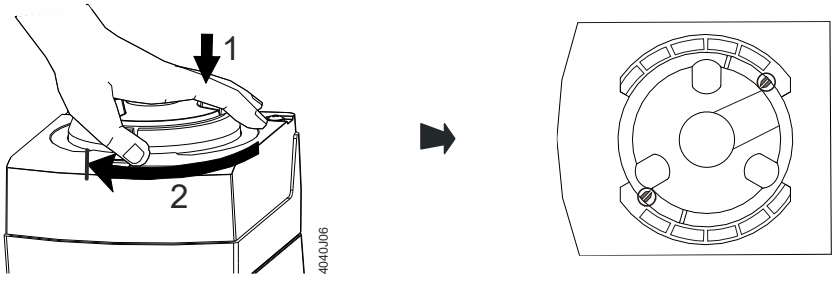

2

 12 mm (DN 40...125)
16 mm (DN 150 / 200)

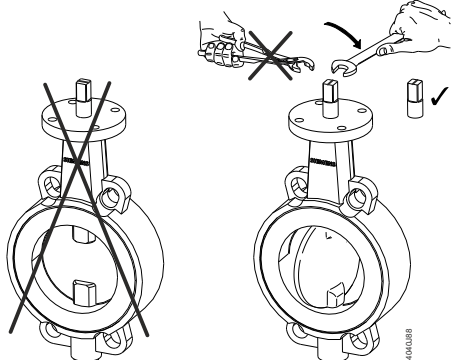

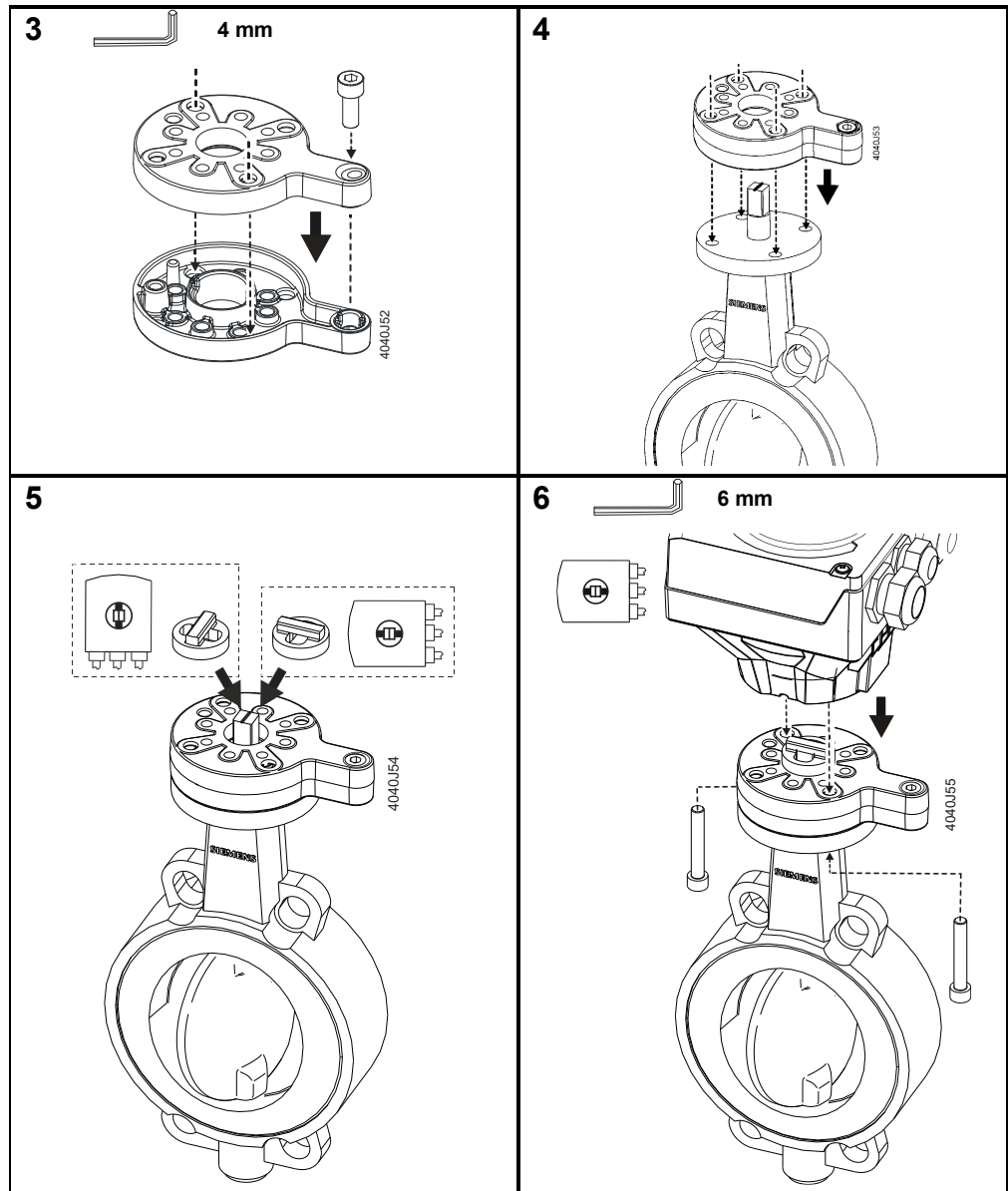





3.1.8 Fitting rotary actuators to butterfly valves VFL41..

First, observe "Mounting positions" (page 27).

Standard scope of delivery
VFL41..

| Product no. | Scope of delivery | | | |
|-------------|-------------------|--|-------------|--|
| | 2 screws | | 1 dapter | |
| SAL..T20 | 2 pcs. M5 x 20 mm |  4040U20 | 1 pc. 11 mm |  4040U41 |
| SAL..T40 | 2 pcs. M6 x 20 mm | | 1 pc. 14 mm |  4040U06 |

| | |
|---|---|
|  | <p>Caution! Risk of burns from hot surfaces! If you touch heated parts, you will get burns as result.</p> <ul style="list-style-type: none"> • Allow to cool parts. • Wear protective gloves. |
|---|---|

1

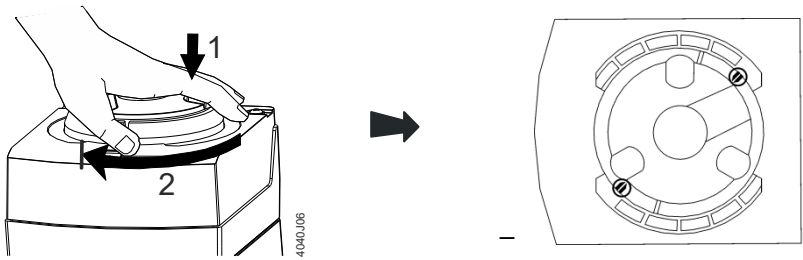

4040U06

2

– 11 mm (DN 40...65)
– 14 mm (DN 80...125)

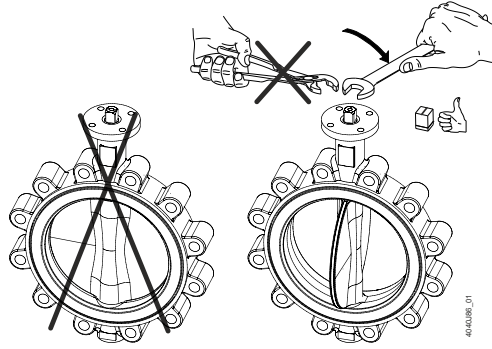

4040U06_01

3

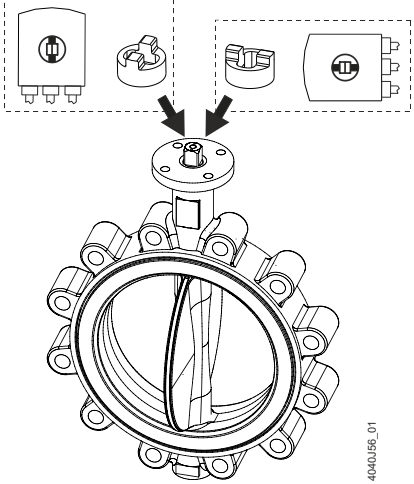

4040U06_01

4

–4 mm (DN 40...65)
–5 mm (DN 80...125)

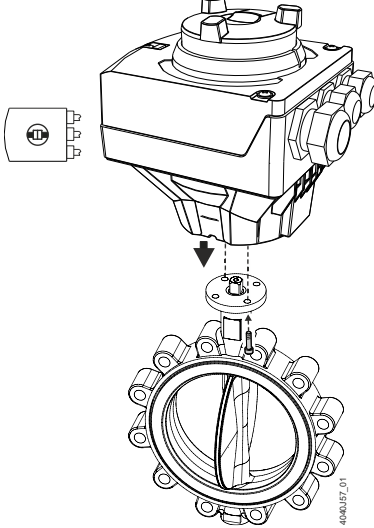



4040U07_01

3.1.9 Fitting rotary actuators to butterfly valves VFW41..

First, observe "Mounting positions" (page 27).

Standard scope of delivery
VFW41..

| Product no. | Scope of delivery | | | |
|-------------|-------------------|---|-------------|---|
| | 2 screws | | 1 dapter | |
| SAL..T20 | 2 pcs. M5 x 20 mm |  4040U20 | 1 pc. 11 mm |  4040U41 |
| SAL..T40 | 2 pcs. M6 x 20 mm | | 1 pc. 14 mm |  4040U06 |



Caution!

Risk of burns from hot surfaces!

If you touch heated parts, you will get burns as result.

- Allow to cool parts.
- Wear protective gloves.

1

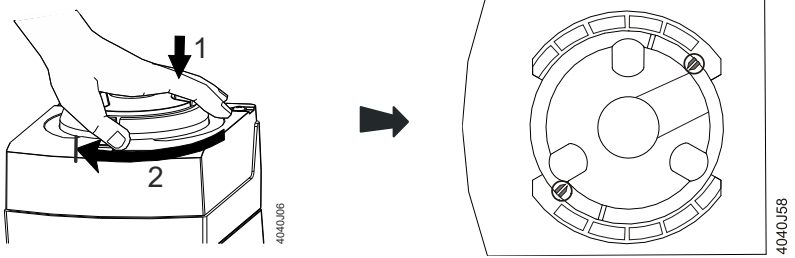

2

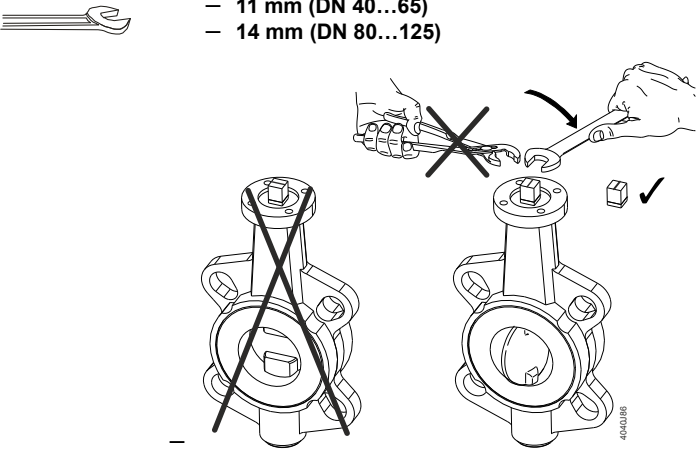

— 11 mm (DN 40...65)
— 14 mm (DN 80...125)

3

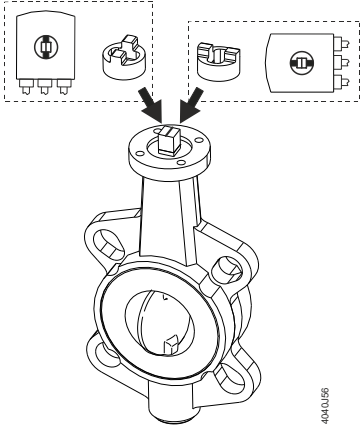

4

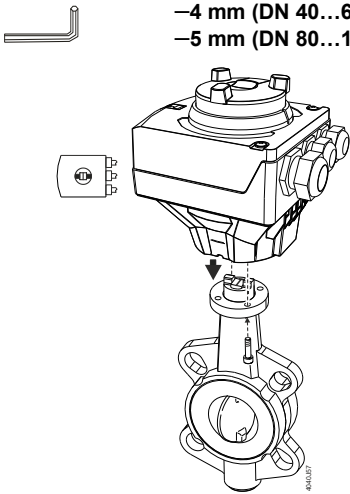



— 4 mm (DN 40...65)
— 5 mm (DN 80...125)

3.1.10 Fitting rotary actuators to butterfly valves VFW41U..

First, observe "Mounting positions" (page 27).

Standard scope of delivery
VFW41U..

| Product no. | Scope of delivery | | | |
|--------------|-------------------|---|-------------|---|
| | 2 screws | | 1 dapter | |
| SAL..T10/F05 | 2 pcs. M6 x 20 mm |  4040U20 | 1 pc. 14 mm |  4040U06 |

| | |
|---|---|
|  | Caution! |
| | Risk of burns from hot surfaces! If you touch heated parts, you will get burns as result. <ul style="list-style-type: none"> • Allow to cool parts. • Wear protective gloves. |

1

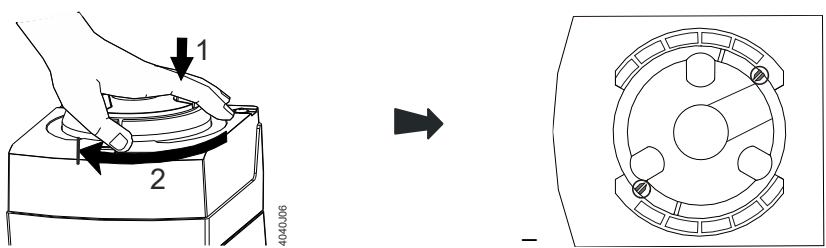

2  – 14 mm (DN 40...125)

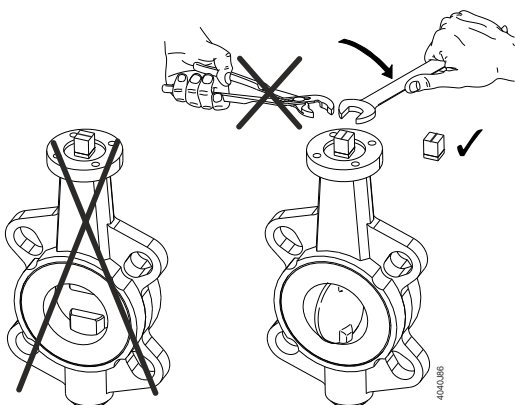

3

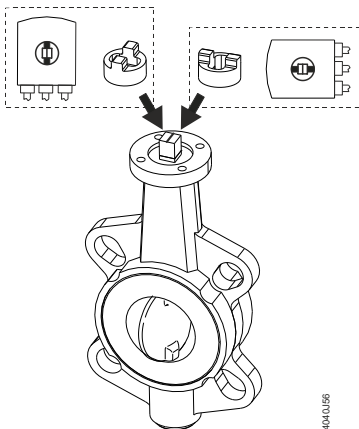

4  – 5 mm (DN 40...125)

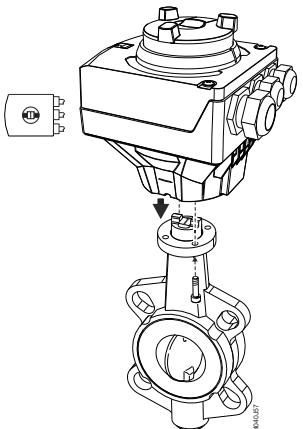

3.1.11 Fitting accessories

Special notes on mounting

SA..31..

Before fitting the accessory items shown below, the following steps must be performed:

| | |
|---|---|
|  | Danger! |
| | Danger to life from electrical current! There is an immediate risk of fatal injury in case of contact with live parts of SA..31... • Disconnect actuator from power. |

1. Actuator is mechanically connected to a Siemens valve.
2. Observe compatibility and choice of combinations. Refer to "Accessories" (page 21).
3. Disconnect actuator from power.
4. Only required with actuators without fail safe function: Using the manual adjuster, drive the actuator's stem to the fully retracted position and fix the coupling. See "Manual operation" and "Fixing coupling" (page 76).
5. When mounting two different accessories watch out for correct plug-in space A or B (see below).
6. To fit an auxiliary switch, potentiometer or function module, the housing cover must be removed.

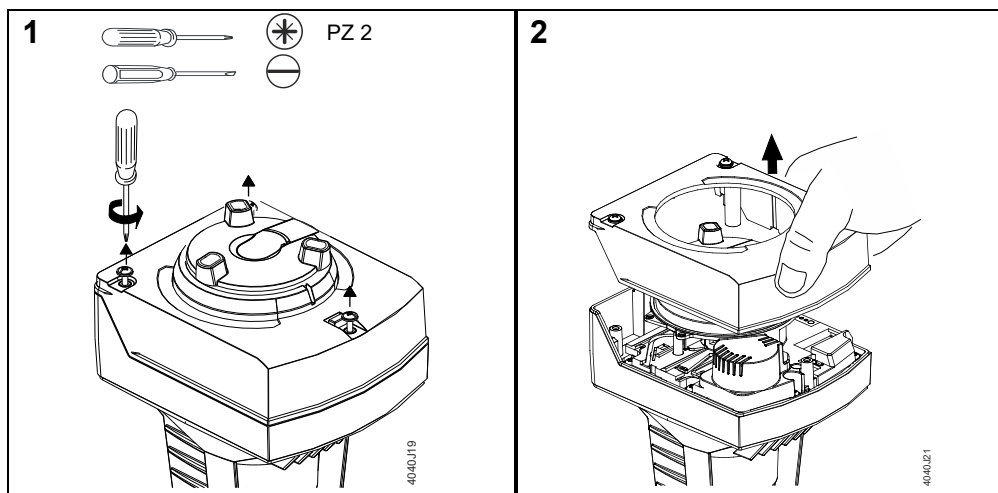

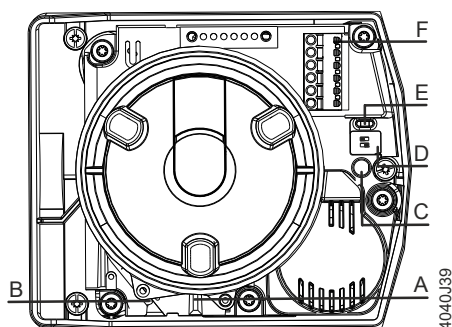

Interior view of setting elements and plug-in spaces

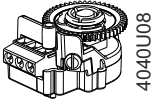

| | |
|----------|---|
| | Plug-in space for... |
| A | <ul style="list-style-type: none"> • Potentiometer ASZ7.5, or • Auxiliary switch ASC10.51 |
| B | Plug-in space for... <ul style="list-style-type: none"> • Function module AZX61.1 , or • Auxiliary switch ASC10.51 |
| C | LED |
| D | DIL switches |
| E | Calibration slot |
| F | Connection terminals |

**Potentiometer
ASZ7.5**

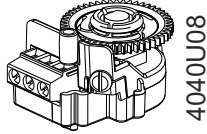

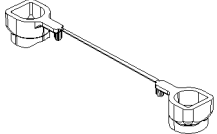
| Scope of delivery | | |
|---|---|---|
| 1 potentiometer ASZ7.5 | 1 screw | 2 screw covers |
|  4040U08 | 1 pc.  4040J26 |  4040U29 |



First, observe "Special notes on mounting" (page 40).
Also observe "Notes on ASZ7.5" (page 21).

| | |
|---|---|
|  | Danger! |
| | Danger to life from electrical current! If a live wire gets in contact with the screws the whole actuator housing is a live. • Fit the screw covers first. |

Plug-in space A

1

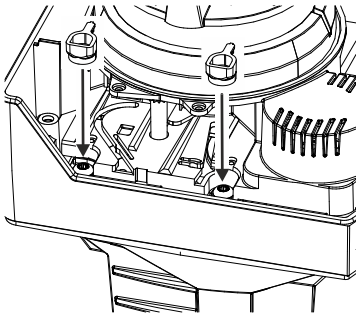

4040J61

2

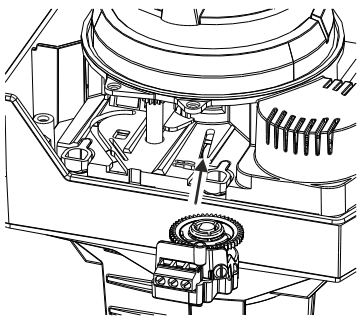

4040J26

3

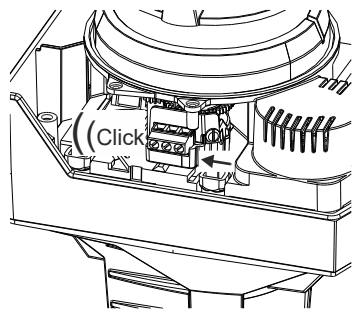

4040J27

4

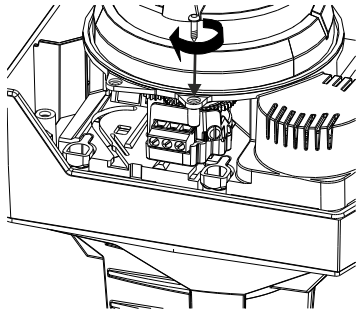

No.: 1
4040J63

5

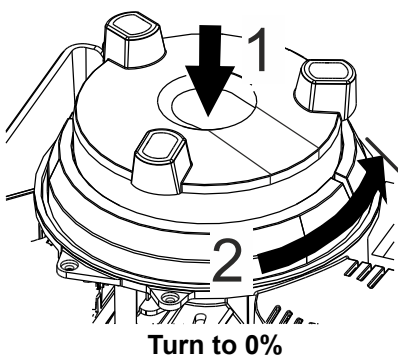

Turn to 0%

4040J72

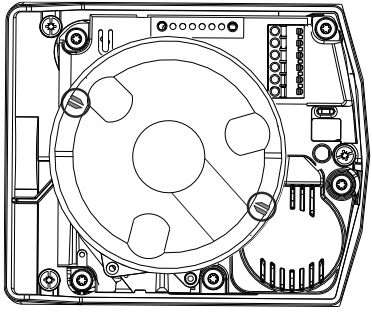

4040J73

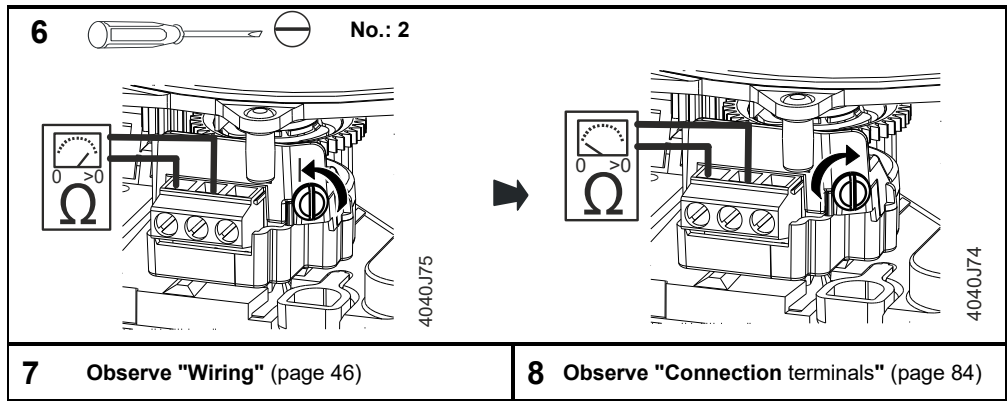

**Function module
AZX61.1**

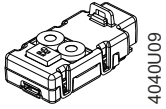

4040J09

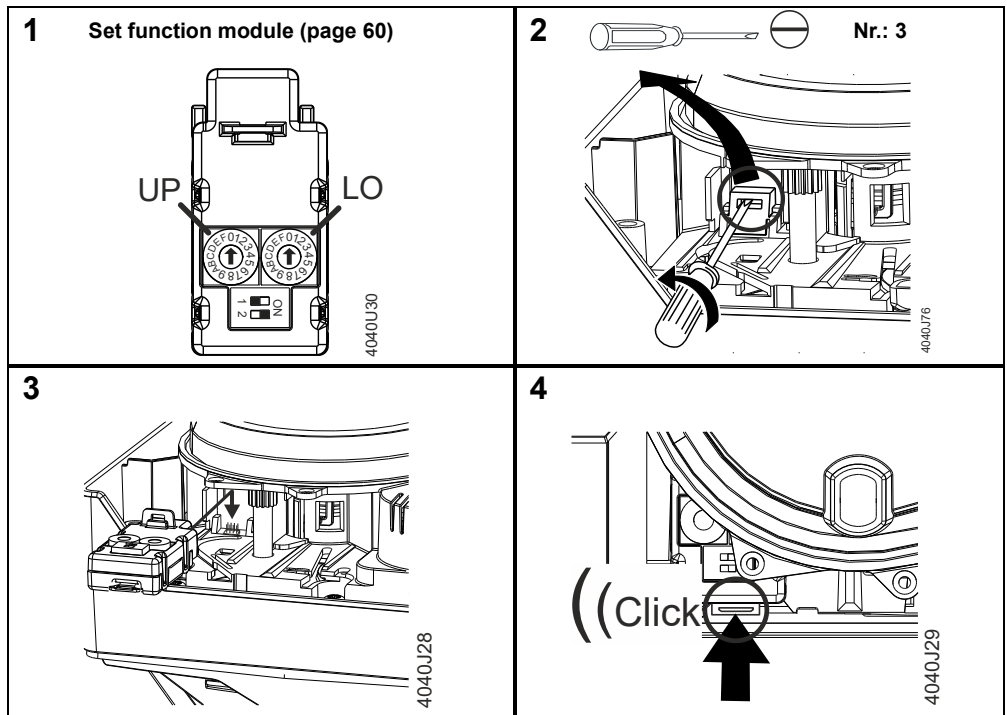

Plug-in space B

First, observe "Special notes on mounting" (page 40).

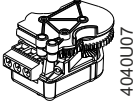

**Auxiliary switch
ASC10.51**

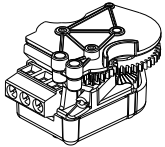

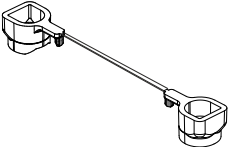
| Scope of delivery | | |
|---|---|---|
| 1 auxiliary switch ASC10.51 | 1 screw | 2 screw covers |
|  4040U07 | 1 pc.  4040J28 |  4040U29 |



First, observe "Special notes on mounting" (page 40).

| | |
|---|---|
|  | Danger! |
| | Danger to life from electrical current! If a live wire gets in contact with the screws the whole actuator housing is a live. • Fit the screw covers first. |

Plug-in space A

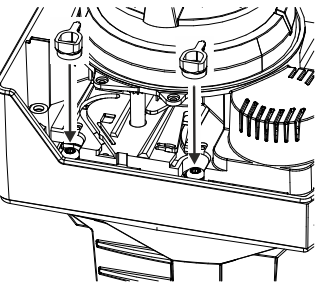
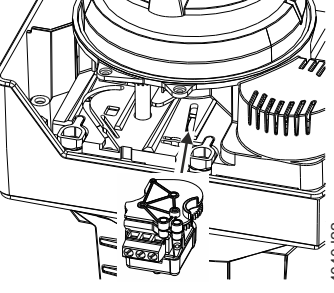
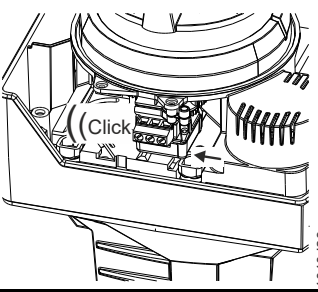
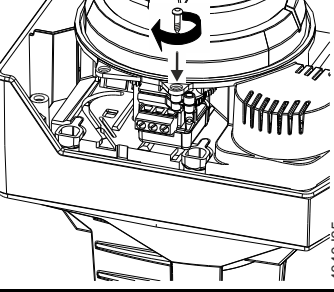
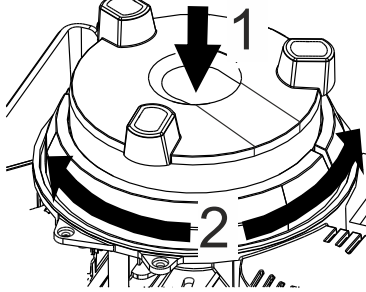
| | | | |
|----------|--|----------|---|
| 1 |  | 2 |  |
| 3 |  | 4 |  |
| 5 | Adjust switch position (refer also to "Manual operation" page 76) | | |
| |  | | |

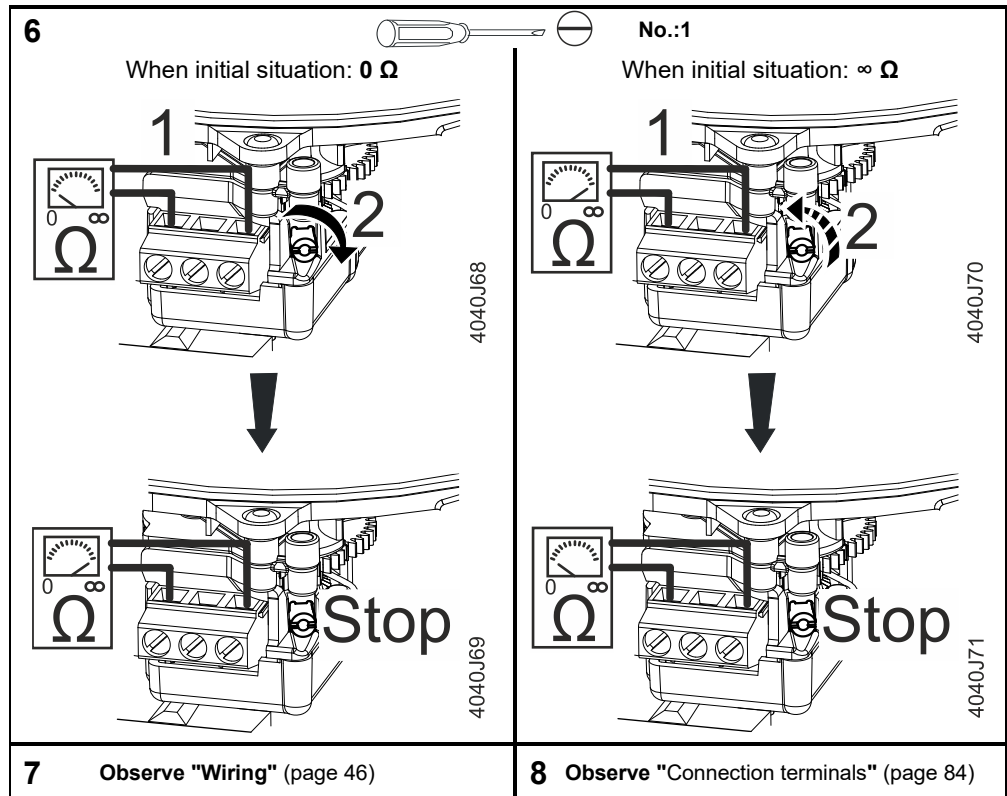

First, observe "Special notes on mounting" (page 40).

| | |
|--|--|
| | <p>Danger! Danger to life from electrical current! If a live wire gets in contact with the screws the whole actuator housing is a live. • Fit the screw covers first.</p> |
|--|--|

Plug-in space B

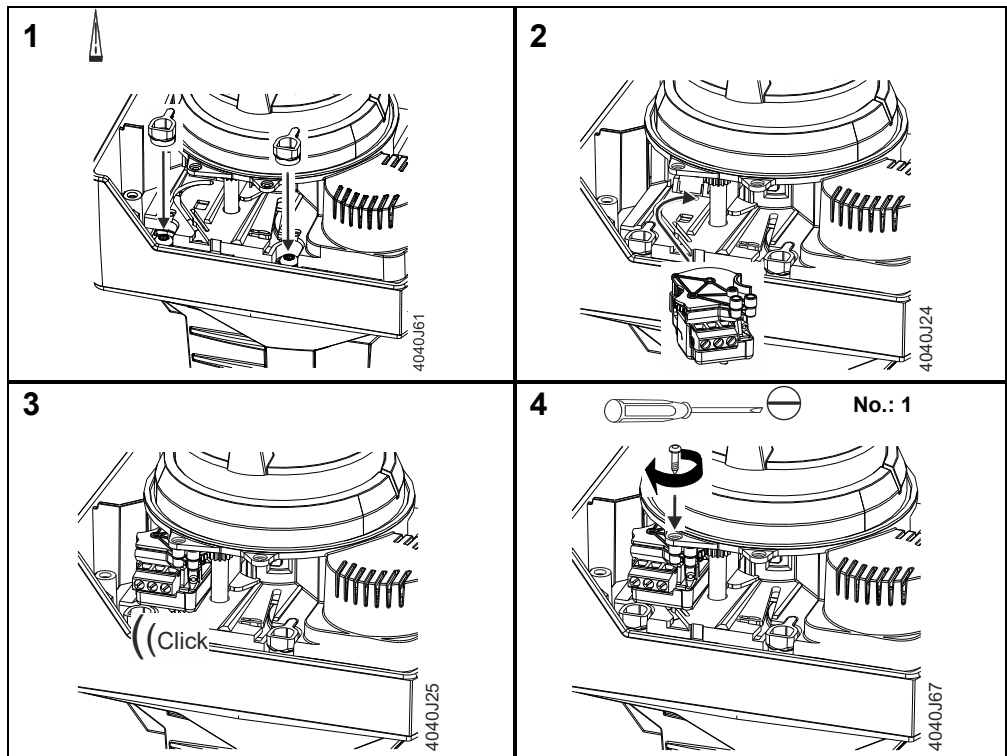

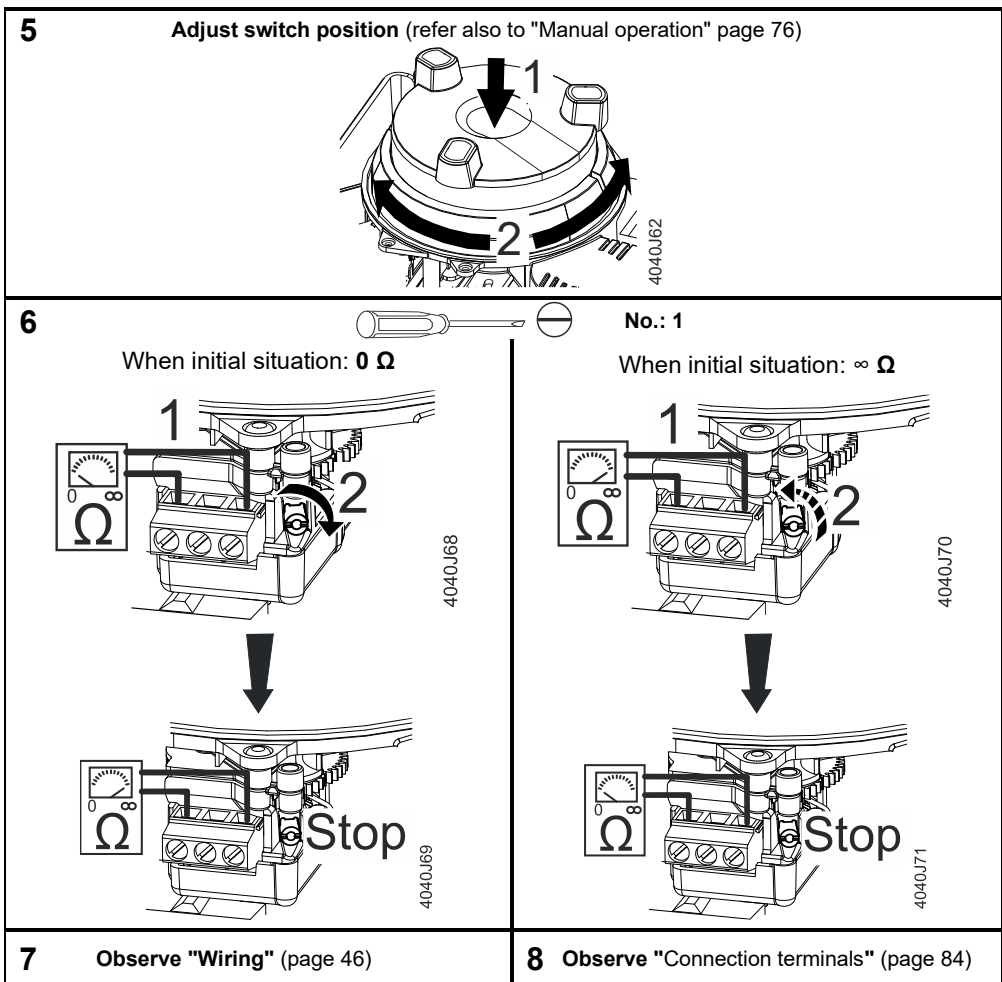

Stem heating element ASZ6.6

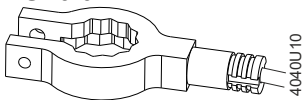

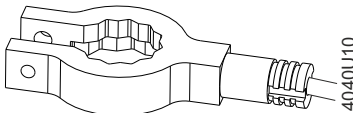
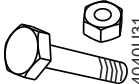
| Scope of delivery | |
|---|--|
| 1 stem heating element ASZ6.6 | 1 screw |
|  4040U10 | 1 pc. M4 x 30 incl. nut  4040U31 |

When fitting the stem heating element, stroke actuator and valve must be assembled. The stem heating element is powered separately. First, observe "Special notes on mounting" (page 40).

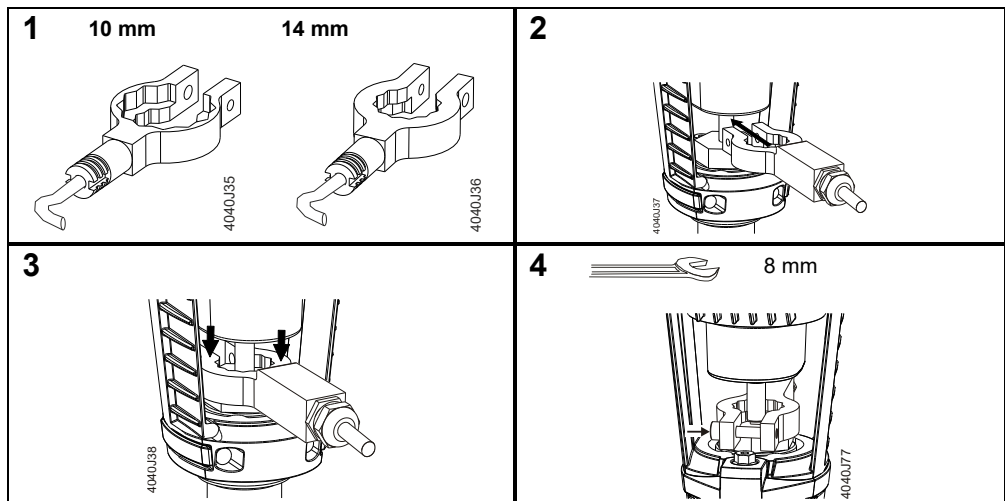

**Weather shield
ASK39.1**

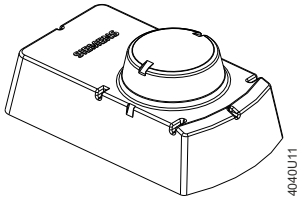

First, observe "Special notes on mounting" (page 40).

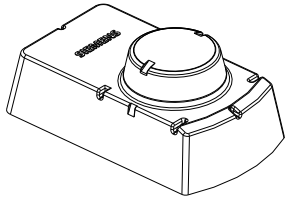
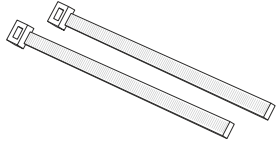
| Scope of delivery | |
|---|---|
| Weather shield ASK39.1 | 2 UV-proof cable ties |
|  |  |

Notes

- To protect the actuator when used outdoors, the weather shield must always be fitted.
- If fitted several times, 2 UV-proof cable ties (800 x 4 mm) must be used.
- The manual adjuster cannot be used when the weather shield is mounted.
- SA..61../MO are not suitable for outdoor applications.

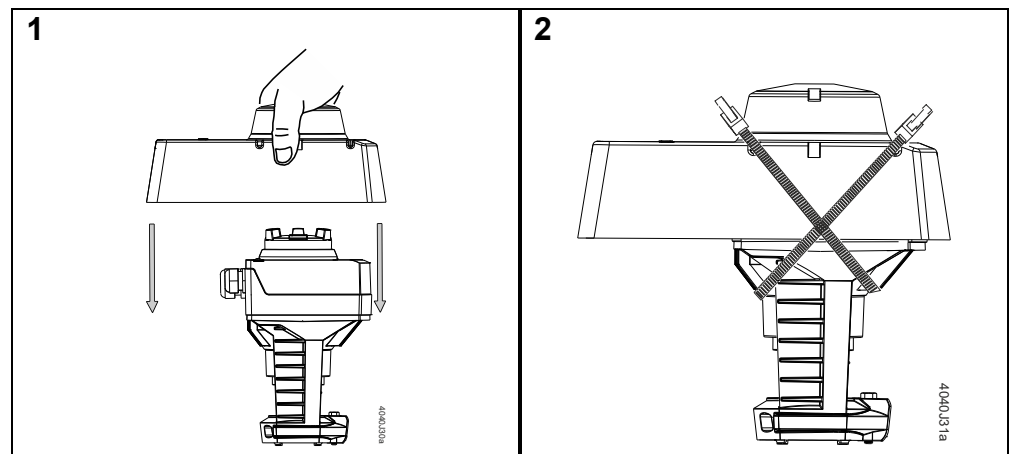

3.1.12 Wiring (installation)

Conduct the electrical connections in accordance with local regulations on electrical installations as well as the "Connection diagrams" on page 84.

Preparation of wire endings

The cable endings must be prepared before as follows.

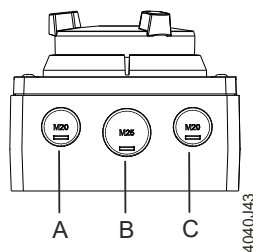
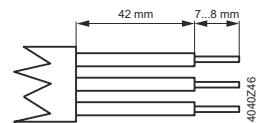

| | | | |
|----------|---------------------|---------------------------------------|------------------------|
| A | EU: M20 US: 1/2" | Standard | Connection actuator |
| B | EU: M25 US: 1/2" | Ground cable for outdoor installation | |
| C | EU: M20 US: 1/2" | | Connection accessories |

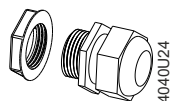
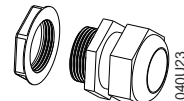
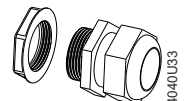
| Cable glands (not contained in scope of delivery) | | |
|---|--|--|
| Metric M20 | Metric M25 | Inch thread 1/2" |
|  4040J24 |  4040J23 |  4040J33 |

Prior to installation, the following preconditions must be satisfied:

- Actuator is mechanically connected to a Siemens valve.
- Housing cover is removed (step 6 "Special notes on mounting", page 40).

Communicating actuators



Device contains fixed connecting cable. Left cable duct used (A).

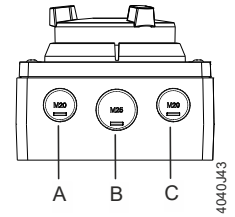

Actuator

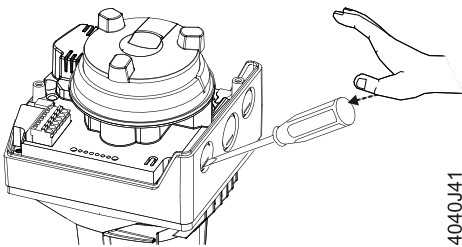
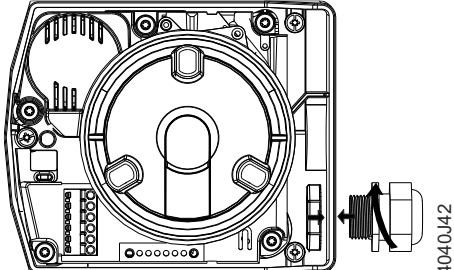
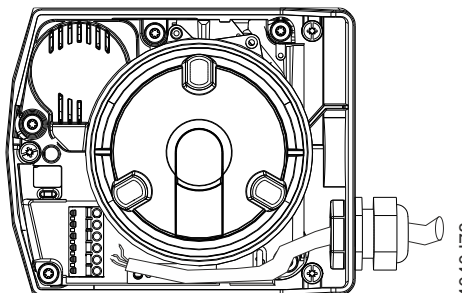
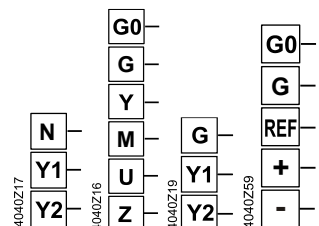
| | |
|--|--|
| <p>1  No.: 4</p>  <p>4040J41</p> | <p>2</p>  <p>4040J42</p> |
| <p>3</p>  <p>4040J78</p> | <p>4 Observe "Connection terminals" (page 84)</p>  |

**Auxiliary switch
ASC10.51**

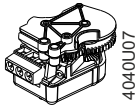

and

**Potentiometer
ASZ7.5**

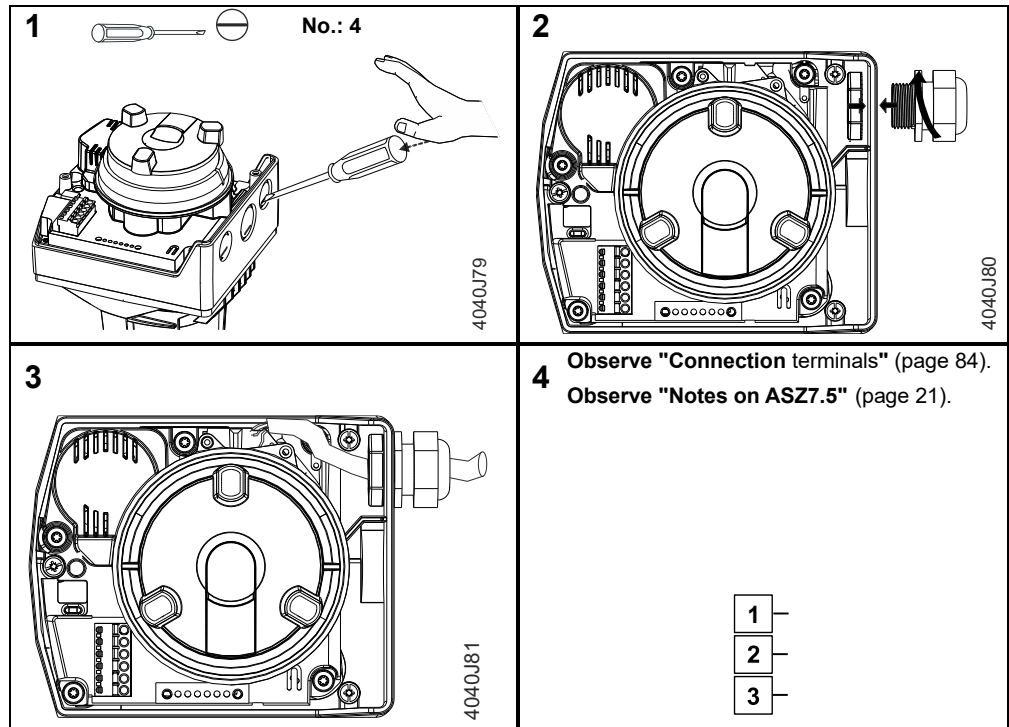
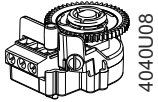

3.2 Commissioning and operation

3.2.1 Function check and Calibration

Mechanically

Before making the function check, the following preconditions must be satisfied:

- Environmental conditions specified in chapter "Technical data" (page 80)
- Actuator is mechanically connected to a Siemens valve
- **Actuator is in "Manual operation" mode** (page 76).

The actuator can be operated with the help of the "Manual adjuster" (see page 76).

| Manual adjuster | Stroke actuator | Rotary actuator | Control path valve A→AB | Bypass valve B → AB |
|--|--------------------------|--|-------------------------|---------------------|
| Turning in clockwise direction | Actuator's stem extends | Actuator's spindle turns in clockwise direction | Opening | Closing |
| Turning in counter-clockwise direction | Actuator's stem retracts | Actuator's spindle turns in counterclockwise direction | Closing | Opening |

Notes

- Ensure that the actuator's and valve's stem, or actuator's and valve's spindle are securely connected in all positions.
- If the actuator is forced to travel beyond its end positions, overload protection responds.
- Observe information given in chapter "Acting direction and flow characteristic" on page 63.

Electrically

Before making the function check, the following preconditions must be satisfied:

- Environmental conditions specified in chapter "Technical data" (page 80).
- Actuator is mechanically connected to a Siemens valve.
- **Actuator is in "Automatic" mode** (page 76).

Actuator and, if required, accessories are correctly fitted and connected. Also refer to "Connection Terminals" (page 84)

- Power is applied.

SA..61..

Calibration is required with modulating actuators and SA..61.. before the function check.

General notes on calibration

Before making the calibration, the following preconditions must be satisfied:

- A description of the calibration function is given in chapter "Calibration" (page 65 for non-Modbus actuators, page 70 for Modbus actuators).
- Housing cover is removed (step 6 "Special notes on mounting", page 40).

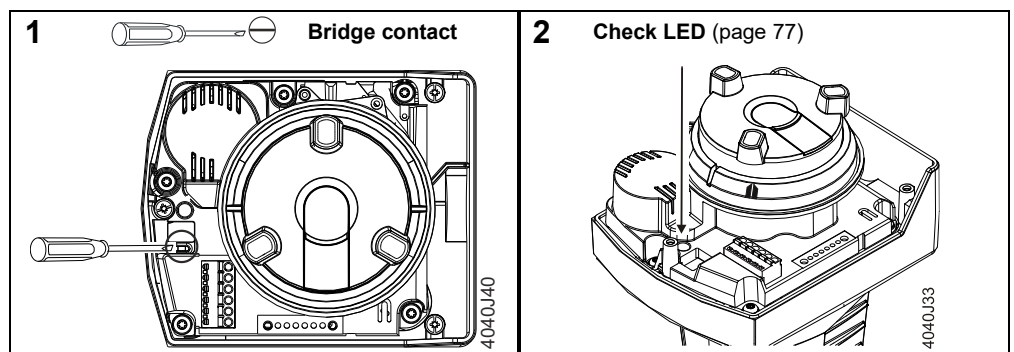

If required, calibration can be repeated any number of times.

Make the function check for modulating actuators after the calibration with a point test according to the following table:

SAX61.03/03U, SAV61.00/00U and SAL61..

| Connection terminals | Stroke actuator | | Rotary actuator | Control path valve A→AB | Bypass valve B → AB | Position feedback U | |
|-----------------------|--------------------------------|--------------------------------|---|-------------------------|---------------------|---------------------|-------------------|
| | log ¹⁾ | lin ¹⁾ | | | | log ¹⁾ | lin ¹⁾ |
| Y□ 6 V□ 13,6 mA | Actuator's stem extends (60%) | Actuator's stem extends (82%) | Actuator's spindle turns in clockwise direction (60 %) | Opening | Closing | 6 V | 8,2 V |
| Y 5 V□ 12 mA | Actuator's stem retracts (50%) | Actuator's stem retracts (75%) | Actuator's spindle turns in counterclockwise direction (50 %) | Closing | Opening | 5 V | 7,5 V |
| Z connected to G | Actuator's stem extends | | Actuator's spindle turns in clockwise direction | Opening | Closing | 10 V | |
| Z connected to G0 | Actuator's stem retracts | | Actuator's spindle turns in counterclockwise direction | Closing | Opening | 0 V | |

¹⁾ SAX61.03.. and SAV61.00.. factory setting **log**, SAL61.. factory setting **lin**

SAY61P., SAX61P03., SAV61P00...

| Connection terminals | Stroke actuator | | Rotary actuator | Control path valve A→AB | Bypass valve B → AB | Position feedback U | |
|-----------------------|--------------------------------|--------------------------------|-----------------|-------------------------|---------------------|---------------------|-------------------|
| | log ¹⁾ | lin ¹⁾ | | | | log ¹⁾ | lin ¹⁾ |
| Y□ 6 V□ 13,6 mA | Actuator's stem retracts (30%) | Actuator's stem retracts (60%) | - | Opening | Closing | 2.95 V | 6 V |
| Y 5 V□ 12 mA | Actuator's stem extends (23%) | Actuator's stem extends (50%) | - | Closing | Opening | 2.3 V | 5 V |
| Z connected to G | Actuator's stem retracts | | - | Opening | Closing | 10 V | |
| Z connected to G0 | Actuator's stem extends | | - | Closing | Opening | 0 V | |

¹⁾ SAY61P., SAX61P., SAV61P.. factory setting **log**

Make the function check for 3-position actuators according to the following table:

| Connection terminals | Stroke actuator | Rotary actuator | Control path valve A→AB | Bypass valve B → AB |
|-------------------------|--|---|-------------------------|---------------------|
| Voltage at Y1 | Actuator's stem extends ¹⁾ | Actuator's spindle turns in clockwise direction | Opening | Closing |
| Voltage at Y2 | Actuator's stem retracts ¹⁾ | Actuator's spindle turns in counter-clockwise direction | Closing | Opening |
| No voltage at Y1 and Y2 | Actuator's stem maintains the position | Actuator's spindle maintains the position | Maintains the position | |

¹⁾ The opposite is true for SA...1P..

Notes

- If function module AZX61.1 is used, observe information given in chapter "Changeover of acting direction" (page 61).
- Observe information given in chapter "Acting direction and flow characteristic" on page 63.

Auxiliary switch
ASC10.51

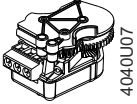

Make the function check for mounted auxiliary switches according to the following table – example switching point at 25% position:

| Connection terminals | | Stroke actuator | Rotary actuator | Terminal S1 – S3 | Terminal S1 – S2 |
|--|------------------------------------|--|---|------------------|------------------|
| Voltage at Y2 | Y = 0 V | Actuator's stem retracts (until end position is reached) | Actuator's spindle turns in counter-clockwise direction (until end position is reached) | - | - |
| No voltage at Y1 und Y2 | Y = 0 V | Actuator's stem maintains the position | Actuator's spindle maintains the position | | |
| Voltage at Y1 for desired valve position % + 2% x positioning time Example: SAX31.00 = 27% x 120 sec = 32.5 sec | Valve position % + 2% Y = 2.7 V | Actuator's stem extends to desired position (27%) | Actuator's spindle turns in clockwise direction to desired position (27%) | | |
| Check switching point with voltmeter | | Actuator's stem maintains the position | Actuator's spindle maintains the position | - | - |

Potentiometer ASZ7.5

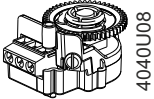

Make the function check for mounted potentiometer according to the following table (Example values for ASZ7.5):
First, observe "Notes on ASZ7.5" (page 21).

| Connection terminals | | Stroke actuator | Rotary actuator | Terminal P1 – P2 | Terminal P2 – P3 |
|---|--|--|---|------------------|------------------|
| Voltage at Y2 | | Actuator's stem retracts (until end position is reached) | Actuator's spindle turns in counter-clockwise direction (until end position is reached) | - | - |
| No voltage at Y1 und Y2 | | Actuator's stem maintains the position | Actuator's spindle maintains the position | < 1 Ω | > 996 Ω |
| Voltage at Y1 for desired valve position % positioning time Example: SAX31.00 = 75% x 120 sec = 90 sec | | Actuator's stem extends to desired position (75%) | Actuator's spindle turns in clockwise direction to desired position (75%) | - | - |
| Check position value with ohmmeter | | Actuator's stem maintains the position | Actuator's spindle maintains the position | ~ 560 Ω | ~ 436 Ω |
| Voltage at Y2 for desired change of valve position % x positioning time Example: SAX31.00 = 10% x 120 sec = 12 sec | | Actuator's stem retracts to desired position (65%) | Actuator's spindle turns in counter-clockwise to desired position (65%) | - | - |
| Check position value with ohmmeter | | Actuator's stem maintains the position | Actuator's spindle maintains the position | ~ 485 Ω | ~ 511 Ω |

3.2.2 Commissioning Modbus RTU

The devices were developed specifically for use with Climatix pushbutton configuration as described in document CE1A3975 ¹⁾.

Alternatively, the bus can be configured via the local HMI; see section "User interface", pg. 53.

Check the following during commissioning:

- *Bus configuration* (address, baud rate, transmission format and optional termination). The initial address 255 ²⁾ allows multiple actuators to be mounted and commissioned at the same time without interfering with each other.
- *Actuator parameters* (opening direction, position limits, position adaption etc.). These values can be read via the Modbus register. Parameters may not be written cyclically.

¹⁾ Documents can be downloaded at <http://www.siemens.com/bt/download>

²⁾ The address 255 means "unassigned", and must be adjusted for the adapter to be operable.

Full or partial configuration via bus

The actuators can be configured via bus connection if the settings prior to commissioning allow for a connection to the Modbus client/programming tool and peripheral devices (i.e. non-conflicting addresses and matching baud rate/transmission format).

- *Full configuration via bus*: Given a unique Modbus address, the client/programming tool can establish a connection after start-up using the presets for transmission format and baud rate (or auto-baud).
- *Partial configuration via bus*: Given a non-unique Modbus address, the address must first be set to a unique value, either by inputting it with the pushbutton (cf. page 54) or by setting the address to 246 by pressing the pushbutton 5...10 seconds (cf. page 53). Subsequently, the client/programming tool can establish a connection after start-up using the presets for transmission format and baud rate (or auto-baud).

Once a connection is established, the bus and actuator parameters can be set via bus to the intended values. When writing to the bus parameters, "1 = Load" must be written to register 768 within 30 seconds; otherwise, the changes are discarded.

Example: The table shows the register values before and after the change via bus access.

| Reg. | Name | Before change | After change |
|------|---------------------|---------------|--------------|
| 764 | Modbus address | 246 | 12 |
| 765 | Baud rate | 0 = auto | 1 = 9600 |
| 766 | Transmission format | 0 = 1-8-E-1 | 3 = 1-8-N-2 |
| 767 | Bus termination | 0 = Off | 0 = Off |
| 768 | Bus conf. command | 0 = Ready | 1 = Load |

User interface

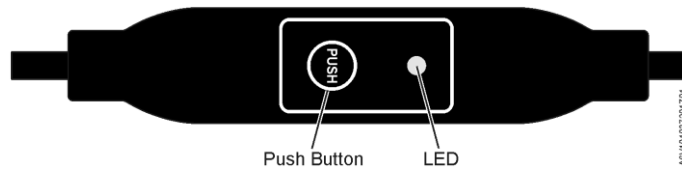

Pushbutton operation

| Action | Pushbutton operation | Feedback |
|---|---|---|
| Return current Modbus address (starting from lowest digit) | Briefly press button 1 x (<1 s) | <ul style="list-style-type: none"> 1st digit (single digit): red 10-digit (double digit): green 100-digit (triple digit): orange LED blinks blue 1 x after address indication if bus termination is switched on. Example: 124 = 4 x red, 2 x green, 1 x orange |
| Switch bus termination on/off | Switch on | LED stops blinking/flushing. |
| | 1. Press button 3 x Wait >1 s | |
| | <i>Within 10 s:</i> 2. Briefly press button 1 x (<1 s) | LED flashes blue 1 x blue (termination mode on). Button not pressed within 10 s: <ul style="list-style-type: none"> Address (and bus termination, if applicable) is indicated. Device enters normal mode. |
| | <i>Within 10 s:</i> 3. Press and hold button until LED turns red | LED is lit red (confirmation). Button not pressed within 10 s: <ul style="list-style-type: none"> Address (and bus termination, if applicable) is indicated. Device enters normal mode. |
| | 4. Release button | LED turns off. Address is indicated. LED blinks blue 1 x after address indication (termination mode on). Device enters normal mode. |
| | Switch off | LED stops blinking/flushing. |
| | 1. Press button 3 x Wait >1 s | |
| | <i>Within 10 s:</i> 2. Press and hold button until LED turns red | LED is lit red (confirmation). Button not pressed within 10 s: <ul style="list-style-type: none"> Address (and bus termination, if applicable) is indicated. Device enters normal mode. |
| 3. Release button | LED turns off. Address is indicated. [LED DOES NOT flash blue following address indication (termination mode off).] Device enters normal mode. | |
| Enter Modbus address with pushbutton | Press and hold button 1...5 s | See "Enter address using pushbutton", pg. 54 |
| Enable pushbutton addressing (use with Climatix™ controllers) | 1. Press and hold button 5...10 s | LED is lit red and turns off after 5 s. |
| | 2. Release button | LED is lit orange. |
| Reset to factory settings | Press and hold button >10 s | LED flashes orange. |

LED colors and blinking patterns

| Color | Blinking pattern | Description |
|------------------------------|---|---|
| Green | 1 s on / 5 s off | Normal mode without bus traffic |
| | Flickering | Normal mode with bus traffic |
| Orange ¹⁾ / green | 1 s orange / 1 s green | Override control mode |
| Orange ¹⁾ | 1 s on / 1 s off | Bus parameters not yet configured |
| | 1 s on / 5 s off | Backup mode (replacement mode) |
| Red | Permanently lit | <ul style="list-style-type: none"> • Mechanical error • Device jammed • Manual intervention • Calibration |
| | 1 s on / 5 s off | Internal error |
| | 0.1 s on / 1 s off | Invalid configuration, e.g. Min = Max |
| Blue | Flickering 1 x after address indication | Bus termination active |

¹⁾ The color of the orange LED can vary depending on the viewing angle, and appear more yellow or greenish.

Reset actuator with pushbutton

1. Press button >10s → LED blinking **orange**
2. Release button *while* blinking → LED blinking for another 3s
3. Reset is interrupted if the pushbutton is pressed *during* the 3s
4. After 3s, → LED is lit **red** (reset) while the device restarts.

Enter address using pushbutton

The Modbus address can be set without extra tool by means of pushbutton addressing.

To display the current Modbus address, press the button <1s.

Enter new address (starting from the lowest address position)

| Colors | | |
|--------------------------|--|--------------------------|
| 1st digit: red | 2nd digit: green | 3rd digit: orange |
| Example for address 124: | | |
| LED | | |
| Note | The address is entered and displayed beginning at the lowest digit (1st digit), see figure above. (Example: 124 starts with 4x red) | |

Enter new address (starting from lowest address position)

1. **Enable addressing mode:** Press button > 1s until the LED is **red**, then release button (before LED goes off).
2. **Enter the numbers:** Push button n-times → LED blinks each time the button is pressed as a feedback.
Colors: 1st digit: **red** / 2nd digit: **green** / 3rd digit: **orange**
3. **Save digits:** Press button until LED is lit in the color of the next digit, then release the button,
4. **Save address:** Press button until LED is **red** (confirmation) → then release button.
An address can be saved any time, i.e., after entering the 1st digit or after entering the 1st digit and 2nd digit.
5. The entered address is displayed again 1x for confirmation.

Note: Address entry is interrupted when the button is released before the LED is red, address entry is interrupted.

Example

Set address "124":

1. Enable addressing mode
2. Enter the 1st digit: Press button 4x → LED blinks **red** each time the button is pressed
3. Save 1st digit: Press button until LED is **green** – release button
4. Enter the 2nd digit: Press button 2x → LED blinks **green** each time the button is pressed
5. Save 2nd digit: Press button until LED is **orange** – release button
6. Enter the 3rd digit: Press button 1x → LED blinks **orange** each time the button is pressed
7. Save address: Press button until LED is **red** – release button
→ The address is saved and displayed 1x for confirmation

Set address "50":

1. Enable addressing mode
2. Skip over 1st digit: Press button until LED is **green** – release button
3. Enter the 2nd digit: Press button 5x → LED blinks **green** each time the button is pressed
4. Save address (skip 3rd digit): Press button until LED is **red** – release button
→ The address is saved and displayed 1x for confirmation

Set address "5":

1. Enable addressing mode
2. Enter the 1st digit: Press button 5x → LED blinks **red** each time the button is pressed
Save address: Press button until LED is **red** – release button
→ The address is saved and displayed 1x for confirmation

3.2.3 Maintenance

The actuators are maintenance-free.

3.2.4 Disposal



The device is considered electrical and electronic equipment for disposal in terms of the applicable European Directive and may not be disposed of as domestic garbage.

- Dispose of the device through channels provided for this purpose.
- Comply with all local and currently applicable laws and regulations.

4 Functions and control

4.1 3-position control

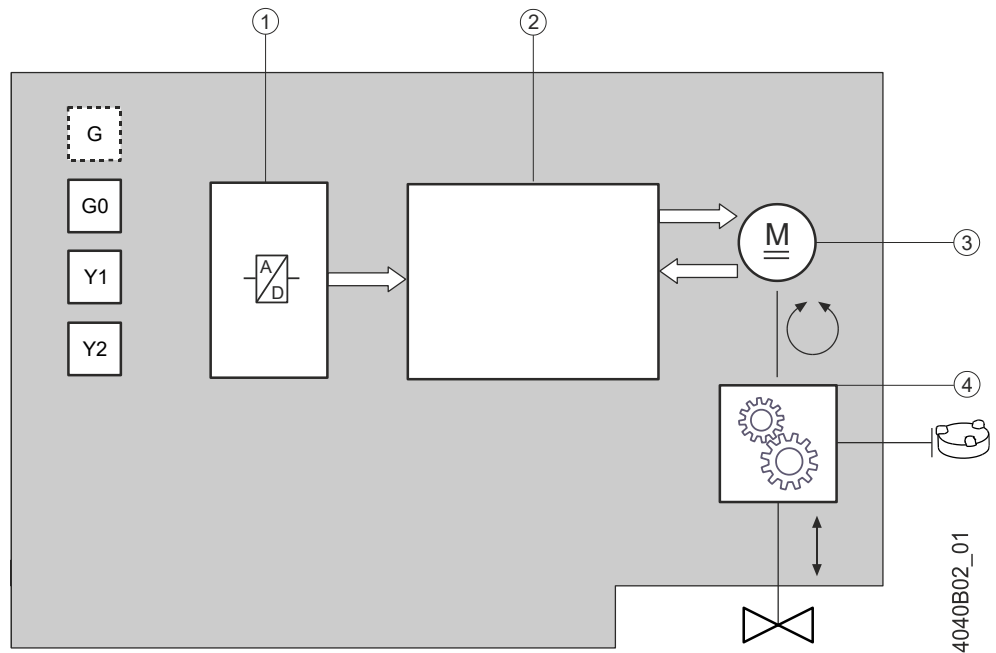

A 3-position signal drives the actuator via connection terminals Y1 or Y2. The required position is transferred to the valve.

| | | |
|---|--------------------|------------------------|
| 1 | A/D conversion | |
| 2 | Control functions | Identification of seat |
| | | Control of direction |
| | | Motor control |
| | | Manual adjustment |
| 3 | Brushless DC motor | |
| 4 | Gear train | |
| | Manual adjuster | |

| Positioning signal | Stroke actuator | Rotary actuator | Control path valve A → AB | Bypass valve B → AB |
|-------------------------|--|---|---------------------------|---------------------|
| Voltage at Y1 | Actuator's stem extends ¹⁾ | Actuator's spindle turns in clockwise direction | Opening | Closing |
| Voltage at Y2 | Actuator's stem retracts ¹⁾ | Actuator's spindle turns in counter-clockwise direction | Closing | Opening |
| No voltage at Y1 and Y2 | Actuator's stem maintains the position | Actuator's spindle maintains the position | Maintains the position | |
| Voltage at Y1 and Y2 | Actuator's stem maintains the position | Actuator's spindle maintains the position | Maintains the position | |

¹⁾ The opposite is true for SA...1P..

Note

Observe information given in chapter "Acting direction and flow characteristic" on page 63.

Internal control ensures very constant positioning times and determination of the actuator's position.

Positioning times stroke model

The specified positioning times refer to the respective nominal stroke / nominal angular rotation. Since the end positions of rotary actuators are inside the actuator, the following remarks refer to stroke actuators.
The resulting effective strokes vary, depending on the type of valve, resulting in shorter or longer actuator positioning times.

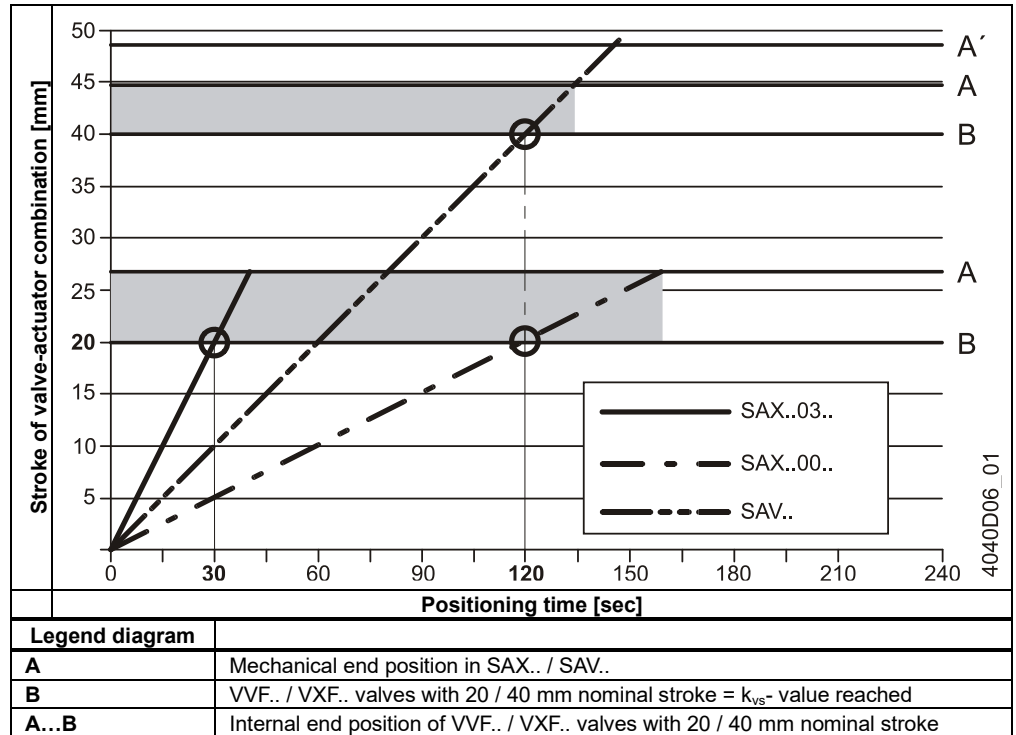

Notes

Deviations occur...

- after several positioning signals Y1 and Y2 in the same direction since the stroke movement starts with a delay of 300 ms.
- when positioning signals Y1 and Y2 are active for less than 300 ms since the stroke movement cannot be made in that case.

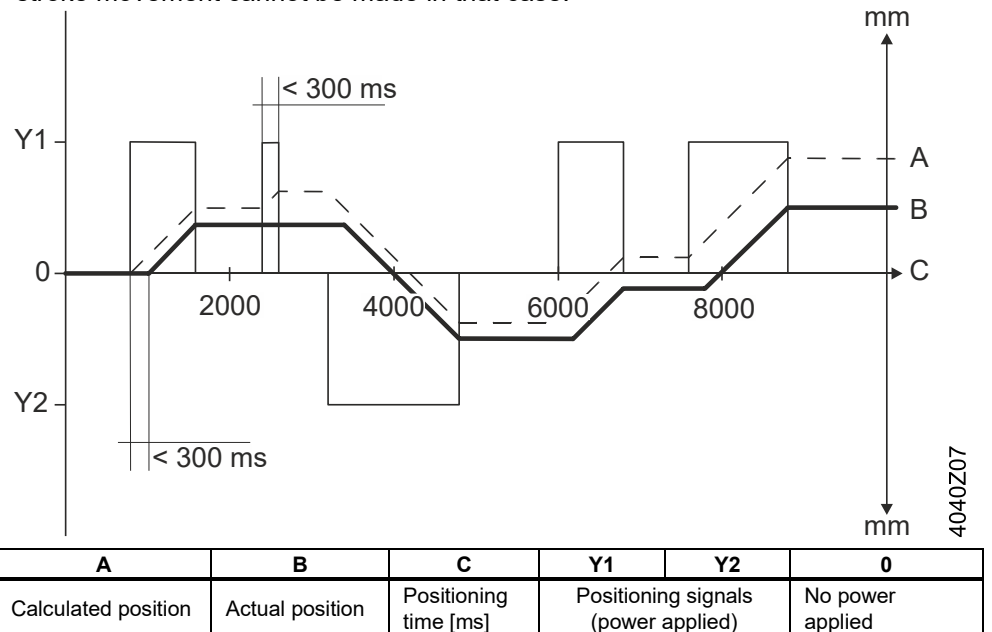

Notes

Accurate position feedback is made possible with the help of a potentiometer (page 78).

4.1.1 Combination with RVD.. controller for direct domestic hot water distribution by heat exchanger

The design based slow reaction on control signals of SAX31.., SAX81.., SAV31.., SAV81.., SAY31.., SAY81.., SAL31.. und SAL81.. actuators doesn't allow the actuator to react on very short control pulses. Only control pulses with a length greater than 300 ms allow a sufficient reaction.

Especially the direct domestic hot water control does not allow such long control pulses. The specific optimized control loops – equipped with an SIGMAGYR RVD.. controller and Acvatix SQS359.05 actuator– work with pulses down to 40 ms.

the actuators mentioned above are not able to work with these short pulses. The following table gives alternatives which actuators can be used within these control loops.

| Controller | Plant type | Prefered actuator | Valve line | DN | kvs |
|--|------------|--|--------------------|-----------|--------------------------|
| RVD130 ¹⁾ RVD135/109 ¹⁾ RVD135/309 ¹⁾ RVD140 RVD144/109 RVD145/109 RVD139 ¹⁾ | 4 and 5 | SQS35.53 ¹⁾ SAS31.53 ¹⁾ | VVG44.. | DN15 ..40 | 0.25 .. 25 |
| | | SQS359.05 ¹⁾ SAT31.008 | VVG549.. | DN15 ..25 | 0.25 .. 6.3 |
| | | SQS359.54 ¹⁾ SAT31.51 | VVG549.. | DN15 ..25 | 0.25 .. 6.3 |
| | | SKD32.21 | VVG41.. VVF53.. | DN15 ..50 | 0.63 .. 40 0.16 .. 40 |
| | | SKD32.21E | | DN15 ..50 | 0.63 .. 40 0.16 .. 40 |
| RVD230 ¹⁾ RVD235/109 ¹⁾ RVD250 RVD255/109 RVD240 ¹⁾ RVD245/109 ¹⁾ RVD260 RVD265/109 | .. - 4 | SQS35.53 ¹⁾ SAS31.53 | VVG44.. | DN15 ..40 | 0.25 .. 25 |
| | | SQS359.05 ¹⁾ SAT31.008 | VVG549.. | DN15 ..25 | 0.25 .. 6.3 |
| | | SQS359.54 ¹⁾ SAT31.51 | VVG549.. | DN15 ..25 | 0.25 .. 6.3 |
| | | SKD32.21 | VVG41.. VVF53.. | DN15 ..50 | 0.63 .. 40 0.16 .. 40 |
| | | SKD32.21E | VVG41.. VVF53.. | DN15 ..50 | 0.63 .. 40 0.16 .. 40 |

¹⁾ not available

4.2 Modulating control

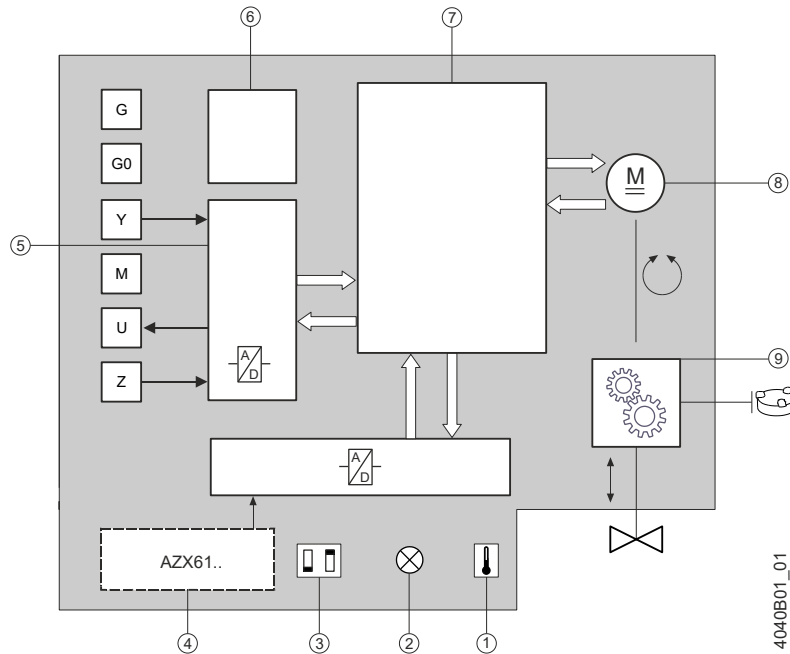

The positioning signal range (DC 0...10 V / DC 4...20 mA, 0...1000 Ω) corresponds in a linear manner to the positioning range (fully closed...fully open, or 0...100 % stroke).

The actuator is driven via connection terminal Y or forced control Z (page 68). The required stroke / rotation is transferred to the valve's stem / spindle.

| | | |
|-------------------|--------------------|------------------------------|
| 1 | Calibration slot | |
| 2 | LED (2 colors) | |
| 3 | DIL switches | Changeover of characteristic |
| | | Positioning signal |
| 4 | Function module | |
| 5 | A/D conversion | |
| 6 | Power supply | |
| 7 | Control functions | Identification of seat |
| | | Position control |
| | | Motor control |
| | | Detection of foreign bodies |
| | | Calibration |
| | | Forced control |
| | | Characteristics function |
| Manual adjustment | | |
| 8 | Brushless DC motor | |
| 9 | Gear train | |
| | | Manual adjuster |

| Positioning signal | Stroke actuator | Rotary actuator | Control path valve A→AB | Bypass valve B→AB |
|------------------------|--|--|-------------------------|-------------------|
| Signal Y, Z increasing | Actuator's stem extends ¹⁾ | Actuator's spindle turns in clockwise direction | Opening | Closing |
| Signal Y, Z decreasing | Actuator's stem retracts ¹⁾ | Actuator's spindle turns in counterclockwise direction | Closing | Opening |
| Signal Y, Z constant | Actuator's stem maintains the position | Actuator's spindle maintains the position | Maintains the position | |

¹⁾ The opposite is true for SA...1P..



Notes

- If function module AZX61.1 is used, observe the information given in chapter "Changeover of acting direction" (page 61).
- Observe the information given in chapter "Acting direction and flow characteristic" on page 63.

4.3 Function module AZX61.1

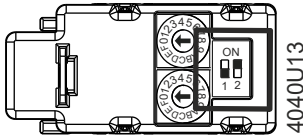
DIL switches

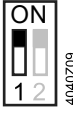
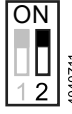

| | Acting direction | Sequence control |
|-------------------|---|---|
| OFF ¹⁾ |  4040Z10 Direct acting positioning signal Y or Z |  4040Z12 Sequence control not active |
| ON ¹⁾ |  4040Z09 Reverse acting positioning signal Y or Z |  4040Z11 Sequence control (signal adaptation) |

¹⁾ Factory setting: All switches set to OFF

The function module may not be used in combination with SA..61../MO.

4.3.1 Sequence control (signal adaptation)

DIL switches

| | Sequence control |
|------------------|---|
| ON ¹⁾ |  4040Z11 Sequence control (signal adaptation) |

¹⁾ Factory setting: All switches set to OFF

HEX switches

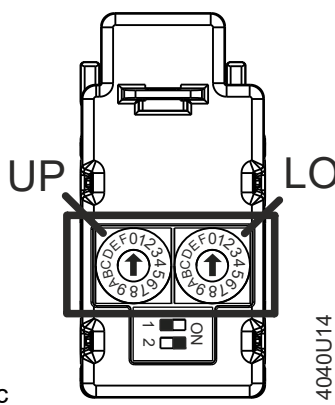
|  Nr.: 1 | Setting sequence control | | | | | | | | | | | | | | | | | |
|---|--|--|---------------|---------------|---|---|---|---|---|---|---|---|---|---|---|---|---|---|
| |  UP LO 4040U14 | Rotary switches LO and UP are used to set the starting point or working range of a sequence. | | | | | | | | | | | | | | | | |
| | Position "LO" | Starting point | Position "UP" | Working range | | | | | | | | | | | | | | |
| | 0 | 0,3 V | 0 | 9,4 V | | | | | | | | | | | | | | |
| | 1 | 1 V | 1 | 3 V | | | | | | | | | | | | | | |
| | 2 | 2 V | 2 | 4 V | | | | | | | | | | | | | | |
| | 3 | 3 V | 3 | 5 V | | | | | | | | | | | | | | |
| | 4 | 4 V | 4 | 6 V | | | | | | | | | | | | | | |
| | 5 | 5 V | 5 | 7 V | | | | | | | | | | | | | | |
| | 6 | 6 V | 6 | 8 V | | | | | | | | | | | | | | |
| | 7 | 7 V | 7 | 9 V | | | | | | | | | | | | | | |
| | 8 | 8 V | 8 | 10 V | | | | | | | | | | | | | | |
| | 9 | 9 V | 9 | 12 V | | | | | | | | | | | | | | |
| | A | 10 V | A | 14 V | | | | | | | | | | | | | | |
| | B | 11 V | B | 16 V | | | | | | | | | | | | | | |
| | C | 12 V | C | 18 V | | | | | | | | | | | | | | |
| | D | 13 V | D | 20 V | | | | | | | | | | | | | | |
| | E | 14 V | E | 25 V | | | | | | | | | | | | | | |
| | F | 15 V | F | 30 V | | | | | | | | | | | | | | |
| | Invalid HEX switches combinations | | | | | | | | | | | | | | | | | |
| | LO | 0 | 1 | 2 | 3 | 4 | 5 | 6 | 7 | 8 | 9 | A | B | C | D | E | F | |
| | UP | | F | F | F | F | F | F | F | F | F | F | D | D | C | C | C | B |
| | UP | | | | | | E | E | E | E | E | E | E | E | D | D | C | |
| | UP | | | | | | | | | | | | F | F | E | E | D | |
| | UP | | | | | | | | | | | | | | F | F | E | |
| | UP | | | | | | | | | | | | | | | | F | |

Notes

- Can only be used with voltage input.
- Maximum input voltage is DC 30 V. If the configuration is invalid, the actuator operates on DC 0...10 V.

Examples

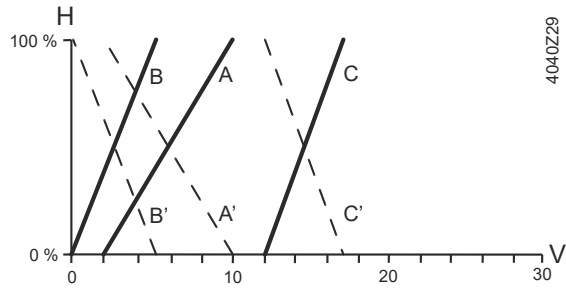

| Legend diagram | Positioning signal range | Position LO | Position UP | Position feedback U |
|----------------|--|-------------|-------------|---------------------|
| A | DC 2...10 V | 2 | 6 | DC 0...10 V |
| B | DC 0...5 V | 0 | 3 | DC 0...10 V |
| C | DC 12...17 V | C | 3 | DC 0...10 V |
| H | Stroke or rotary angle | | | |
| | Acting direction: Direct (A, B, C) | | | |
| | Acting direction: Reverse (A', B', C') | | | |

4.3.2 Changeover of acting direction

DIL switches

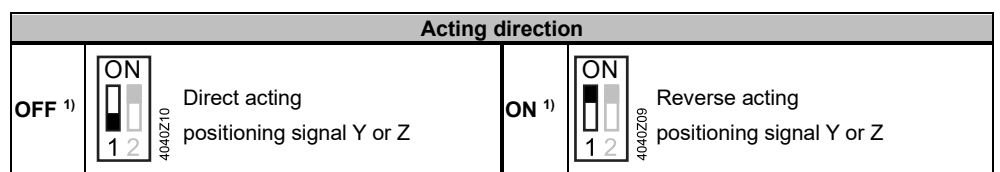

¹⁾ Factory setting: All switches set to OFF

Selecting the acting direction

- With valves whose stem is extended in the fully closed position, "direct acting" means that the actuator's stem is retracted when positioning signal Y = 0 V resp. Z = 0 Ω. This applies to all Siemens valves according to "Equipment combinations" (page 15).
- With valves whose stem is retracted in the fully closed position, "direct acting" means that the actuator's stem is extended when positioning signal Y = 0 V resp. Z = 0 Ω.

SAX61.03 SAV61.00

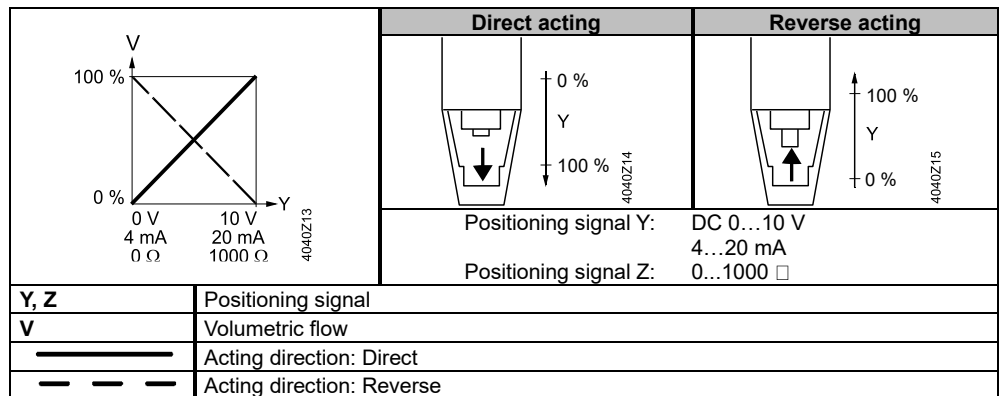

SAY61P03 SAX61P03 SAV61P00

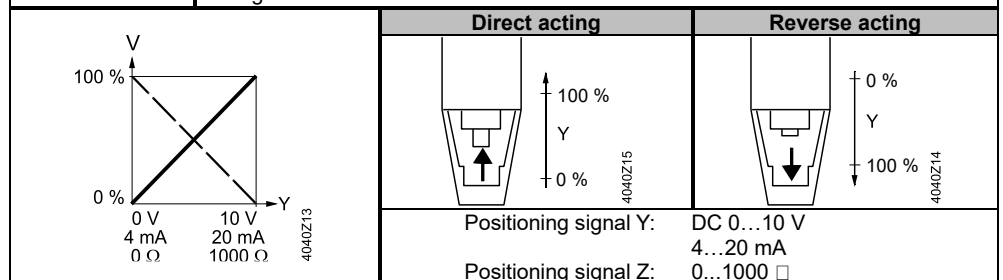



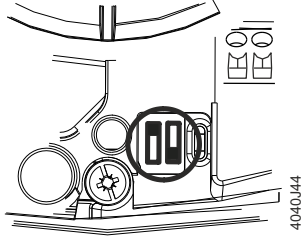

4.4 Positioning signal and flow characteristic selection

DIL switches

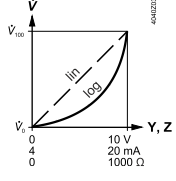

4040J44

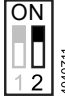
| | Positioning signal "Y" | Position feedback "U" | Flow characteristic | |
|-------------------|--|-----------------------|--|---|
| OFF ¹⁾ |  4040Z10 DC 0...10 V | DC 0...10 V |  4040Z12 log = equal-percentage |  |
| ON |  4040Z09 DC 4...20 mA | DC 0...10 V |  4040Z11 lin = linear | |

¹⁾ Factory setting: All DIL switches set to OFF Ω

Flow characteristic
SAX61.03 / SAV61.00
with VVF..

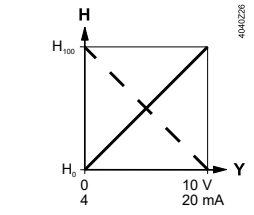
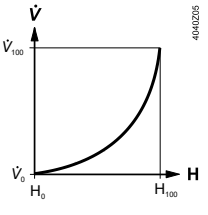
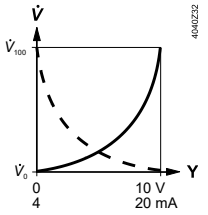
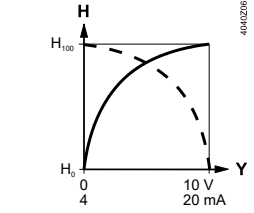
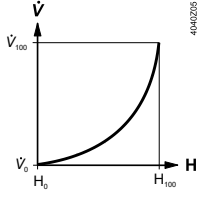
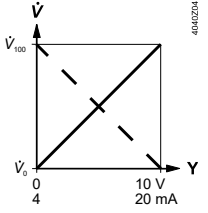
| | Actuator | Valve VVF.. / VVG41.. | Totally |
|-----|---|--|---|
| log |  4040Z26 |  4040Z05 |  4040Z22 |
| lin |  4040Z06 |  4040Z05 |  4040Z04 |

Flow characteristic
SAY61P03 / SAX61P03 /
SAV61P00 with VPF..

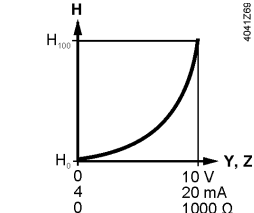
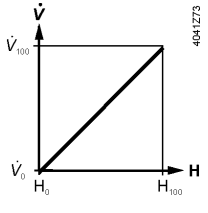
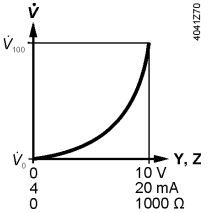
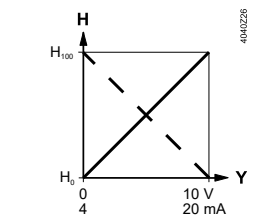
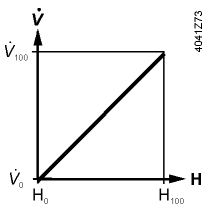
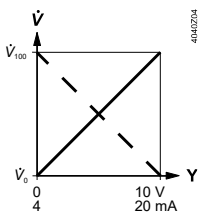
| | Actuator | Combi-Valve VPF43/VPF53 | Totally |
|---------|--|---|--|
| log |  4041Z69 |  4041Z73 |  4041Z70 |
| lin |  4040Z26 |  4041Z73 |  4040Z04 |
| Y, Z | Positioning signal | | |
| H | Stroke | | |
| V | Volumetric flow | | |
| — — — — | Acting direction: Direct | | |
| - - - - | Acting direction: Reverse | | |





Note

SAX61.03/MO: Positioning signal and flow characteristic selection are not permissible.

4.5 Acting direction and flow characteristic

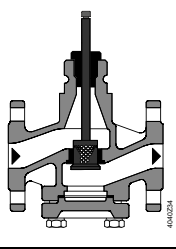
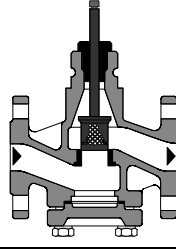

The selection of changeover of acting direction and characteristic with the DIL switches of the function module AZX61.1 depends on the type of actuator (with or without fail safe function) and the associated type of valve (valve characteristic, push to open, pull to open).

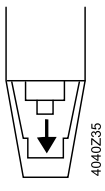
When the positioning signal increases (DC 0...10 V, DC 4...20 mA, 0...1000 Ω), the objective is to have the valve's volumetric flow V rising, but to fully open the valve, $V = 100\%$ (NO = normally open), or to fully close it, $V = 0\%$ (NC = normally closed) in the event of a power failure.

| | | | | | | |
|--|-----------------------------------|----------------------------|--|---|---|---|
| | | |  | |  | |
| | | |  |  |  |  |
|  | DIL switches | Acting direction | Direct | | Reverse | |
| | | Flow characteristic | Linear | Equal-percentage | Linear | Equal-percentage |
| | Without fail safe function | No power applied | Maintains the position | | | |

4.6 Position Feedback U

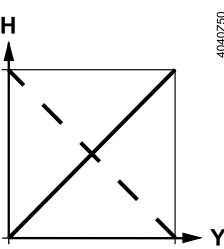
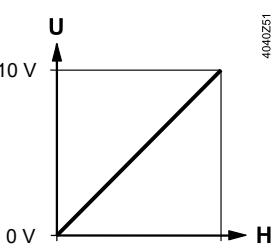
The position feedback U (DC 0...10 V) is always proportional to stroke H of the actuator's stem.

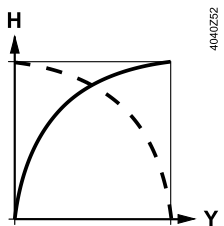
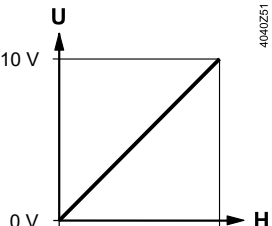
| | | Actuator Positioning signal Y, Z | Actuator Position feedback U |
|--|------------------------|---|--|
|  4040Z12 | log = equal-percentage |  4040Z50 |  4040Z51 |
|  4040Z11 | lin = linear |  4040Z52 |  4040Z51 |

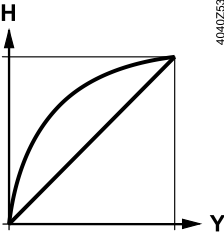
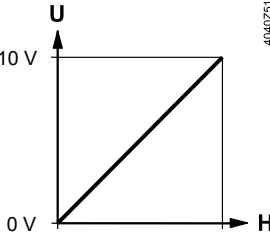
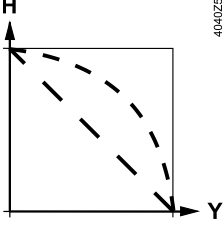
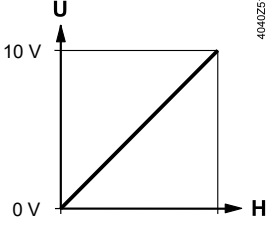
| | Actuator Positioning signal Y, Z | Actuator Position feedback U |
|----------------|--|---|
| Direct acting |  |  |
| Reverse acting |  |  |
| Y, Z | Positioning signal | |
| H | Stroke | |
| U | Position feedback | |
| ————— | Acting direction: direct | |
| - - - - - | Acting direction: reverse | |

4.7 Position control with ClosedPosition-Synchronization

Within SAX/SAV/SAL61/SAY61.. actuators the position control works based on the HALL-sensor pulses from the brushless DC-motor calculating with an internal stroke model calculating the actual position. This kind of control is more accurate and wearless compared with a physical element for position measurement and grants a precise position control with high resolution.

During manual operation the motor is declutched from the gear train and the internal position control get's not sensor pulses. So real position will deviate from the internally calculated position. As a consequence the position feedback on terminal U is set to "0V" during manual operation.

To grant – after manual operation – that real mechanical position and internal position control are matching all SA..61.. operate after manual operation an automatic ClosedPosition-Synchronization.

4.7.1 ClosedPosition-Synchronization

Returned into automatic operation the actuator runs for 0.5.. 2 s into opening direction to grant secure closed-position detection. Then the actuator runs into closed position (seat A-AB in the valve). Reaching the closed position the internal stroke model is synchronized. Positioning signal, position feedback and mechanical position now match perfectly again.

With this function it's granted that the position feedback U – which was zero during manual operation and synchronization - always represents the real mechanical position of the actuator.

After synchronization the actuator follows the control signal again.

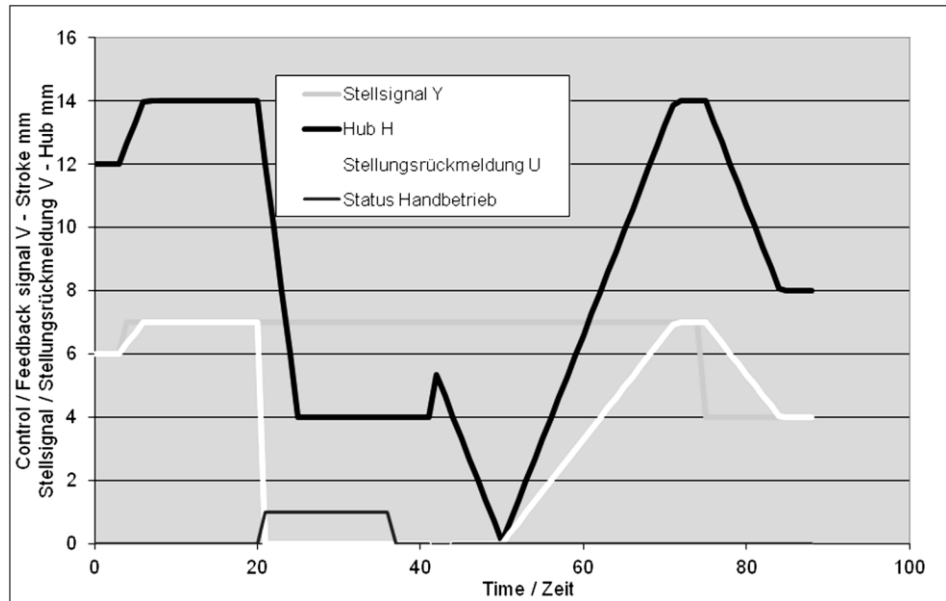

4.7.1.1 Active forced position input on Z

If after return to automatic mode a signal on Z is active (GND, AC/DC 24 V or 0...1000 Ohm) the ClosedPosition-Synchronization is deactivated as long as the signal on Z remains.

After Z is deactivated the ClosedPosition-Synchronization will be performed.

Note

ClosedPosition-Synchronization is only automatically activated after manual operation. A power failure does not activate this function automatically, to avoid that all actuators in a section close in parallel.

If the customer likes synchronization also after a power failure he should take care that the plant restarting routine drives the actuator automatically into an end position. This will also synchronize the internal position control and the real position.

4.8 Calibration

To match the actuator to production-related mechanical tolerances of the individual valves, accurate positioning and position feedback must be ensured, if calibration is performed when the plant is commissioned (page 49). During commissioning, the actuator detects the valve's end positions and files the exact stroke in its internal memory.

Calibration takes place in the following phases:

- Actuator drives to H_0 (1), valve closes. Detection of upper end position.
- Actuator drives to H_{100} (2), valve opens. Detection of lower end position.
- The detected values are stored (3). Then the actuator follows the positioning signal.

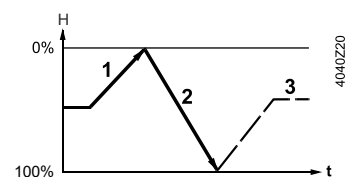

Note

- Observe status indication (actuator LED) during and after calibration (page 77).
- If the actuator does not detect the second end position within an appropriate stroke range (SAX61.0.. 8...22 mm; SAV61.0.. 16...44 mm), the first end stop will be adopted and the actuator operates with a working range of 20 mm, respectively 40 mm.

4.9 Signal priorities

The actuators are controlled via different interlinked positioning signal paths (positioning signal “Y”, forced control input “Z”, manual adjuster). The signal paths are assigned the following priorities:

| Priority | Description | |
|----------------|--|---|
| 1 (highest) | The manual adjuster always has priority 1, thus overriding all signals active at “Z” or “Y”, independent of whether or not power is applied. |  |
| 2 | Only SA..61...: As soon as a valid positioning signal is active at input “Z”, the position is determined via positioning signal “Z” (forced control). Prerequisite: The manual adjuster is not used. | Z |
| 3 (lowest) | The position is determined via positioning signal “Y”. The manual adjuster is not used and on Z there is no active signal. | Y |

Examples

| Manual adjuster | Forced control (Z) | Positioning signal (Y) | Stroke actuator | Rotary actuator |
|-----------------------------------|--------------------|------------------------|---|--|
| Automatic mode | Not connected | 5 V | Actuator’s stem travels to position (50%) | Actuator’s spindle travels to position (50%) |
| Automatic mode | G | 3 V | Actuator’s stem extends | Actuator’s spindle turns in clockwise direction |
| Automatic mode | G0 | 3 V | Actuator’s stem retracts | Actuator’s spindle turns in counter-clockwise direction |
| Operated (30%) and engaged | G | 8 V | Actuator’s stem retracts manual (to 30%) | Actuator’s spindle turns manual in counterclockwise direction (to 30%) |

Bold printing = positioning signal currently active

4.10 Detection of valve seat

The actuators feature force-dependent valve seat detection. After calibration, the exact valve stroke is filed in the actuator’s memory. When the actuator reaches the respective end of stroke, it does not hit the valve’s seat at full speed, but stops for 5 seconds at about 1% before the stored position is reached. If the positioning signal stays at 0% or 100%, the actuator travels to the calculated end position at reduced positioning speed and builds up the required nominal force.

This function extends the actuator’s service life since the dynamic forces are reduced when approaching the valve seat and there will be less strain on the gear train.

In addition, the actuator’s oscillations in the case of instable control are suppressed.

If no force is built up in the calculated end position (e.g. in the event of temperature effects for instance), the actuator continues to operate at a reduced positioning speed until the nominal positioning force is restored. This ensures that the valve always fully closes.

After a power failure, valve seat identification is not active – the actuators define their stroke position on power resoration to be at 50%. From now on, the actuator follows the positioning signal.

When the valve plug reaches its seat for the first time, the actuator readjusts its stroke model.

Example

The supposed position is 50%, $Y = 2\text{ V}$, the actuator travels 30% of the stored valve stroke in the direction of "Actuator's stem retracted".

If the actuator reaches the seat within this 30% travel, it interprets the position as "Valve fully closed" and shifts the position of the valve's stroke accordingly without changing the extent of travel.

From now on, the actuator follows the changed valve stroke position.

This means: New position 0%, $Y = 2\text{ V}$, actuator travels 20% of the stored valve stroke in the direction "Actuator's stem extended".

4.11 Detection of foreign bodies

The actuator detects when the valve is clogged and adjusts its operational behavior accordingly to prevent damage to itself or the valve.

If the actuator hits an obstacle within the calibrated stroke and is not able to overcome it with its nominal positioning force, it stores the position at which the obstacle was hit. Depending on the direction of travel, as ...

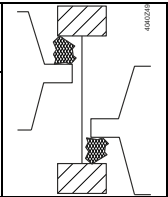
- | | |
|--|---|
| <ul style="list-style-type: none">• "Lower limit of valve clogging", if the clogging was detected when traveling in the direction of "Actuator's stem retracting". |  |
| <ul style="list-style-type: none">• "Upper limit of valve clogging", if the clogging was detected when traveling in the direction of "Actuator's stem extending". | |

Now, the actuator status LED blinks green and the actuator only follows the positioning signal between the positions "Actuator's stem retracted" and "Upper limit of valve clogging" or "Actuator's stem extended" and "Lower limit of valve clogging".

After detection of clogging, 3 attempts are made to overcome clogging by traveling about 15% in the opposite direction and then trying again to overcome the position of clogging. If the attempts made are unsuccessful, the actuator continues to follow the positioning signal within the restricted range only and the actuator LED continues to blink green (refer to "Indicators" on page 77).

4.12 Forced control Z

SA..61.. only

Forced control is affected by changeover of acting direction. It uses the following operating modes:

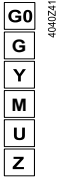
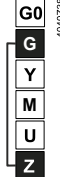
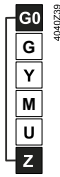
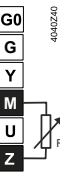
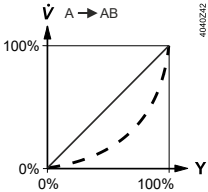
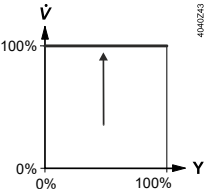
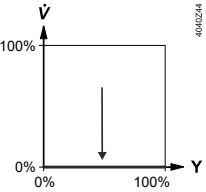
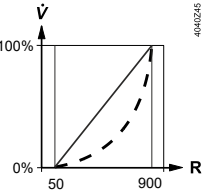
| | | Z-mode | | | |
|-------------|---|---|---|--|---|
| | | No function | Fully open | Fully closed | Overriding positioning signal "Y" by 0...1000 Ω |
| Connections |  |  |  |  | |
| | Transmission |  |  |  |  |
| | Equal-percentage or linear characteristic | | | | Equal-percentage or linear characteristic |
| | Contact "Z" not connected, valve follows positioning signal "Y" | Contact "Z" is connected directly to "G", positioning signal "Y" has no impact | Contact "Z" is connected directly to "G0", positioning signal "Y" has no impact | Contact "Z" is connected to "M" via resistor "R", starting point at 50 Ω, end point at 900 Ω, positioning signal "Y" has no impact | |

Note

The operating modes "Z" shown are based on factory setting "direct acting" and a "push to open" valve.

4.13 Communicating actuators Modbus RTU

4.13.1 Detection of valve seat

The actuators feature force-dependent valve seat detection. After calibration, the exact valve stroke is filed in the actuator's memory. When the actuator reaches the respective end of stroke, it does not hit the valve's seat at full speed, but stops for 5 seconds at about 1% before the stored position is reached. If the positioning signal stays at 0% or 100%, the actuator travels to the calculated end position at reduced positioning speed and builds up the required nominal force.

This function extends the actuator's service life since the dynamic forces are reduced when approaching the valve seat and there will be less strain on the gear train.

In addition, the actuator's oscillations in the case of instable control are suppressed. If no force is built up in the calculated end position (e.g. in the event of temperature effects for instance), the actuator continues to operate at a reduced positioning speed until the nominal positioning force is restored. This ensures that the valve always fully closes.

After a power failure, valve seat identification is not active – the actuators without fail safe function define their stroke position upon return of power at 50% and

automatically set their internal setpoint in register 1 to the startup setpoint (register 516). The actuator closes at this setting. There is a short-term deviation between the setpoint and the internal stroke position.

When the valve plug reaches each seat for the first time, the actuator readjusts its stroke mode.

Example

Setpoint prior to power outage 35%, no manual adjustment during the power outage. Internal stroke position value after return of power 50%. Internal setpoint after return of power equal to startup setpoint (register 516, here 0%). The actuator moves 35% in the direction of "Retract actuator stem" and reaches the valve seat (if the setpoint has not been changed in the meantime). The internal stroke position is set to 0%.

The actuator now follows the changed valve stroke position effective immediately.

4.13.2 Detection of foreign bodies

The actuator detects when the valve is clogged and adjusts its operational behavior accordingly to prevent damage to itself or the valve.

If the actuator hits an obstacle within the calibrated stroke and is not able to overcome it with its nominal positioning force, it stores the position at which the obstacle was hit. Depending on the direction of travel, as ...

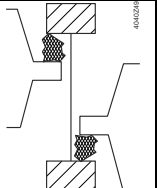
| | |
|--|--|
| <ul style="list-style-type: none"> • "Lower limit of valve clogging", if the clogging was detected when traveling in the direction of "Actuator's stem retracting". |  |
| <ul style="list-style-type: none"> • "Upper limit of valve clogging", if the clogging was detected when traveling in the direction of "Actuator's stem extending". | |

Now, the actuator status LED blinks green and the actuator only follows the positioning signal between the positions "Actuator's stem retracted" and "Upper limit of valve clogging" or "Actuator's stem extended" and "Lower limit of valve clogging".

After detection of clogging, 3 attempts are made to overcome clogging by traveling about 15% in the opposite direction and then trying again to overcome the position of clogging. If the attempts made are unsuccessful, the actuator continues to follow the positioning signal within the restricted range only and the actuator LED continues to blink green (refer to "Indicators" on page 77).

As long as the external setpoint is greater than the position of the high limit valve clogging, the deviation between the setpoint and position feedback in register 769 is displayed with the warning "Mechanical error, device jammed, manual intervention or calibration." The LED on the cable adapter is red. The warning is reset if the external setpoint drops below the high limit valve clogging, since the setpoint and stroke position are once again the same. The LED on the cable adapter switches to green blinking (=communication).

4.13.3 Calibration

To match the actuator to production-related mechanical tolerances of the individual valves, accurate positioning and position feedback must be ensured, if calibration is performed when the plant is commissioned (page 49). During commissioning, the actuator detects the valve's end positions and files the exact stroke in its internal memory.

Calibration takes place in the following phases:

- Actuator drives to H_0 (1), valve closes. Detection of upper end position.
- Actuator drives to H_{100} (2), valve opens. Detection of lower end position.
- The detected values are stored (3). Then the actuator follows the positioning signal.
- If the actuator does not detect the second end position within an appropriate stroke range (max. 25 mm), the first end stop will be adopted and the actuator operates with a working range of 20 mm.

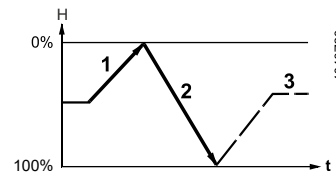

The internal position feedback is set to 0% during calibration. For a setpoint $> 0\%$, the actuator detects calibration based on the deviation between setpoint and stroke position and reports this in Register 769 with the warning “Mechanical error, device jammed, manual intervention or calibration”. The LED on the actuator cover blinks green, the LED on the cable adapter is red.

After calibration is completed, the actuator follows the external setpoint, the warning is reset, the LED on the cover changes to continuous green and the cable adapter blinks green (communication active).

Note

Observe status indication (LED) during and after calibration (page 77).
The calibration cannot be started via the bus.

4.13.4 Manual adjustment

The actuator's internal stroke position measurement is inactive during manual adjustment.

The position feedback changes to 0% once the manual adjuster is pressed and remains on the value during manual adjustment. The actuator detects manual action based on the deviation between the setpoint and the stroke position and after 10 seconds reports in register 769 with the warning “Mechanical error, device jammed, manual intervention or calibration”. The LED on the actuator cover blinks green, the LED on the cable adapter is red.

Upon return to automatic mode, the actuator synchronizes to stroke position 0%. After the synchronization, the actuator follows the pending setpoint, the LED on the cover changes to continuous green and, on the cable adapter, blinking green (communication active). The warning in register 769 is reset.

4.13.5 Modbus Registers

| Reg. | Addr. | Name | R/W | Unit | Scaling | Range / listing | Factory setting |
|---------------------------------|-------|---|-----|------|---------|---|---------------------|
| Process values | | | | | | | |
| 1 | 0 | Setpoint | RW | % | 0.01 | 0...100 % = 0...10000 | -- |
| 2 | 1 | Forced control | RW | -- | -- | 0 = Off / 1 = Open / 2 = Close 3 = Stop | |
| 3 | 2 | Actual value position | R | % | 0.01 | 0...100 % = 0...10000 | |
| 256 | 255 | Command | RW | -- | -- | 0 = Ready / 1 = Calibration in process / 2 = Self-test / 3 = Reinitialize / 4 = Remote reset | |
| Parameters ¹⁾ | | | | | | | |
| 262 | 261 | Actuator runtime | R | s | 1 | 30 | 30 s |
| 263 | 262 | Positioning signal characteristic between Y and U | RW | -- | -- | See A6V12050595 ("Reference documents" page 8) | [dependent on type] |
| 264 | 263 | Valve jam monitoring | RW | % | 0.01 | 0...100 % = 0...10000 | 4 % |
| 513 | 512 | Backup mode | RW | -- | -- | 0 = Move to backup position / 1 = Maintain last position / 2 = Deactivated | 2 = Deactivated |
| 514 | 513 | Backup position | RW | % | 0.01 | 0...100 % = 0...10000 | 0 % |
| 515 | 514 | Backup timeout | RW | s | 1 | 0...900 | 900 s |
| 516 | 515 | Startup setpoint | RW | % | 0.01 | 0...100 % = 0...10000 | 0 % |
| 764 | 763 | Modbus address | RW | -- | -- | 1...245 / 255 = "unassigned" ²⁾ 246 = On-event addressing 248 → 255 = "unassigned" | 255 |
| 765 | 764 | Baud rate | RW | -- | -- | 0 = Auto / 1 = 9600 / 2 = 19200 / 3 = 38400 / 4 = 57600 / 5 = 76800 / 6 = 115200 | 0 = Auto |
| 766 | 765 | Transmission format | RW | -- | -- | 0 = 1-8-E-1 / 1 = 1-8-O-1 / 2 = 1-8-N-1 / 3 = 1-8-N-2 | 0 = 1-8-E-1 |
| 767 | 766 | Bus termination | RW | -- | -- | 0 = Off / 1 = On | 0 = Off |
| 768 | 767 | Bus config. command | RW | -- | -- | 0 = Ready / 1 = Load / 2 = Discard | 0 = Ready |
| 769 | 768 | Status | R | -- | -- | See Section, Register 769 "State" | -- |

¹⁾ Parameters may not be written cyclically!

²⁾ If the address is set to 248 or higher, it is instead automatically set to the initial address 255 as soon as Reg. 268 is set to 1 ("Load").

| Reg. | Name | R/W | Value | Example |
|----------------------------|--------------------------------|-----|---|--|
| Statistics/Counters | | | | |
| 1025 | Cumulated up time (HWord) | R | HWord + LWord = cumulated time device has been on (hex), i.e. the motor has been running or holding, in seconds | <ul style="list-style-type: none"> • 1025 = 00 12 (hex) • 1026 = A2 E1 (hex) • 12A2E1 (hex) → 1221345 (dec) → Cum. up time = 1'221'345 s |
| 1026 | Cumulated up time (LWord) | R | | |
| 1027 | Cumulated running time (HWord) | R | HWord + LWord = cumulated running time (hex), i.e. for how long has the motor run, in seconds | <ul style="list-style-type: none"> • 1027 = 00 08 (hex) • 1028 = 12 51 (hex) • 81251 (hex) → 528977 (dec) → Cum. running time = 528.977 s |
| 1028 | Cumulated running time (LWord) | R | | |
| 1029 | Repositioning counter (HWord) | R | HWord + LWord = how often has the positioning signal been changed | <ul style="list-style-type: none"> • 1029 = 00 00 (hex) • 1030 = A0 01 (hex) • A001 (hex) → 40961 (dec) → Repositioned = 40.961 times |
| 1030 | Repositioning counter (LWord) | R | | |
| 1031 | Power-up counter | R | How often (hex) has the device been started up | <ul style="list-style-type: none"> • 1031 = 00 A2 (hex) → 162 (dec) → Powered up = 162 times |
| 1032 | Jam counter | R | How often (hex) has the device breached the valve jam tolerance (reg. 264) | <ul style="list-style-type: none"> • 1032 = 00 02 (hex) → 2 (dec) → Jams counted = 2 |

| Reg. | Name | R/W | Value | Example | | | | | | | | | | | | | | | | |
|---------------------------|---------------------------|-------|--|--|--|-------|-------|--|--|----|----|-------|-----|----|----|-------|-----|----|----|-------|
| Device information | | | | | | | | | | | | | | | | | | | | |
| 1281 | Factory index | R | Two bytes, each encoding an ASCII character | <ul style="list-style-type: none"> • 1281 = 00 5A (hex) → 0Z → Device is of series = "Z" | | | | | | | | | | | | | | | | |
| 1282 | Factory date (HWord) | R | Two bytes, the lower encoding the year (hex) | <ul style="list-style-type: none"> • 1282 = 00 18 (hex) • 1283 = 02 0F (hex) <table border="1" style="margin-left: 20px;"> <thead> <tr> <th></th> <th>HWord</th> <th colspan="2">LWord</th> </tr> <tr> <th></th> <th>--</th> <th>YY</th> <th>MM DD</th> </tr> </thead> <tbody> <tr> <td>Hex</td> <td>00</td> <td>18</td> <td>02 0F</td> </tr> <tr> <td>Dec</td> <td>00</td> <td>24</td> <td>02 15</td> </tr> </tbody> </table> → Device was manufactured = February 15, 2024 | | HWord | LWord | | | -- | YY | MM DD | Hex | 00 | 18 | 02 0F | Dec | 00 | 24 | 02 15 |
| | HWord | LWord | | | | | | | | | | | | | | | | | | |
| | -- | YY | MM DD | | | | | | | | | | | | | | | | | |
| Hex | 00 | 18 | 02 0F | | | | | | | | | | | | | | | | | |
| Dec | 00 | 24 | 02 15 | | | | | | | | | | | | | | | | | |
| 1283 | Factory Date (LWord) | R | Two bytes, HByte encoding the month (hex), LByte encoding the day (hex) | | | | | | | | | | | | | | | | | |
| 1284 | Serial number (HWord) | R | HWord + LWord = Serial no. (hex) | <ul style="list-style-type: none"> • 1284 = 00 0A (hex) • 1285 = A2 06 (hex) • → AA206 (hex) = 696838 (dec) → Device has serial no. = "696838" | | | | | | | | | | | | | | | | |
| 1285 | Serial number (LWord) | R | | | | | | | | | | | | | | | | | | |
| 1289 | Firmware version (HWord) | R | Two bytes, HByte corresponds to the major version, LByte corresponds to the minor version | <ul style="list-style-type: none"> • 1289 = 03 01 (hex) • 1290 = 03 07 (hex) → 775 (dec) → Firmware version = "03.01.0775" | | | | | | | | | | | | | | | | |
| 1290 | Firmware revision (LWord) | R | Two bytes, encoding the patch version (hex) | | | | | | | | | | | | | | | | | |
| 1291 | Hardware version | R | Two bytes, each encoding an ASCII character | <ul style="list-style-type: none"> • 1291 = 42 00 (hex) → Hardware version = "B" | | | | | | | | | | | | | | | | |
| 1409...16 | ASN [characters 16...1] | R | Two bytes per register, each of which encodes an ASCII character. First characters encoded in Reg. 1409. | <ul style="list-style-type: none"> • 1409 = 53 41 (hex) → SA • 1410 = 58 36 (hex) → X6 • 1411 = 31 2E (hex) → 1. • 1412 = 30 33 (hex) → 03 • 1413 = 2F 4D (hex) → /M • 1414 = 4F 00 (hex) → O → ASN = "SAX61.03/MO" | | | | | | | | | | | | | | | | |

Communication properties

| Communication | | |
|-------------------------|----------------------|--|
| Communications protocol | Modbus RTU | RS-485, not galvanically separated |
| | Number of nodes | Max. 32 |
| | Address range | 1...245 / 255 Factory settings: 255 |
| | Transmission formats | 1-8-E-1 / 1-8-O-1 / 1-8-N-1 / 1-8-N-2 Factory settings: 1-8-E-1 |
| | Baud rates (kBaud) | Auto / 9.6 / 19.2 / 38.4 / 57.6 / 76.8 / 115.2 Factory settings: Auto |
| | Bus termination | 120 Ω electronically switchable Factory settings: Off |

Supported function codes

| Function codes | |
|----------------|---|
| 03 (0x03) | Read Holding Registers |
| 04 (0x04) | Read Input Registers |
| 06 (0x06) | Write Single Register |
| 16 (0x10) | Write Multiple Registers (Limitation: Max. 120 registers on one write access) |

4.13.6 Function description

Register 1 / 3 “Setpoint / actual value”

The setpoint of the controller for the position to move to, 0...100% stroke/angle of rotation, resolution 0.01, i.e. 0% = 0 and 100% = 10000.

The actual value reported by the device, with the same resolution.

Register 2 “Override control”

The actuator can be operated in override control for commissioning / maintenance purposes or system-wide functions (e.g. night-cooling).

- Manual override: When the manual adjuster is used, a mechanical jam will be detected if a mismatch between setpoint and actual position persists for more than 10s.
- Remote override: The actuator enters this state when an override command is sent over the bus.
- Available commands:
 - Extend / Retract
 - Stop (with braking distance compensation)

Register 256 “Restarting the device”

Restarting is possible by:

- Power-reset (turning operating voltage off and on) or
- “Reinitialize” command.

→ Device re-initializes and sets all process values except actual value (= 50%) and setpoint (= startup setpoint) to defaults.

Register 256 “Self test”

When triggered, the self test drives the actuator to the detected limits and sets the flags in register 769 according to the result (bit 09 = 1 → “failed” or bit 10 = 1 → “passed”).

The self test is not passed when the limits were not reached from the lower end (results in jam). If the Min/Max limits can be exceeded, the self test is not evaluated as failed.

Notes

- The self test can only be performed if bit 4 = 0 in register 769 “Status”, meaning there is concurrently no clogging or manual operation.
- If clogging/a valve jam occurs during the self test, the test is failed, even if the device clears it within 3 tries.

| | |
|---|---|
| Register 256 “Reset” | <p>The actuator supports the following re-initialization / reset behaviour:</p> <ul style="list-style-type: none"> • Local reset by pushbutton • Remote reset: Using “Remote-Reset” command. <p>Effect of reset:</p> <ul style="list-style-type: none"> • Process values except actual value and setpoint: set to ex-works default values. • Network parameters (register 513...516 and 764...768) are reset only in case of local reset, not by remote reset (otherwise loss of communication). • Not reset are: Counters, device info, and factory data. |
| Register 259 “Operating mode” | Read value only, set to „Position control“ for valve actuators. |
| Register 260 / 261 “Minimum and maximum position” | Electronic positioning limitation |
| Register 262 “Actuator runtime” | Read value only, positioning time from one stop to another. |
| Register 263 “Positioning signal characteristic betw. Y and U” | Depending on the valve type, this function can be used to compensate a logarithmic characteristic, in order to achieve a linear input/output signal relation (cf. “Modbus Registers” table, page 71). |
| Register 264 “Tolerance valve jam monitoring” | If the setpoint does not reach the tolerance limit set within this parameter, bit 4 is set in register 769 “Status” and can be used for alarming in the building automation system. |
| Register 513...515 “Backup mode” | <p>In case the communication to the controller is lost, the device can be configured to go into a defined state.</p> <ul style="list-style-type: none"> • Waiting time to recognize communication loss → Register 515 • Reaction: <ul style="list-style-type: none"> – Go to a predefined backup position → Register 514 – Deactivated (factory setting): “keep last setpoint”, i.e. in case of communication loss, the device controls to the last received setpoint, until a new valid setpoint is received. |
| Register 516 “Startup setpoint” | In this parameter a setpoint can be defined, which the actuator moves to at first commissioning or after a power reset, before receiving a new valid setpoint. |
| Register 764...766 “Modbus configuration” | Configuring the RS-485 address and transmission parameters |
| Register 767 “Bus termination” | Electronically switchable 120 Ω resistance for bus termination |
| Register 768 “Bus config. Command” | If the parameters in registers 764...766 „Modbus configuration“ are changed via bus, they are only saved if the function “Load” is called within 60 seconds in this register. Otherwise, all changes are discarded. |

Register 769 “State”

In register, 769 the bits are set according to the table below, representing the current status information.

| Service flags | | | |
|---------------|---|--------|--------------------------|
| Bit 00 | 1 = Not available | Bit 06 | 1 = Not available |
| Bit 01 | 1 = Backup mode active | Bit 07 | 1 = Not available |
| Bit 02 | 1 = Not available | Bit 08 | 1 = Not available |
| Bit 03 | 1 = Not available | Bit 09 | 1 = Self test failed |
| Bit 04 | 1 = Mechanical error, device jammed, manual intervention ¹⁾ or calibration ¹⁾ | Bit 10 | 1 = Self test successful |
| Bit 05 | 1 = Not available | Bit 11 | 1 = Not available |

¹⁾After 10 seconds

4.14 Technical and mechanical design

4.14.1 Transmission of power

Function principle

Incoming positioning signals are translated to positioning commands for the motor.

A gear train transmits the motor's positioning steps to the output stage (valve coupling). Attached to the gear train are the electrical and mechanical accessory items and the manual adjuster.

In the case of the rotary actuators, the adjustment to the required torque is made in the output stage. With the stroke actuators, the translation from rotary to stroke movement takes place in the output stage.

SAL..

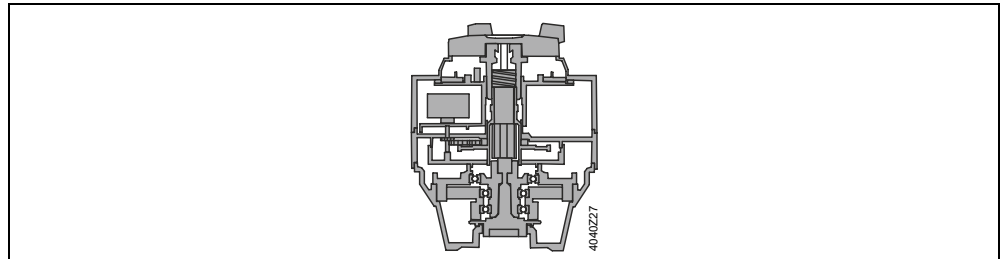

SAX.., SAV..

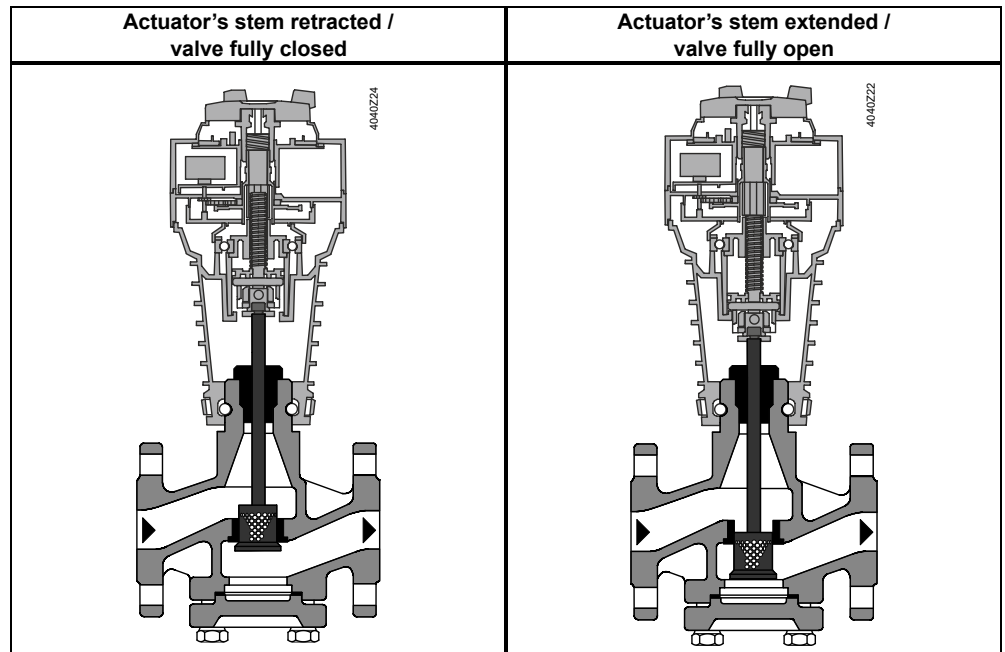

4.14.2 Coupling

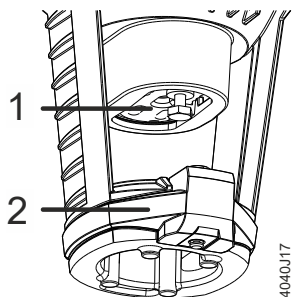
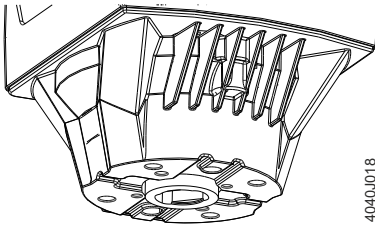
| SAX.., SAV.. | SAL.. |
|---|---|
|  |  |
| <p>The stem coupling (1) and neck coupling (2) ensures full backward compatibility with all types of Siemens large-stroke valves produced since 1975.</p> | <p>Mounting sets are available for use with butterfly and slipper valves.</p> |

4.14.3 Manual adjuster

Automatic

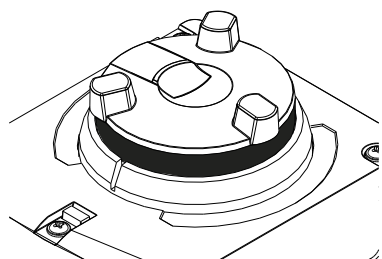
| | |
|--|--|
|  | <p>When the motor drives the manual adjuster turns. Thus in automatic mode, the manual adjuster is used for indication of travel. If the manual adjuster is held firm in this mode, there is no transmission of power to the gear train.</p> |
|--|--|

Manual operation

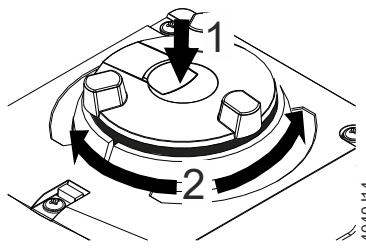
| | |
|---|--|
|  | <p>When pushing the manual adjuster down (1), it engages and the actuator can be manually operated.</p> <p>Stroke actuator: When turning the manual adjuster in clockwise / counterclockwise direction (2), the actuator's stem retracts / extends.</p> <p>Rotary actuator: The actuator spindle turns in the same direction.</p> <p>An overload protection prevents damage to the manual adjuster</p> |
|---|--|

Fixing the position

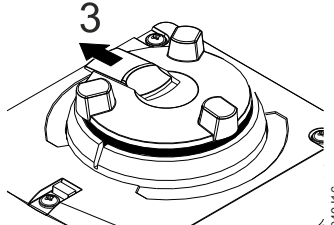
| | |
|---|---|
|  | <p>Upon actuation and locking the slide switch, the manual adjuster remains engaged.</p> <p>When in this mode, do not turn the manual adjuster.</p> |
|---|---|

Disengaging the fixing

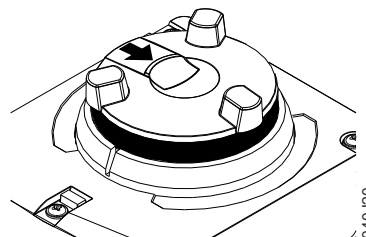
| | |
|---|---|
|  | <p>When resetting the slide switch, the manual adjuster returns to automatic mode.</p> <p>->The modulating SA..61.. will automatically start a Zero Position Synchronization</p> |
|---|---|

4.14.4 Indicators

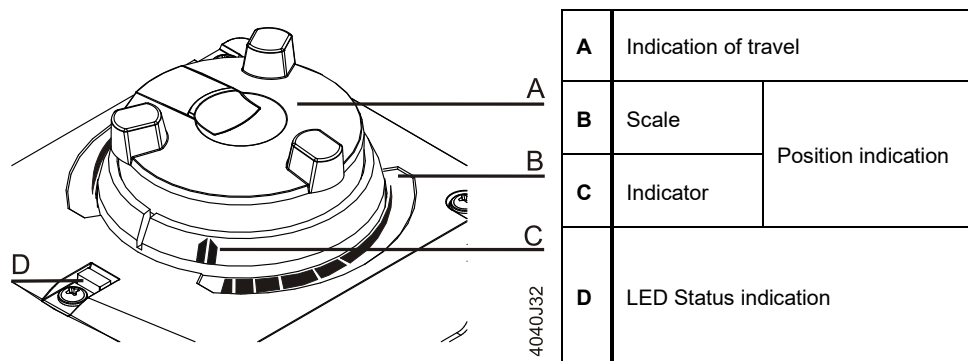

Operational status indication

In Automatic mode, the manual adjuster serves for the indication of travel. See "Automatic" (page 76).

Position indication

Position indication is on 2 opposite sides. When turning the manual adjuster, the indicator moves in the same direction.

The scale indicates the stroke. When reaching the stops, the valve is either fully open or fully closed.

Status indication (LED)

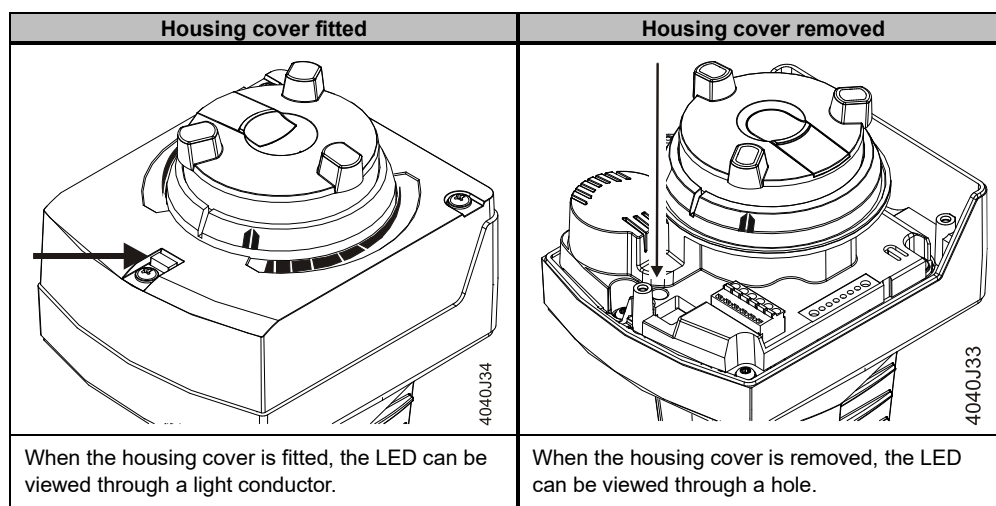

The status indication informs about the operational state of the actuator.

| LED | Indication | Operating state | Remarks, troubleshooting |
|--------------|------------|--|--|
| Green | On | Automatic mode | Normal operation |
| | Blinking | Calibration (page 49). | Wait until calibration is finished (then green or red light) |
| | | In manual mode Detection of foreign bodies (page 67 / page 69). | Manual adjuster in MAN position Check valve / actuator |
| Red | On | Undervoltage | Check voltage |
| | | Maximum stroke exceeded | Start calibration again (page 49). If error re-occurs immediately: actuator faulty. |
| | Blinking | Calibration error | Start calibration again. |
| | | Clogged valve | If error re-occurs immediately: check valve |
| Dark | Dark | No power or electronics faulty | Check operating voltage |

4.14.5 Electrical accessories

Auxiliary switch ASC10.51



The auxiliary switch ASC10.51 switches on or off when a certain position is reached. The switching point can be set between 0...100%.

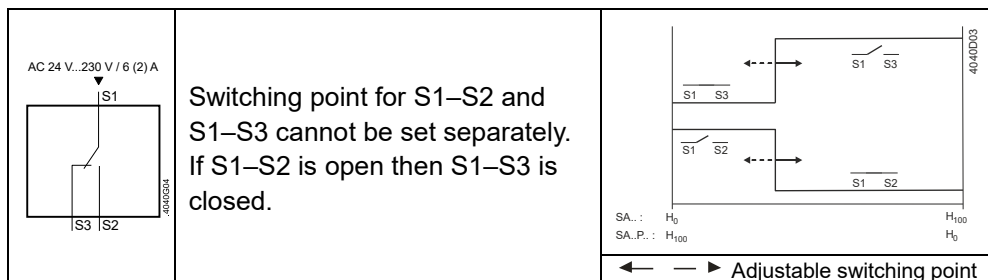

Application example:

When using an auxiliary switch, position feedback can trigger an automatic stop of the circulating pump in the end position "Fully closed".

Potentiometer ASZ7.5/..

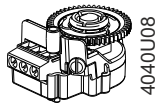

Potentiometer ASZ7.5 delivers an ohmic value to the controller giving the exact position of the actuator (continuous position feedback). A slip clutch prevents damage to the potentiometer in the mechanical end positions. This is also used for accurate balancing of the potentiometer in the fully closed position.

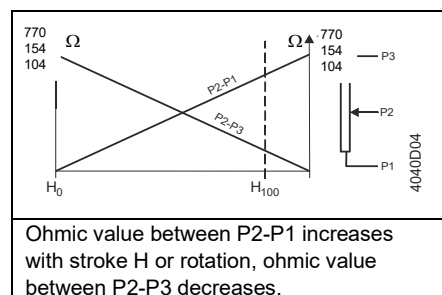

Flow characteristic

The end values of the potentiometers refer to the maximum stroke / maximum angular rotation of the actuators. For this reason, the resulting values in operation deviate, depending on the type of valve used in combination with the actuator. The potentiometer's starting point can be very accurately adjusted during installation (refer page 41).

| ASZ7.5 | |
|--------|--|
| | 770 Ohm at nominal stroke/nominal angular rotation |
| | $R = 0 + 7.7 \text{ Ohm} \times \text{nominal stroke/nominal angular rotation (\%)}$ |
| SAX.. | $R = 0 + 38.5 \text{ Ohm} \times \text{stroke (mm)}$ |
| SAV.. | $R = 0 + 19.3 \text{ Ohm} \times \text{stroke (mm)}$ |
| SAL.. | $R = 0 + 8.55 \text{ Ohm} \times \text{rotary angle (}^\circ\text{)}$ |

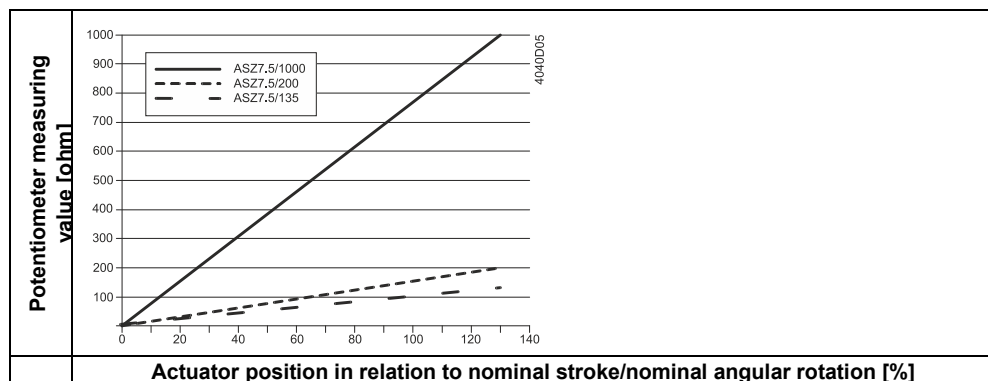

Function module AZX61.1

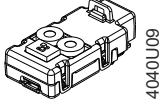

Function module AZX61.1 offers the following choices for changing control:

- Changeover of acting direction (page 61)
- Sequence control (page 60)

Stem heating element ASZ6.6

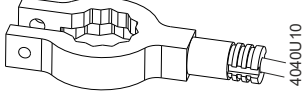

Stem heating element ASZ6.6 prevents the formation of ice on the stem when medium temperatures drop below 0 °C. It is suited for universal use with valves having a stem diameter of 10 or 14 mm.



The stem heating element heats up to 85 °C.



This is a PTC element, which means it shows up with a low resistance at power up – inrush current may reach 8.5 A at low temperatures / high voltage level

4.14.6 Mechanical accessories

Weather shield ASK39.1

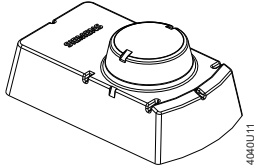

Weather shield ASK39.1 protects the actuator when installed outdoors. This does not lead to a change of IP class (IP54).

SA..61../MO are not suitable for outdoor applications

Mounting sets ASK3..N

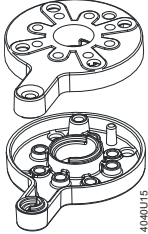

Mounting sets ASK31N, ASK32N, ASK33N and ASK35N enable the actuators to be fitted to slipper valves VBF21..., DN65...150 and butterfly valves VKF41.. and VKF45 (page 29-36).

5 Technical data

| Power consumption at 50Hz | | Running | | Holding | |
|--|------------------|---------|------|---------|------|
| Type | Stock no. | [W] | [VA] | [W] | [VA] |
| Stroke actuators | | | | | |
| SAX31.00 | S55150-A105 | 2.2 | 3.9 | 1.3 | 2.2 |
| SAX31.03 | S55150-A106 | 4.6 | 7.9 | | |
| SAX61.03 | S55150-A100 | 2.5 | 6.3 | 1.7 | 4.6 |
| SAX61.03U | S55150-A100-A100 | | | | |
| SAX61.03/MO | S55150-A140 | 3 | 7.0 | 2.2 | 6.0 |
| SAX81.00 | S55150-A102 | 2.3 | 4.0 | 1.5 | 2.7 |
| SAX81.03 | S55150-A103 | 4.3 | 7.2 | | 2.6 |
| SAX81.03U | S55150-A103-A100 | | | | |
| SAV31.00 | S55150-A112 | 4.1 | 7.2 | 1.3 | 2.3 |
| SAV61.00 | S55150-A110 | 4.0 | 9.5 | 1.7 | 4.4 |
| SAV61.00U | S55150-A110-A100 | | | | |
| SAV61.00/MO | S55150-A141 | 4.5 | 10.2 | 2.2 | 5.8 |
| SAV81.00 | S55150-A111 | 4.0 | 6.9 | 1.5 | 2.7 |
| SAV81.00U | S55150-A111-A100 | | | | |
| Stroke actuators – combi valves | | | | | |
| SAY31P03 | S55150-A132 | 2.2 | 4.0 | 1.3 | 2.2 |
| SAY61P03 | S55150-A133 | 2.7 | 6.5 | 1.7 | 4.5 |
| SAY61.03U | S55150-A135 | 2.6 | | | |
| SAY61P03/MO | S55150-A145 | 3.2 | 7.2 | 2.2 | 5.9 |
| SAY81P03 | S55150-A134 | 2.4 | 4.2 | 1.5 | 2.6 |
| SAY81.03U | S55150-A136 | 2.5 | 4.3 | | 2.5 |
| SAX31P03 | S55150-A118 | 3.9 | 7.0 | 1.3 | 2.2 |
| SAX61P03 | S55150-A114 | 3.8 | 9.0 | 1.7 | 4.5 |
| SAX61P03/MO | S55150-A143 | 4.3 | 9.7 | 2.2 | 5.9 |
| SAX81P03 | S55150-A116 | 3.5 | 6.2 | 1.5 | 2.7 |
| SAV31P00 | S55150-A121 | 4.0 | 7.1 | 1.3 | 2.3 |
| SAV61P00 | S55150-A119 | 3.5 | 8.4 | 1.7 | 4.5 |
| SAV61P00/MO | S55150-A144 | 4.0 | 9.1 | 2.2 | 5.9 |
| SAV81P00 | S55150-A120 | 3.4 | 5.9 | 1.5 | 2.7 |
| Rotary actuators | | | | | |
| SAL31.00T10 | S55162-A108 | 1.9 | 3.4 | 1.2 | 2.1 |
| SAL31.00T20 | S55162-A110 | 2.7 | 4.9 | 1.3 | 2.5 |
| SAL31.00T40 | S55162-A111 | 3.7 | 6.6 | 1.4 | 2.4 |
| SAL31.03T10 | S55162-A109 | | | 1.3 | 2.2 |
| SAL31.03T10/F05 | S55162-A121 | | | | |
| SAL61.00T10 | S55162-A100 | 2.2 | 5.7 | 1.7 | 4.5 |
| SAL61.00T20 | S55162-A102 | 3.1 | 7.6 | 2 | 5.1 |
| SAL61.00T40 | S55162-A103 | 3.9 | 9.2 | 4.8 | 4.8 |
| SAL61.03T10 | S55162-A101 | 4.0 | 9.5 | 1.8 | 4.6 |
| SAL61.03T10/F05 | S55162-A123 | | | | |
| SAL81.00T10 | S55162-A104 | 2.3 | 3.9 | 1.5 | 2.6 |
| SAL81.00T20 | S55162-A106 | 3.0 | 5.1 | | 2.7 |
| SAL81.00T40 | S55162-A107 | 4.1 | 7.0 | 1.7 | 2.9 |
| SAL81.03T10 | S55162-A105 | 3.6 | 6.1 | 1.5 | 2.6 |
| SAL81.03T10/F05 | S55162-A122 | | | | |

| | | SAY.. | SAX.. | SAV.. | SAL.. |
|---------------------------|---|---|---|----------------|---|
| Power supply | Operating voltage SA..31.. SA..61.. SA..81.. | AC 230 V ± 15 % AC 24 V ± 20 % / DC 24 V + 20 % / -15 % (SELV) AC 24 V ± 20 % / DC 24 V + 20 % / -15 % (SELV) | | | |
| | Frequenz | 45...65Hz | | | |
| | External supply line protection (EU) | <ul style="list-style-type: none"> 6 A...10 A slow Circuit breaker max. 13 A Characteristic B, C, D according to EN 60898 Power source with current limitation of max. 10 A | | | |
| | Switch-on current 3-position actuators (typical) ¹⁾ SA..31.. SA..81.. | 2.3 A 4.5 A | 2.3 A 4.5 A | 2.3 A 4.5 A | 2.3 A 4.5 A |
| Function data | Positioning times with specified nominal stroke / nominal angular rotation SAX..00, SAV.., SAL..00 SAY..03, SAX..03.., SAL..03 | 30 s | 120 s 30 s | 120 s - | 120 s 30 s |
| | Positioning force | 200 N | 800 N | 1600 N | - |
| | Torque SAL..T10 SAL..T20 ²⁾ SAL..T40 ²⁾ | | - - - | - - - | 10 Nm running 20 Nm running 40 Nm running |
| | Nominal stroke | 15 mm | 20 mm | 40 mm | - |
| | Angular rotation | | - | - | 90° |
| | Signal inputs | Positioning signal "Y" SA..31.., SA..81.. SA..31.. Voltage SA..81.. Voltage SA..61.. (DC 0...10 V) Current draw Input impedance SA..61.. (DC 4...20 mA) Current draw Input impedance | 3- position AC 230 V ± 15 % AC 24 V ± 20 % / DC 24 V + 20 % / -15% ≤ 0,1 mA ≥ 100 kΩ DC 4...20 mA ± 1 % ≤ 500 Ω | | |
| Communication | Communications protocol Modbus RTU Number of nodes Address range Transmission formats Baud rates (kBaud) Bus termination | RS-485, not galvanically separated Max. 32 1...245 / 255 Factory settings: 255 1-8-E-1 / 1-8-O-1 / 1-8-N-1 / 1-8-N-2 Factory settings: 1-8-E-1 Auto / 9.6 / 19.2 / 38.4 / 57.6 / 76.8 / 115.2 Factory settings: Auto 120 Ω electronically switchable Factory settings: Off | | | |
| Parallel operation | SA..61.. | ≤ 10 (depending on controller output) | | | |
| Forced control | Positioning signal "Z" SA..61.. R = 0...1000 Ω | R= 0...1000 Ω, G, G0 Stroke / rotation proportional to R | | | |
| | Z connected to G Z connected to G0 | Max. stroke 100% ³⁾ Min. stroke 0% ³⁾ | | | 90° ³⁾ 0° ³⁾ |
| | Voltage | Max. AC 24 V ± 20 % Max. DC 24 V + 20 % / -15% | | | |
| | Current draw | ≤ 0,1 mA | | | |
| Position feedback | Position feedback U SA..61.. Load impedance Load | DC 0...10 V >10 kΩ res. Max. 1 mA | | | |
| Connecting cable | Wire cross-sectional areas | 0.13...1.5 mm ² , AWG 24...16 ⁴⁾ | | | |
| | Cable entries SA.. SA..U SA..61../MO | EU: 2 entries Ø 20.5 mm (for M20) 1 entry Ø 25.5 mm (for M25) US: 3 entries Ø 21.5 mm for ½" tube connection Fixed connecting cable: 0.9 m Number of wires: 5 x 0.75 mm ² | | | |

| | | SAY.. | SAX.. | SAV.. | SAL.. |
|--|---|---|---|----------------------------|----------------------------|
| Degree of protection | Housing from vertical to horizontal | IP54 as per EN 60529 ⁵⁾ | | | |
| | Insulation class | As per EN 60730 | | | |
| | Actuators SA..31.. | AC 230 V | II | | |
| | Actuators SA..61.. | AC / DC 24 V | III | | |
| | Actuators SA..81.. | AC / DC 24 V | III | | |
| Environmental conditions | Operation | IEC 60721-3-3 | | | |
| | Climatic conditions | Class 3K5 | | | |
| | Mounting location | Indoors (weather-protected) ⁶⁾ | | | |
| | Temperature General | -15...55 °C | | | |
| | Humidity (noncondensing) | 5...95 % r.h. | | | |
| | Transport | IEC 60721-3-2 | | | |
| | Climatic conditions | Class 2K3 | | | |
| | Temperature | -25...70 °C | | | |
| | Humidity | <95 % r.h. | | | |
| | Storage | IEC 60721-3-1 | | | |
| | Climatic conditions | Class 1K3 | | | |
| | Temperature | -15...55 °C | | | |
| | Humidity | 5...95 % r.h. | | | |
| | Max. media temperatur when mounted on valve | 130 °C | 130 °C | 130 °C ⁷⁾ | 120 °C |
| Directives and Standards | Product standard | EN60730-x | | | |
| | Electromagnetic compatibility (Application) | For residential, commercial and industrial environments | | | |
| | EU Conformity (CE) | A5W00000333 ⁸⁾ | CE1T4501x1 ⁸⁾ | CE1T4503xx ⁸⁾ | CE1T4502X1 ⁸⁾ |
| | UK Conformity (UKCA) | A5W00198022A ⁸⁾ | A5W00185581A ⁸⁾ | A5W00197822A ⁸⁾ | A5W00196130A ⁸⁾ |
| | RCM Conformity AC 230 V | A5W00000334 ⁸⁾ | CE1T4515X4 ⁸⁾ | CM1T4503_C1 ⁸⁾ | - |
| | EAC Conformity | Eurasia conformity for all SA.. variants | | | |
| | UL, cUL AC 230 V | - | | | |
| | AC/DC 24 V | UL 873 http://ul.com/database ; File number E35198 | | | |
| Environmental compatibility | | The product environmental declarations contain data on environmentally compatible product designs and assessments (RoHS compliance, materials composition, packaging, environmental benefit, disposal): | | | |
| | | 7173310559Ben ⁷⁾ | 7173310559Ben ⁷⁾ A6V101083254 ⁷⁾ | 7173310522A ⁷⁾ | CE1E4502en ⁷⁾ |
| Dimensions | | See "Dimensions" (page 87) | | | |
| Weight | Excl. packaging | See "Dimensions" (page 87) | | | |
| Accessories | Potentiometer ASZ7.5 ⁹⁾ | 0...1000 Ω ± 5% | | | |
| | Voltage | DC 10 V (SELV) | | | |
| | Current rating | < 4 mA | | | |
| | Auxiliary switch ASC10.51 ⁹⁾ | AC 24...230 V, 6 (2) A, floating | | | |
| | Switching capacity | | | | |
| External supply line protection | See section power supply | | | | |
| US installation, UL & cUL | AC 24 V class 2, 5 A general purpose | | | | |
| Stem heating element ASZ6.6 | Stem heating element ASZ6.6 cannot be combined with SAL.. | | | | |
| Power supply | AC / DC 24 V ± 20 % | | | | |
| Power consumption at 50 Hz | 50 VA / 30 W | | | | |
| Inrush current (cold) | Max. 8.5 A (max. Temperature 85 °C / 185 F) | | | | |
| Function module AZX61.1 for SA..61.. ⁹⁾ | Is supplied by the actuator. Function module AZX61.1 cannot be combined with SA..61../MO. | | | | |

- 1) Switching time for RMS of the sine wave at nominal voltage
- 2) SAL.T20 / T40 have a minimum holding torque of 14 Nm
- 3) Observe acting direction of DIL switches
- 4) AWG = American wire gauge
- 5) Also with weather shield ASK39.1
- 6) SA..61../MO are not suitable for outdoor applications.
- 7) Up to 150 °C with horizontal mounting position
- 8) The documents can be downloaded from <http://siemens.com/bt/download>.
- 9) UL recognized component 

6 Connection diagrams and dimensions

6.1 Internal diagrams

SA..31..

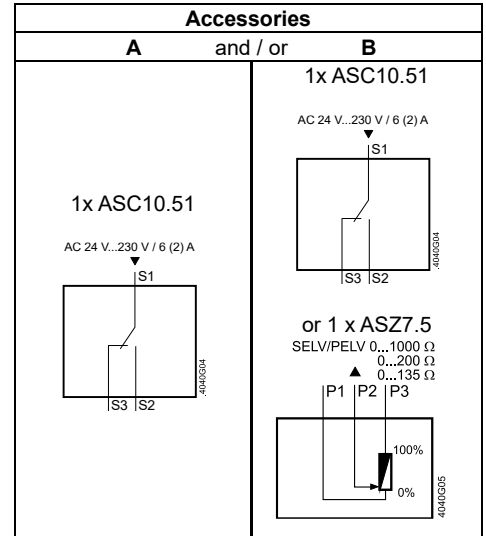
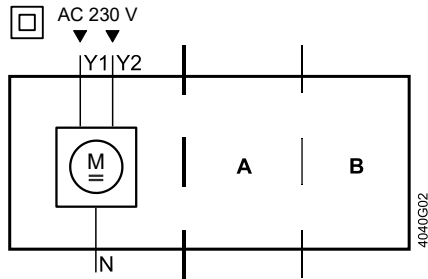

SA..61..

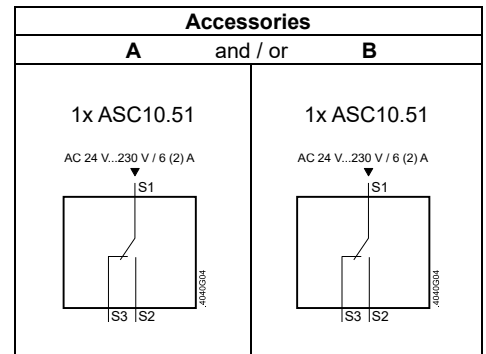
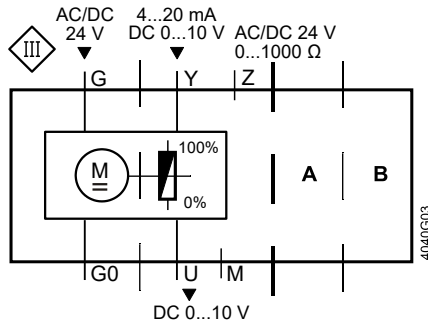

SA..61../MO

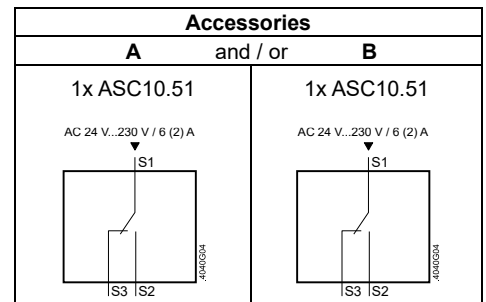
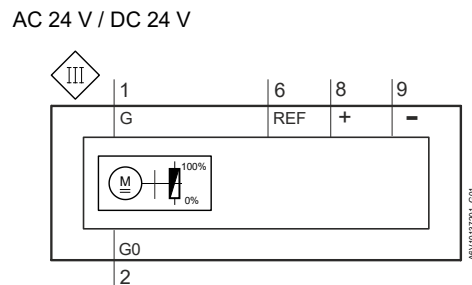

SA..81..

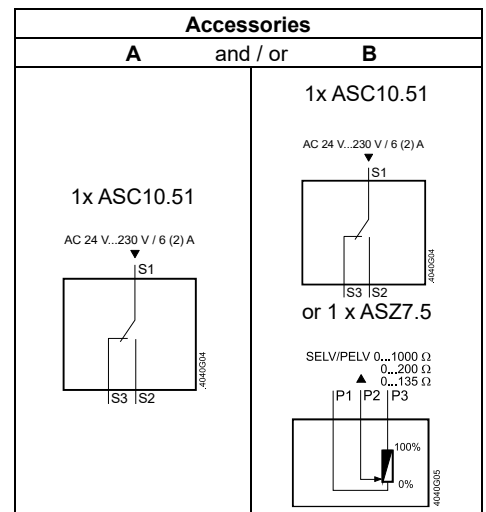
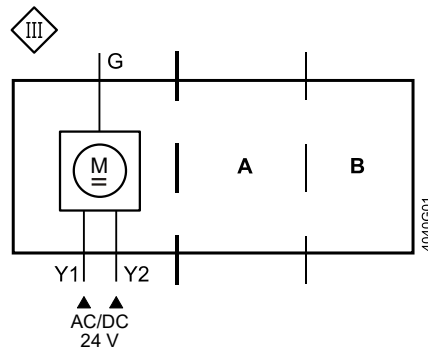

6.2 Connection terminals

6.2.1 Actuators

SA..31

AC 230 V, 3-position

| | |
|----|--|
| N | System neutral (SN) |
| Y1 | Positioning signal (actuator's stem extends / actuator's spindle turns clockwise) |
| Y2 | Positioning signal (actuator's stem retracts / actuator's spindle turns counter-clockwise) |

SA..31P

AC 230 V, 3-position

| | |
|----|---|
| N | System neutral (SN) |
| Y1 | Positioning signal (actuator's stem retracts) |
| Y2 | Positioning signal (actuator's stem extends) |

SA..61..

AC/DC 24 V, DC 0...10 V / 4...20 mA / 0...1000 Ω

| | |
|----|--|
| G0 | System neutral (SN) |
| G | System potential (SP) |
| Y | Positioning signal for DC 0...10 V / 4...20 mA |
| M | Measuring neutral |
| U | Position feedback DC 0...10 V - (reference potential is M measuring neutral) |
| Z | Positioning signal forced control AC/DC ≤ 24 V, 0...1000 Ω |

SA..61../MO

Fixed connecting cable
5 x 0.75 mm²

AC/DC 24 V, Modbus RTU connection cable

| | | |
|-----|---|--------|
| G0 | System neutral (SN) | black |
| G | System potential (SP) AC 24 V ~ / DC 24 V = | red |
| REF | Reference (Modbus RTU) | violet |
| + | Bus + (Modbus RTU) | grey |
| - | Bus - (Modbus RTU) | pink |

SA..81

AC/DC 24 V, 3-position

| | |
|----|--|
| G | System potential (SP) |
| Y1 | Positioning signal (actuator's stem extends / actuator's spindle turns clockwise) |
| Y2 | Positioning signal (actuator's stem retracts / actuator's spindle turns counter-clockwise) |

SA..81P

AC/DC 24 V, 3-position

| | |
|----|---|
| G | System potential (SP) |
| Y1 | Positioning signal (actuator's stem retracts) |
| Y2 | Positioning signal (actuator's stem extends) |

6.2.2 Electrical accessories

Auxiliary switch ASC10.51

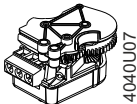

Adjustable switching points, AC 24...230 V

| | |
|---|-----------------------|
| 1 | System potential (SP) |
| 2 | Closing Contact |
| 3 | Opening Contact |

Switching state allway's related to extending actuator stem or clockwise turning actuator's spindle turns

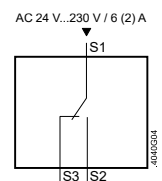

Potentiometer ASZ7.5

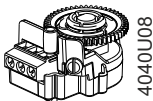

Adjustment of zero point, DC 10 V

| | |
|---|-------------------|
| 1 | Measuring neutral |
| 2 | 0...x Ω |
| 3 | x...0 Ω |

x = 135 Ω, 200 Ω, 1000 Ω

First, observe "Notes on ASZ7.5" (page 21).

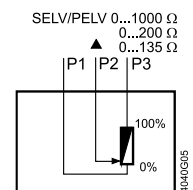

**Stem heating element
ASZ6.6**

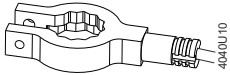

AC/DC 24 V / 30 W / 50 VA / inrush current max. 8.5 A

- 1 System neutral (SN) (red)
- 2 System potential (SP) (black)

6.3 Connection diagrams

SA..31..

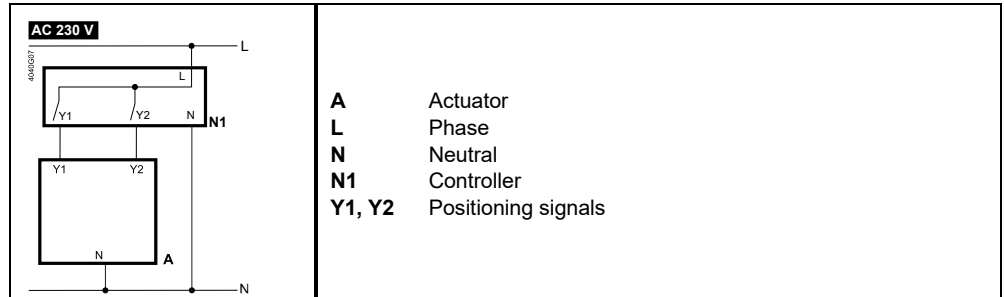

SA..61..

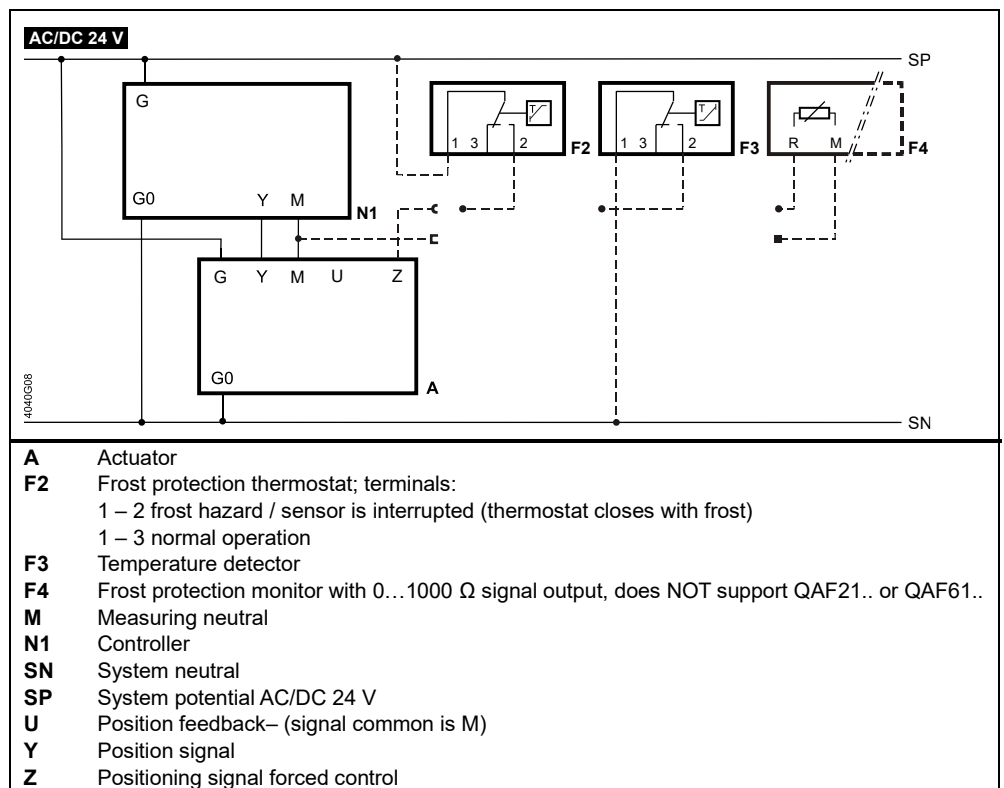

SA..61../MO

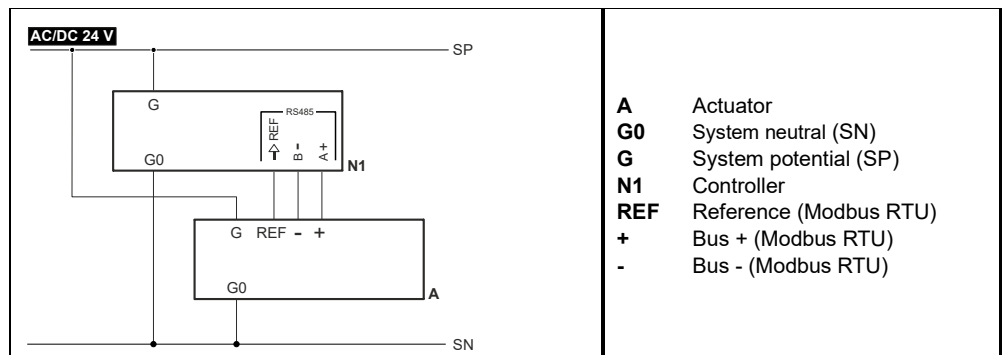

SA..81..

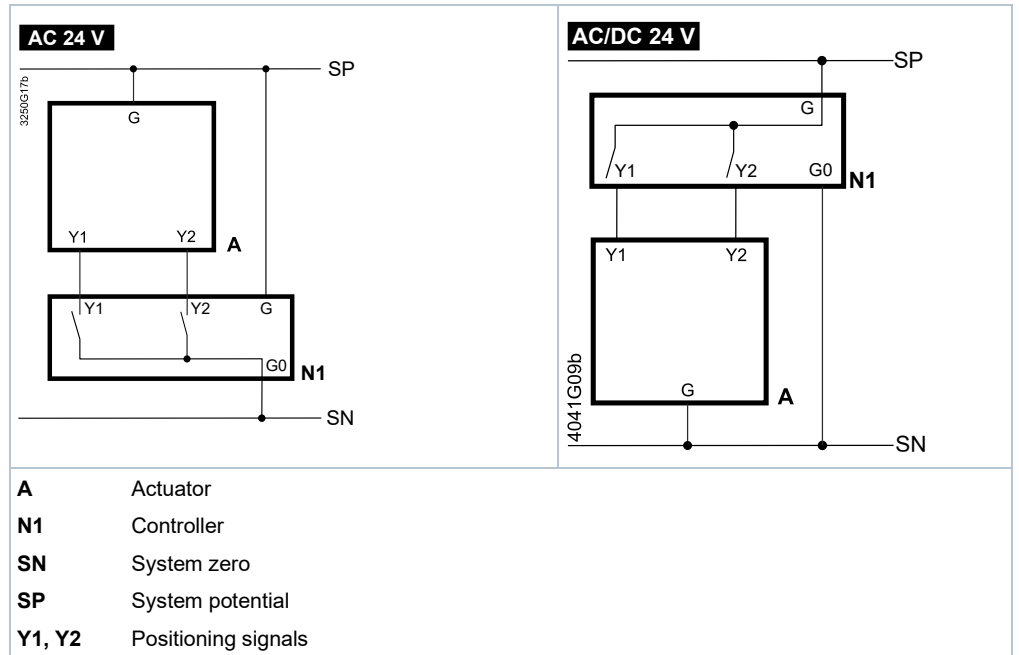

6.4 Dimensions

6.4.1 Stroke actuators

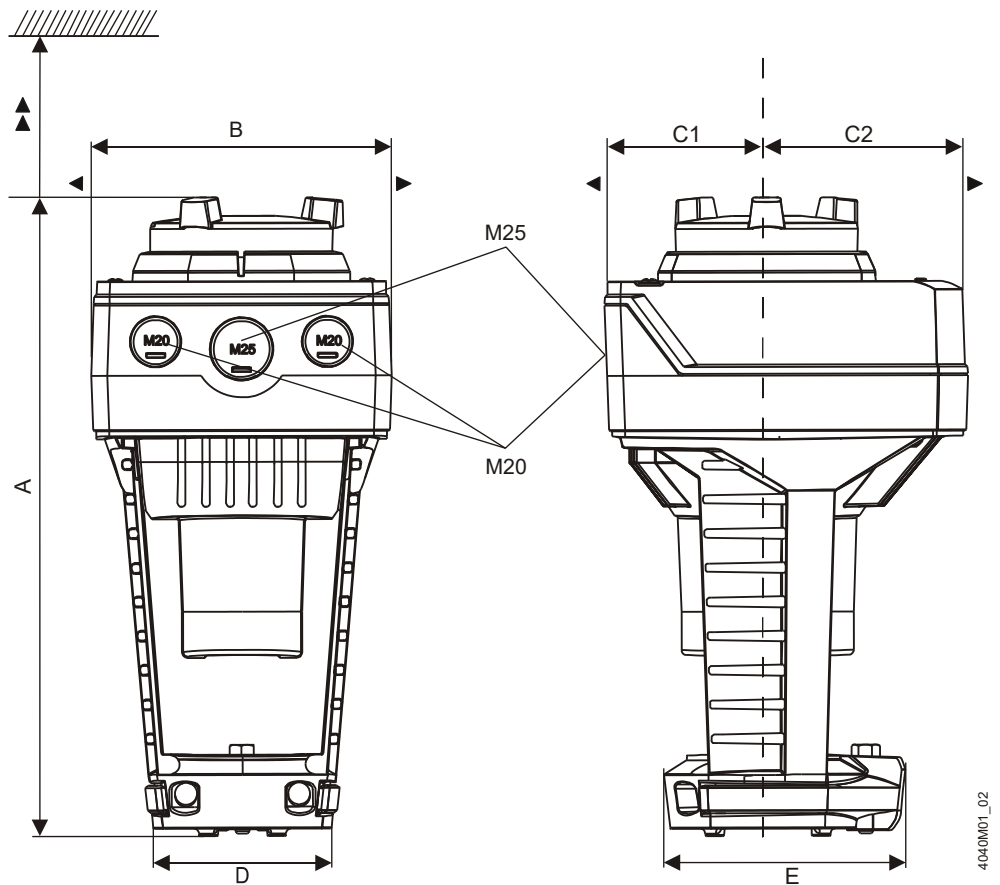

4040W01_02

- 1 SAX../SAV..: M25
 SAX../SAV..U: ½" (Ø 21.5 mm)
 2 SAX../SAV..: M20
 SAX../SAV..U: ½" (Ø 21.5 mm)

| Type | A | B | C | C1 | C2 | D | E | ▶ | ▶▶ | kg |
|--------------------------|-----|-----|-----|-----|-----|----|-----|-----|-----|-------|
| SAX.. (U ¹⁾) | 242 | 124 | 150 | 68 | 82 | 80 | 100 | 100 | 200 | 1.780 |
| SAX../MO ³⁾ | | | | | | | | | | 1.930 |
| Mit ASK39.1 | +25 | 154 | 300 | 200 | 100 | - | - | - | - | 2.010 |
| SAV.. (U ¹⁾) | 265 | 124 | 150 | 68 | 82 | 80 | 100 | 100 | 200 | 1.920 |
| SAV../MO | | | | | | | | | | 2.070 |
| Mit ASK39.1 | +25 | 154 | 300 | 200 | 100 | - | - | - | - | 2.150 |
| SAY.. (U ¹⁾) | 242 | 124 | 150 | 68 | 82 | 80 | 100 | 100 | 200 | 1.780 |
| SAY../MO | | | | | | | | | | 1.930 |

¹⁾ SAX..U: 1.850 kg

²⁾ SAY..U: 1.850 kg

³⁾ Device equipped with a fixed connection cable – Left cable entry is used

Dimensions in mm

6.4.2 External Modbus converter

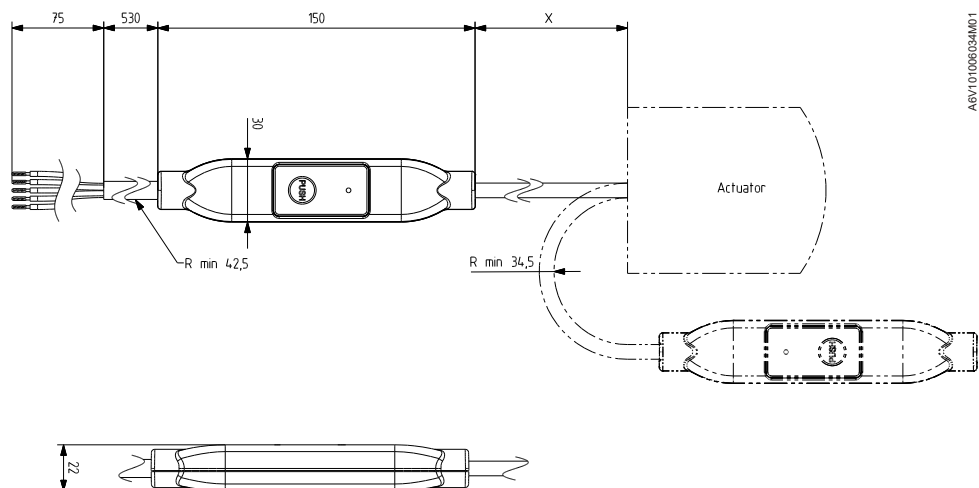

ASV101008034M01

| Type | X [mm] | kg [kg] |
|---------|-----------|--------------------|
| SA../MO | 250 | 0.15 ¹⁾ |

¹⁾ Already included in total weight

Dimensions in mm

6.4.3 Rotary actuators

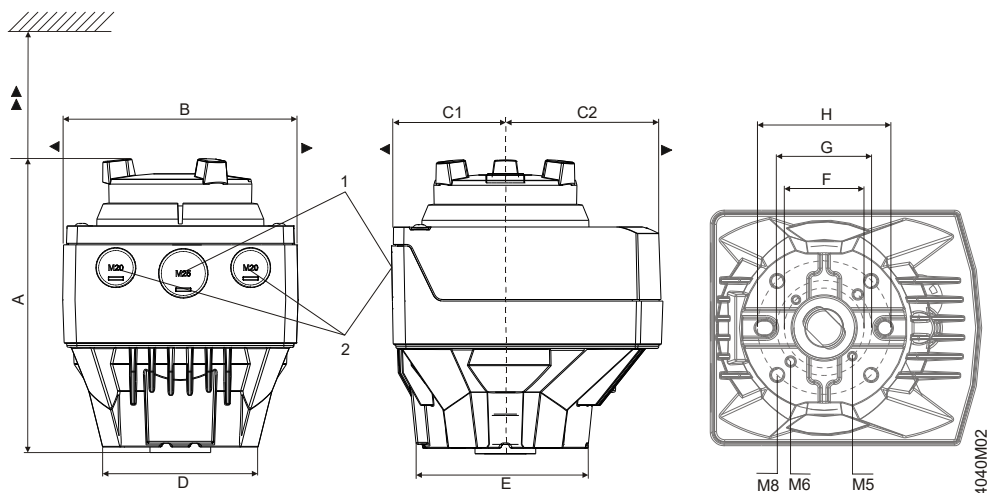

- 1 SAL...: M25
- 2 SAL...: M20

| Typ | A | B | C | C1 | C2 | D | E | F | G | H | ▶ | ▶▶ | kg | | |
|--------------|-----|-----|-----|-----|-----|----|----|----|----|----|-----|-----|-----------|----------|----------|
| | | | | | | | | | | | | | SAL..T10 | SAL..T20 | SAL..T40 |
| SAL.. | 160 | 124 | 150 | 68 | 82 | 82 | 88 | 42 | 50 | 70 | 100 | 200 | 1.475 | 1.600 | 1.625 |
| With ASK39.1 | +25 | 154 | 300 | 200 | 100 | - | - | - | - | - | - | - | 1.710 | 1.835 | 1.860 |

**With mounting set
ASK3..N**

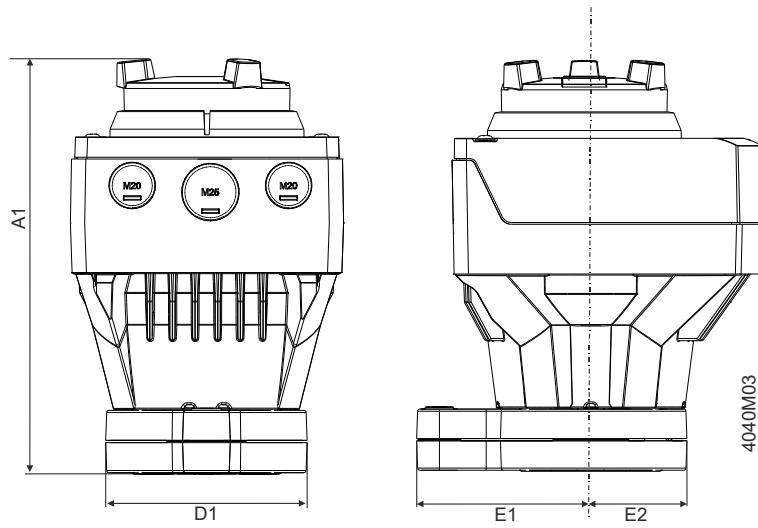

| Type | A1 | D1 | E1 | E2 |
|---------------------------|-----|----|----|----|
| SAL.. with ASK3..N | 188 | 88 | 80 | 44 |
| With ASK39.1 | +25 | - | - | - |

Dimensions in mm

7 Revision numbers

| Product no. | Valid from rev. no. | Product no. | Valid from rev. no. |
|-------------|---------------------|-----------------|---------------------|
| SAX31.00 | ..K | SAL31.00T10 | ..F |
| SAX31.03 | ..K | SAL31.00T20 | ..E |
| SAX31P03 | ..K | SAL31.00T40 | ..C |
| SAX81.00 | ..H | SAL31.03T10 | ..F |
| SAX81.03 | ..H | SAL31.03T10/F05 | ..A |
| SAX81.03U | ..H | SAL61.00T10 | ..E |
| SAX81P03 | ..H | SAL61.00T20 | ..D |
| SAX61.03 | ..H | SAL81.00T40 | ..B |
| SAX61.03U | ..H | SAL61.03T10 | ..E |
| SAX61P03 | ..H | SAL61.03T10/F05 | ..A |
| SAX61.03/MO | ..C | SAL81.00T10 | ..E |
| SAX61P03/MO | ..B | SAL81.00T20 | ..D |
| | | SAL81.00T40 | ..B |
| SAV31.00 | ..C | SAL81.03T10 | ..E |
| SAV61.00 | ..B | SAL81.03T10/F05 | ..A |
| SAV61.00U | ..B | | |
| SAV61P00 | ..D | SAY31P03 | ..B |
| SAV81.00 | ..B | SAY61P03 | ..A |
| SAV81.00U | ..B | SAY81P03 | ..A |
| SAV81P00 | ..B | SAY61P03/MO | ..A |
| SAV61.00/MO | ..A | | |
| SAV61P00/MO | ..A | | |

8 Glossary

8.1 Symbols



Caution, general danger – read the notes!



Caution, hot surface – read the notes!



Condition as supplied to customer



Crosstip screwdriver (Pozidriv)



Slotted screwdriver



Screw wrench



Allen key

8.2 Terms

Climatix™

The complete product range of flexible and scalable control solutions, standardized up to and including freely programmable solutions. Specialized for HVAC applications.

DIL switches

A DIL switch shows the switching choices in the form of a place value system (dual in line) in relation to basis 2 (on and off).

DN

Nominal size: Characteristic for matching parts of the piping system.

Forced control

Forced control serves for overriding automatic mode and is implemented in the structure.

HEX switches

A HEX switch shows the switching choices in the form of a place value system (hexadecimal system) in relation to basis 16 (0...9 and A...F).

kPa

Unit of pressure: 100 kPa = 1 bar = 10 mWS.

k_{vs}

Nominal flow rate: Nominal flow rate of cold water (5...30 °C) through the fully open valve (H_{100}) at a differential pressure of 100 kPa (1 bar).

LED

Light emitting diode.

Modbus RTU

Open communications protocol (client/server architecture), transmits data as binary data.
RTU: Remote Terminal Unit.

PN

PN class: Characteristic relating to the combination of mechanical und dimensional properties of a component in the piping system.

Position feedback

Signal used to acquire the position, fed back via an input.

Spring return facility

Refer "fail safe function".

$\Delta p_{max} / \Delta p_{maxV}$

Maximum permissible differential pressure across the valve's control path, valid for the entire actuating range of the motorized valve ($V =$ diverting mode).

Δp_s

Maximum permissible differential pressure at which the motorized valve will close securely against the pressure (close off pressure).

slotted screwdriver

Index

| | | | |
|-------------------------------------|--|-------------------------------------|------------------------|
| 3-position control | 56 | Directives | 82 |
| A/D conversion..... | 56, 59 | Disposal..... | 55 |
| About this documentation | 5 | DN..... | 15, 17, 20 |
| Accessories..... | 21, 82 | Document use | 9 |
| Electrical accessories..... | 21 | Electrical accessories..... | 78 |
| Mechanical accessories | 22 | Electrical planners | 9 |
| Acting direction | 61, 63 | Engineering | 10 |
| Angular rotation..... | 12 | Environmental compatibility..... | 82 |
| Anschlussklemmen | | Environmental conditions | 82 |
| Stetig | 84 | Equipment combinations | 15 |
| Auxiliary switch ASC10.51 | 21, 40, 43, 48, 51, 54, 55, 78, 82, 83, 84 | 2-port valves..... | 17 |
| Before you start..... | 8 | 3-port valves..... | 15 |
| Brushless DC motor..... | 56, 59 | combi valves | 19 |
| Cable entries..... | 81 | slipper and butterfly valves | 20 |
| Cable glands | 10, 47 | Extra functions..... | 11, 12 |
| Cable lengths..... | 25 | Flow characteristic..... | 62, 63, 78 |
| Calibration..... | 49, 59, 65, 70 | Equal-percentage..... | 62, 63 |
| Calibration slot..... | 40, 59 | Linear | 62, 63 |
| Changeover of acting direction..... | 61 | Flow characteristic selection | 11, 62 |
| Changeover of characteristic..... | 59 | Force | 15 |
| Characteristics function | 59 | Forced control..... | 11, 12, 59, 68, 81 |
| Commissioning | 49 | Formulas for wire lengths | 26 |
| Connecting cable | 81 | Function check | 49 |
| Connection diagrams..... | 83, 85 | Function data..... | 81 |
| Connection terminals | 40, 84 | Function description | 73 |
| 3-position | 84 | Function module AZX61.1 | 21, 40, 42, 59, 60, 79 |
| Actuators | 84 | Function principle | 75 |
| Auxiliary switch ASC10.51..... | 84 | Functions | 56 |
| Electrical accessories..... | 84 | Gear train..... | 56, 59 |
| Modulating..... | 84 | Glossary | 91 |
| Potentiometer ASZ7.5..... | 84 | Handling | 27 |
| Stem heating element ASZ6.6 | 85 | HEX switches | 60 |
| Contents..... | 3 | Housing cover..... | 10 |
| Control | 56 | HVAC plants | 9 |
| Control functions | 56 | Identification of seat..... | 56, 59 |
| Control functions | 59 | Indicators | 77 |
| Control of direction..... | 56 | LED | 77 |
| Copyright..... | 8 | Operational status indication..... | 77 |
| Coupling..... | 10, 76 | Position indication | 77 |
| Cross-sectional area of wire | 26 | Status indication..... | 77 |
| cross-sectional areas..... | 25 | Indoor use..... | 27 |
| Degree of protection | 82 | Installation | 10, 27, 46 |
| Delivery | 13 | Interior view | 40 |
| Detection of foreign bodies | 59, 67, 69 | Internal diagrams..... | 83 |
| Detection of valve seat | 66 | k_{vs} | 15, 17, 20 |
| Deviations | 57 | L/P-diagram | 26 |
| DIL switches..... | 40, 59, 60, 61 | LED..... | 11, 12, 40, 59, 77 |
| Dimensions | 82, 87, 88 | Maintenance | 52, 55 |
| Modbus converter..... | 88 | Manual adjuster | 10, 11, 12, 56, 59, 76 |
| Rotary actuators | 88 | Automatic | 76 |
| Stroke actuators | 87 | Disengaging the fixing..... | 76 |
| Direct acting | 61, 63 | Fixing the coupling | 76 |
| | | Manual operation | 76 |

| | | | |
|--|--------------------|--------------------------------------|--------------------|
| Manual adjustment | 56, 59, 70 | Product replacements | 22 |
| Mechanical accessories | 79 | Quality assurance..... | 9 |
| Modbus RTU..... | 52 | Quick access | 5 |
| External converter | 53 | Reference documents | 8 |
| Modulating control | 59 | Request to the reader..... | 9 |
| Motor control..... | 56, 59 | Reverse acting | 61, 63 |
| Mounting | 27 | Revision history | 7 |
| Accessories..... | 40 | Revision numbers..... | 90 |
| Auxiliary switch ASC10.51 | 43 | Scope of this document..... | 9 |
| Fitting actuators to butterfly valves. 29, 34, 35, 37, 38, 39 | | Selecting the acting direction | 61 |
| Fitting actuators to seat valves..... | 27 | Sequence control | 60 |
| Fitting actuators to slipper valves..... | 31 | Setting elements..... | 40 |
| Function module AZX61.1 | 42 | Signal adaptation..... | 60 |
| Mounting positions | 27 | Signal error..... | 25 |
| Potentiometer ASZ7.5 | 41 | Signal inputs..... | 81 |
| Stem heating element ASZ6.6 | 45 | Signal priorities..... | 66 |
| Weather shield ASK39.1 | 46 | Sizing..... | 25 |
| Mounting set ASK3..N..... | 20, 79, 89 | Spare parts..... | 24 |
| Mounting set ASK31N..... | 22, 31 | Spring return time..... | 11, 12 |
| Mounting set ASK33N..... | 22, 29 | Standards | 82 |
| Mounting set ASK35N..... | 22, 35 | Status indication | 10 |
| Navigation..... | 5 | Stem heating element ASZ6.6 | 21, 45, 79, 82, 85 |
| Operating voltage | 26, 81 | Stroke | 11, 12 |
| Operating voltage | 11, 12 | Supported function codes | 73 |
| Ordering | 13 | Symbols..... | 91 |
| Outdoor use | 27 | Technical | 75 |
| Parallel operation..... | 81 | Technical data | 80 |
| Parallel operation of actuators | 25 | Technical design..... | 68 |
| Parameters | 71 | Technology | 68 |
| Permissible voltage drop | 26 | Terms..... | 91 |
| Permissible wire length..... | 26 | Torque | 12, 20, 23 |
| Plug-in space A..... | 40, 41, 43 | Trademarks | 8 |
| Plug-in space B..... | 40, 42, 44 | Transmission of power | 75 |
| PN..... | 15, 17, 20 | Type summary..... | 11 |
| Position control | 59 | Rotary actuators..... | 12 |
| Position feedback | 11, 12, 62, 81 | Stroke actuators..... | 11 |
| Position indication..... | 10 | Use | 11 |
| Positioning force | 11, 12, 15, 17, 22 | User interface | 10 |
| Positioning signal..... | 11, 12, 59 | Valve neck coupling..... | 10 |
| Positioning signal (Z) | 81 | Valve seat detection | 68 |
| Positioning signal selection | 62 | Valve stem coupling | 10 |
| Positioning time | 11, 12, 22 | Voltage drop | 25 |
| Positioning times stroke model..... | 57 | Volumetric flow | 61, 62 |
| Potentiometer ASZ7.5..... | 21, 40, 41, 51, 78 | Warranty | 26 |
| Potentiometer ASZ7.5. | 48, 82, 83, 84 | Weather shield ASK39.1 | 22, 46, 79 |
| Power consumption | 26 | Weight | 82 |
| Power supply | 59, 81 | Wiring | 46 |
| Power transmission | 10 | Actuator..... | 47 |
| Product description..... | 10 | Auxiliary switch ASC10.51 | 48, 51 |
| Product replacements | | Potentiometer ASZ7.5..... | 48 |
| Electrical accessories..... | 23 | Preparation of wire endings | 46 |
| Rotary actuators SQL.. to SAL..... | 23 | Yoke..... | 10 |
| Stroke actuators SQX.. to SAX..... | 22 | Δp_{max} | 15, 17, 20 |
| | | Δp_s | 17, 20 |

Issued by
Siemens Switzerland Ltd
Smart Infrastructure
Global Headquarters
Theilerstrasse 1a
6300 Zug
Switzerland
Tel. +41 58-724 24 24
www.siemens.com/sbt

© Siemens Switzerland Ltd, 2010 - 2024
Technical specifications and availability subject to change without notice