

SIEMENS



SAS31.03



SAS61.53



SAS61.33



SAS61.03/MO

Acvatix™ Actuators SAS..., SAT.. for valves Basic Documentation

Siemens Switzerland Ltd
Smart Infrastructure
Global Headquarters
Theilerstrasse 1a
6300 Zug
Switzerland
Phone +41 58-724 24 24
www.siemens.com/buildingtechnologies

© Siemens Switzerland Ltd, 2019
Technical specifications and availability subject to change without notice.

Contents

1	About this documentation	5
1.1	Navigation	5
1.2	Revision history	5
1.3	Reference documents	5
1.4	Before you start	6
1.4.1	Trademarks	6
1.4.2	Copyright	6
1.4.3	Quality assurance	6
1.4.4	Document use / request to the reader	7
1.5	Scope of this documentation	7
2	Engineering	8
2.1	Product description	8
2.2	Use	9
2.3	Type summary	9
2.3.1	Stroke actuators	9
2.4	Ordering	10
2.5	Equipment combinations	11
2.5.1	2-port / 3-port threaded valves with stroke actuator SAS	11
2.5.2	2-port / 3-port threaded valves with stroke actuator SAS.. and SAT	11
2.6	Accessories	12
2.6.1	Electrical accessories	12
2.6.2	Mechanical accessories	12
2.7	Product replacements	12
2.7.1	Stroke actuators SAS../SAT.. to SQS	13
2.7.2	Electrical accessories	13
2.8	Spare parts	13
2.9	Sizing	14
2.9.1	Parallel operation of actuators	14
2.9.2	Permissible cable length and wire cross-sectional area	14
2.10	Warranty	15
3	Handling	16
3.1	Mounting and installation	16
3.1.1	Mounting positions	16
3.1.2	Fitting stroke actuators SAS.. to threaded valves	16
3.1.3	Accessories	18
3.1.4	Wiring (installation)	22
3.2	Commissioning and operation	26
3.2.1	Function check and Calibration	26
3.2.2	Commissioning Modbus RTU	28
3.2.3	Maintenance	32
3.2.4	Disposal	32
4	Functions and control	33
4.1	3-position control	33
4.1.1	Combination with RVD.. controllers for direct domestic hot water distribution by heat exchanger	35
4.2	Modulating control	36
4.2.1	Positioning signal and flow characteristic selection	38

4.2.2	Position feedback U	39
4.2.3	Calibration	39
4.2.4	Signal priorities.....	40
4.2.5	Detection of valve seat.....	41
4.2.6	Detection of foreign bodies	41
4.2.7	Forced control Z.....	42
4.3	Communicating actuators Modbus RTU	42
4.3.1	Detection of valve seat.....	42
4.3.2	Detection of foreign bodies	43
4.3.3	Calibration	43
4.3.4	Manual adjustment.....	44
4.3.5	Parameters and function description	45
4.4	Technical and mechanical design	48
4.4.1	Transmission of power	48
4.4.2	Kopplung	48
4.4.3	Fail safe function	48
4.4.4	Manual adjuster.....	49
4.4.5	Indicators.....	50
4.4.6	Electrical accessories.....	51
4.4.7	Mechanical accessories	51
5	Technical data.....	52
6	Connection diagrams and dimensions	55
6.1	Internal diagrams	55
6.2	Connection terminals	57
6.2.1	Actuators	57
6.2.2	Electrical accessories.....	58
6.2.3	Cable labeling	58
6.3	Connection diagrams	59
6.4	Dimensions.....	62
6.4.1	Stroke actuators	62
6.4.2	External Modbus Converter	64
	Revision numbers	64
7	Glossary	65
7.1	Symbols.....	65
7.2	Terms.....	65
8	Index	67

1 About this documentation

1.1 Navigation

Information about a specific actuator is provided throughout the document. The structure of chapters 2 to 4 is as follows:

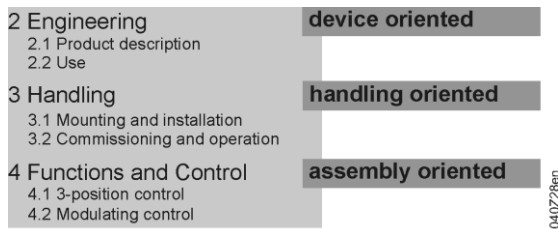

Note

Glossary and Index are arranged at the end of the document.

1.2 Revision history

Revision	Date	Changes	Chapter
First edition	2015-05-19	-	-
2.0	2016-02-26	Corrections in: Technical Data, Equipment Combinations, use of vocabulary, Mounting Position, Connection Diagrams	2; 3; 4; 5
2.1	2017-05-08	New: Communicating actuators (SAS61.03/MO)	Title image, 2, 3.1.1, 3.2.2, 4.3, 5, 6, 7
		Supplement: Adapter set ASK30	3.1.3, 4.4.7
		Modified: Connection terminals, disposal, positioning time stroke model	3.1.4, 3.2.3, 4.1
2.2	2019-04-09	New: Combination with RVD.. controllers	4.1.1
2.3	2022-05-19	Introduction Modbus types	various
		Comment stepless drive removed	4.2
		Adaptation: Connection terminals"	6.2
		Adaption: Connection diagrams	6.3
		Various changes	various
2.4	2024-01-11	Various pictures replaced (better quality) LED-status "dark" implemented Connection diagram SA..61../MO rectified accessory number ASK39.2 rectified	various 3.2.2 6.3 various

1.3 Reference documents

Type of document	SAS..	SAT..
Data sheet	N4581	N4584
Data sheet, communications profile Modbus	A6V101037195	-
Mounting Instructions	lasered on cover	
Mounting instructions S..6../MO and G..161../MO	A5W00027551	-
CE Declaration of Conformity (AC 230 V, AC/DC 24 V)	CE1T4581xx	CE1T4584xx
RCM Declaration of Conformity	CE1T4581en_C1	CE1T4584en_C1
Environmental Declaration	E4581	E4584
Environmental declaration, external Modbus converter	A6V101083254	-

1.4 Before you start

1.4.1 Trademarks

The table below lists the third-party trademarks used in this document and their legal owners. The use of trademarks is subject to international and domestic provisions of the law.

Trademarks	Legal owner
Acvatix™	Siemens Switzerland Ltd

All product names listed in the table are registered (®) or not registered (™) trademarks of the owner listed in the table. We forgo the labeling (e.g. using the symbols ® and ™) of trademarks for the purposes of legibility based on the reference in this section.

1.4.2 Copyright

This document may be duplicated and distributed only with the express permission of Siemens, and may be passed on only to authorized persons or companies with the required technical knowledge.

1.4.3 Quality assurance

These documents were prepared with great care.

- The contents of all documents are checked at regular intervals
- All necessary corrections are included in subsequent versions
- Anpassungen bzw. Documents are automatically amended as a consequence of modifications and corrections to the products described

Please make sure that you are aware of the latest document revision date.

If you find lack of clarity while using this document, or if you have any criticisms or suggestions, please contact the product manager in your nearest branch office.

The addresses of the Siemens regional companies are available at

www.siemens.com/acvatix.

1.4.4 Document use / request to the reader

Before using our products, it is important that you read the documents supplied with or ordered at the same time as the products (equipment, applications, tools etc.) carefully and in full.

We assume that persons using our products and documents are authorized and trained appropriately and have the technical knowledge required to use our products as intended.

More information on the products and applications is available:

- On the intranet (Siemens employees only) at <https://workspace.sbt.siemens.com/content/00001123/default.aspx>.
- From the Siemens branch office near you www.siemens.com/acvatix or from your system supplier.
- From the support team at headquarters fieldsupport-zug.ch.sbt@siemens.com if there is no local point of contact.

Siemens assumes no liability to the extent allowed under the law for any losses resulting from a failure to comply with the aforementioned points or for the improper compliance of the same.

1.5 Scope of this documentation

This document shall serve as a source of knowledge. In addition to basic information, it provides general technical information about the actuators used in HVAC plants. It is also targeted at engineering staff, HVAC electrical planners, system integrators and service engineers and provides all information required for planning work, correct installation, commissioning and service.

2 Engineering

2.1 Product description

The line of small actuators is comprised of stroke actuators SAS.. and SAT..

Mechanical design

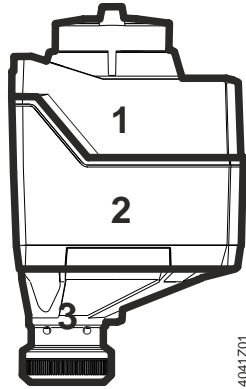

SAS.., SAT..

1	User interface Electrical connections
2	Power transmission and preparation Print Motor
3	Yoke (for assembly of actuator and seat, slipper valve)

Components

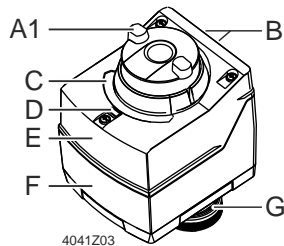

SAS.. / SAT..

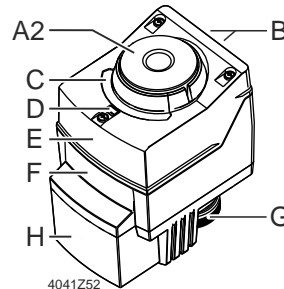

SAS..5.. / SAT..5..

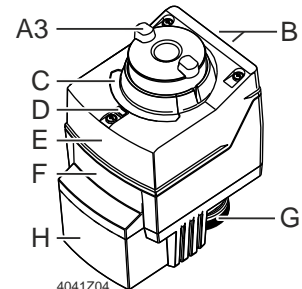

SAS..33..

- A1** Manual adjuster (with slide switch)
- A2** Dummy cover (without manual adjuster)
- A3** Manual adjuster (without slide switch)
- B** Cable glands (M16 / M20)
- C** Position indication
- D** Status indication (SA..61.., 0...10 V)
- E** Housing cover
- F** Housing
- G** Valve stem coupling
- H** Housing of spring return

Network functions

See Section 3.2.2 Commissioning Modbus RTU

2.2 Use

SAS.. / SAT..

For use in connection with Siemens 2-port or 3-port valves, as control or shutoff valves for HVAC plants.

2.3 Type summary

2.3.1 Stroke actuators

- All types:
- Stroke 5.5 mm
 - Positioning force SAS.. 400 N
SAT.. 300 N

Product no.	Stock no.	Operating voltage	Positioning signal	Power consumption	Positioning time	Fail safe function / Spring return time	Manual adjuster ⁸⁾	Position feedback	Remark
SAS31.00	S55158-A106	AC 230 V	3-position	2.8 / 2.4 VA ⁵⁾	120 s	no / –	yes	-	1) 3)
SAS31.03	S55158-A107			3.5 / 2.9 VA ⁵⁾	30 s				
SAS31.50	S55158-A108			3.5 / 2.9 VA ⁵⁾	120 s	yes / <28 s ⁶⁾	no		
SAS31.53	S55158-A109			5.5 / 3.8 VA ⁵⁾	30 s	yes / <14 s ⁶⁾			
SAS61.03	S55158-A100	AC/DC 24 V	DC 0...10 V	5.3 / 4.5 VA ⁵⁾	30 s	no / –	yes	DC 0...10 V	1)
SAS61.03U	S55158-A100-A100		DC 4...20 mA 0...1000 Ω	5.3 / 4.5 VA ⁵⁾				2)	
SAS61.03/MO	S55158-A121		Modbus RTU	6.0 / 5.2 VA ⁵⁾		1), 7)			
SAS61.33	S55158-A101		DC 0...10 V	5.9 / 4.8 VA ⁵⁾		1)			
SAS61.33U	S55158-A101-A100		DC 4...20 mA 0...1000 Ω	5.9 / 4.8 VA ⁵⁾		2)			
SAS61.33/MO	S55158-A122		Modbus RTU	6,6 / 5,5 VA ⁵⁾		1), 7)			
SAS61.53	S55158-A102	DC 0...10 V	5.8 / 5.0 VA ⁵⁾	1)	4)				
SAS81.00	S55158-A103	AC/DC 24 V	3-position	2.2 / 2.0 VA ⁵⁾	120 s	no / –	yes	-	1)
SAS81.03	S55158-A104			2.5 / 2.1 VA ⁵⁾	30 s				1)
SAS81.03U	S55158-A104-A100			2.5 / 2.1 VA ⁵⁾					2)
SAS81.33	S55158-A105			3.4 / 2.4 VA ⁵⁾	yes / <14 s ⁶⁾	1)			
SAS81.33U	S55158-A105-A100			3.4 / 2.4 VA ⁵⁾		2)			
SAT31.008	S55158-A119	AC 230 V	3-position	5.0 / 2.5 VA ⁵⁾	8 s	no / –	yes	-	3)
SAT31.51	S55158-A120			5.5 / 3.2 VA ⁵⁾	15 s	yes / <8 s ⁶⁾	no		
SAT61.008	S55158-A117	AC/DC 24 V	DC 0...10 V	7.1 / 4.6 VA ⁵⁾	8 s	no / –	yes	DC 0...10 V	1) 4)
SAT61.008/MO	S55158-A123		Modbus RTU	6.4 / 4.8 VA ⁵⁾	15 s	yes / <8 s ⁶⁾	no	Modbus RTU	
SAT61.51	S55158-A118		DC 0...10 V					Modbus RTU	
SAT61.51/MO	S55158-A124		Modbus RTU						

- 1) Cable gland: M16 and M20 (ISO50262)
- 2) Cable gland: ½" (UL514C)
- 3) Approbation: CE
- 4) Approbation: CE and UL (only 24 V)
- 5) Second value: Power consumption in neutral position
- 6) Spring return time increased slightly at low temperatures
- 7) Fixed connection cable 5 x 0.75 mm²
- 8) Not designed for continuous operation.

2.4 Ordering

Example

Product no.	Stock no.	Description	Quantity
SAS31.00	S55158-A106	Actuator	1
+ auxiliary components (connections, auxiliary switches...)			

Delivery

Actuators, valves and accessories are supplied in individual packs.

2.5 Equipment combinations

2.5.1 2-port / 3-port threaded valves with stroke actuator SAS..

Typical applications:



- Heating plants
- District heating plants
- Ventilation and air conditioning plants

Actuators

Stroke
Positioning force
Data sheet

SAS..

5.5 mm
400 N
N4581

PN 16	VVG44..	PN 16	VVG44..	SAS..				
				Medium	1...120 °C	Medium	1...120 °C	DN
Data sheet	N4364	Data sheet	N4464		[Inch]	[m ³ /h]	[kPa]	[kPa]
	VVG44.15-.. ¹⁾		VVG44.15-.. ¹⁾	15	G 1 B	0.25 / 0.4 / 0.63	400	1600
	VVG44.15-.. ¹⁾		VVG44.15-.. ¹⁾	15	G 1 B	1 / 1.6	400	725
	VVG44.15-.. ¹⁾		VVG44.15-.. ¹⁾	15	G 1 B	2.5 / 4	400	400
	VVG44.20-6.3		VVG44.20-6.3	20	G 1 1/4 B	6.3	400	750
	VVG44.25-10		VVG44.25-10	25	G 1 1/2 B	10	400	400
	VVG44.32-16		VVG44.32-16	32	G 2 B	16	250	250
	VVG44.40-25		VVG44.40-25	40	G 2 1/4 B	25	125	125

PN 25	VVG55.. ²⁾	SAS..				
		Medium	1...130 °C	DN	G	k _{vs}
Data sheet	N4379		[Inch]	[m ³ /h]	[kPa]	[kPa]
	VVG55.15-.. ¹⁾	15	G 3/4 B	0.25 / 0.4 / 0.63	1200	2500
	VVG55.15-.. ¹⁾	15	G 3/4 B	1 / 1.6 / 2.5	1200	2000
	VVG55.20-4	20	G 1 B	4	1000	1000
	VVG55.25-6.3	25	G 1 1/4 B	6.3	800	800

¹⁾ .. = insert k_{vs} value

²⁾ .. = VVG55 to be replaced by VVG549 as of January 1, 2017

2.5.2 2-port / 3-port threaded valves with stroke actuator SAS.. and SAT..

Typical applications:

- District heating plants

Actuators

Stroke
Positioning force
Data sheet

SAS..

5.5 mm
400 N
N4581

SAT..

5.5 mm
300 N
N4584

PN 25	VVG549..	SAS.. ^{1), 2)}				SAT.. ¹⁾						
		Medium	2...130 °C	DN	G	k _{vs}	Δp _{max}	Δp _s				
Data sheet	Q4380		[Zoll]	[m ³ /h]	[kPa]	[kPa]	[kPa]	[kPa]				
	VVG549.15-0.25	15	G 3/4 B	0,25	1200	2500	1200	2500				
	VVG549.15-0.4			0,4								
	VVG549.15-0.63			0,63								
	VVG549.15-1			1								
	VVG549.15-1.6			1,6								
	VVG549.15-2.5			2,5								
	VVG549.20-4K ³⁾			20					G 1 B	4	1600	1600
	VVG549.25-6.3K ³⁾			25					G 1 1/4 B	6,3		

¹⁾ Briefly 150 °C (up to 150 °C max. 6 of 24 hours), with ALG..B fittings up to 100 °C

²⁾ SAS.. combined with VVG549: Change setting on the DIL switch to linear (factory setting = log).

SA../MO: Change Modbus register 263 to 0 = linear → only possible with Firmware release 2.0, not with 0.27 and 1.0!

³⁾ Pressure compensated

2.6 Accessories

2.6.1 Electrical accessories

Product no.	Accessory	Description
SAS.. / SAT..	ASC10.51	Auxiliary switch

2.6.2 Mechanical accessories

Product no.	Accessory	Description
SAS.. / SAT..	ASK39.2	Weather shield
SAS..	ASK30 ²⁾	Adapter set

¹⁾ SA..61../MO is not suitable for outdoor applications

²⁾ All ex-Landis & Gyr valves with a 4 mm or 5.5 mm strokes can be used with the adapterset: X3i.., VVG45.., VXG45.., VXG46.., VVI51...

2.7 Product replacements

Replacement of SQS../SSC.. actuators by SAS.. and SAT.. actuators.

Note

- When replacing actuators consider positioning force.
- Adjust in the controller the parameter "Running time" (corresponds to positioning time + idle stroke) and "Positioning time" if changed, to ensure stable control.
- The replacement of accessory items needs to be taken into consideration also. In that case, compatibility is not necessarily ensured.

2.7.1 Stroke actuators SAS../SAT.. to SQS..

SQS..		Pos. time [s]	Pos. force [N]	SAS.. / SAT..		Pos. time [s]	Pos. force [N]	VVG44..	VVG44..	VVG55..	VVG55..	VVG549..	VVG549..
Product no.	OEM			Product no.	Pos. time [s]			Pos. force [N]	DN15...40	DN15...25	DN15...25	DN15...25	DN15...25
SQS35.00	SQS359.00/189	150	400	SAS31.00	120	400	✓	✓	-				
	SQS35.000C						✓	✓	-				
	SQS35.00SL						✓	✓	-				
SQS35.03	SQS359.03	35		SAS31.03	30		✓	✓	-				
	SQS359.03/189			✓	✓		-						
SQS35.50	-	150		SAS31.50	120		✓	✓	-				
SQS35.53	-	35	SAS31.53	30	✓	✓	-						
-	SQS359.05	15	250	SAT31.008	8	300	-	-	✓				
-	SQS359.54	20	400	SAT31.51	15		-	-	✓				
SQS65	-	150	400	SAS61.03	30	400	✓	✓	-				
SQS65.2	-	35		-			✓	✓	-				
SQS65.5	-			SAS61.53			✓	✓	-				
SQS65.5U ¹⁾	-			SAS61.33U			✓	✓	-				
SQS65U ¹⁾	-			SAS61.03U			✓	✓	-				
SQS85.00	-			150			SAS81.00	120	✓	✓	-		
SQS85.03	-		35	SAS81.03	30	✓	✓	-					
SQS85.53U ¹⁾	-	SAS81.33U		✓		✓	-						

¹⁾ SQS..U: prepared for ½ inch flex conduit connection; SAS..U with ½ inch

2.7.2 Electrical accessories

Notes

- If auxiliary switches are used, their switching points should be indicated on the plant schematic.
- Do not insulate the yoke and housing of the actuator and the valve stem, as air circulation must be ensured.
- **Non-observance of the above may result in accidents and fires!**
- **Do not touch the hot parts without prior protective measures to avoid burns!**



Stroke actuators		SQS..	SAS..
ASC9.6	Auxiliary switch	ASC9.6	ASC10.51

2.8 Spare parts

The following spare parts are available:

SAS..
SAT..

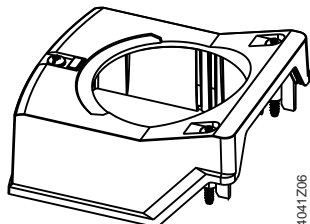
Stock number	Description	
S55845-Z180	Type ASQ1: Housing cover with screws and light conductor as an assembly, without laser marking	

2.9 Sizing

2.9.1 Parallel operation of actuators

SAS31.. and SAS81..

3-position actuators must have one specific controller each; refer to chapter 6.3 Connection diagrams (page 59).

SAS61..

Up to 10 actuators can drive in parallel on a controller output with a rating of 1 mA. Modulating actuators have an input impedance of 100 kΩ.

2.9.2 Permissible cable length and wire cross-sectional area

Cable lengths and wire cross-sectional areas depend on the following criteria of the actuators:

- Current draw
- Permissible voltage drop across the power supply lines

The control accuracy of the modulating actuators can be improved by using 4-wire connections, thus ensuring that voltage drops on G0 will not distort the positioning signal.

Note

When determining the cable length and the wire cross-sectional area, adherence to the permissible operating voltage tolerance at the actuator is of importance, in addition to the permissible voltage drop across the operating voltage and signal lines (see table below).

Product no.	Operating voltage	Terminal	Max. permissible voltage drop
SA..31..	AC 230 V	N, Y1, Y2	2% each (total of 4%)
SA..61..	AC/DC 24 V	G0, Y, U	1% each (at DC 0...10 V)
SA..81..		G, Y1, Y2	4% each (total of 8%)

The following criteria must be considered:

- With modulating control, the permissible positioning signal error must not exceed 1%, the reason being the voltage drop on the G0 wire.
- The voltage drop, caused by charging current peaks in the actuator's DC circuit, must not exceed 2 Vpp.
- If the G0 line is not correctly sized, load changes of the actuator due to changes of the DC voltage drop might lead to self-oscillations.
- The operating voltage drop at AC/DC 24 V may be a maximum of 8% (4% across the G0 wire).

Basic diagram – voltage drop across the power supply cables

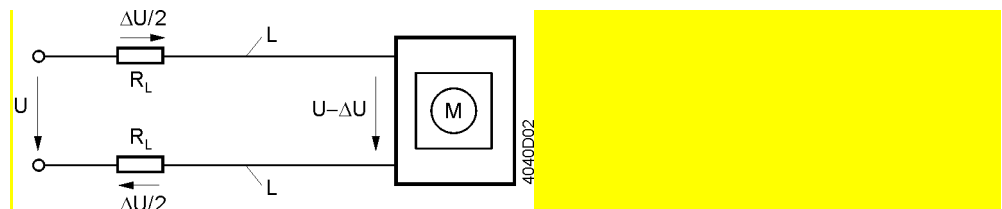

The following diagram can be used to determine the cable lengths and wire cross-sectional areas.

L/P-diagram for AC/DC 24 V

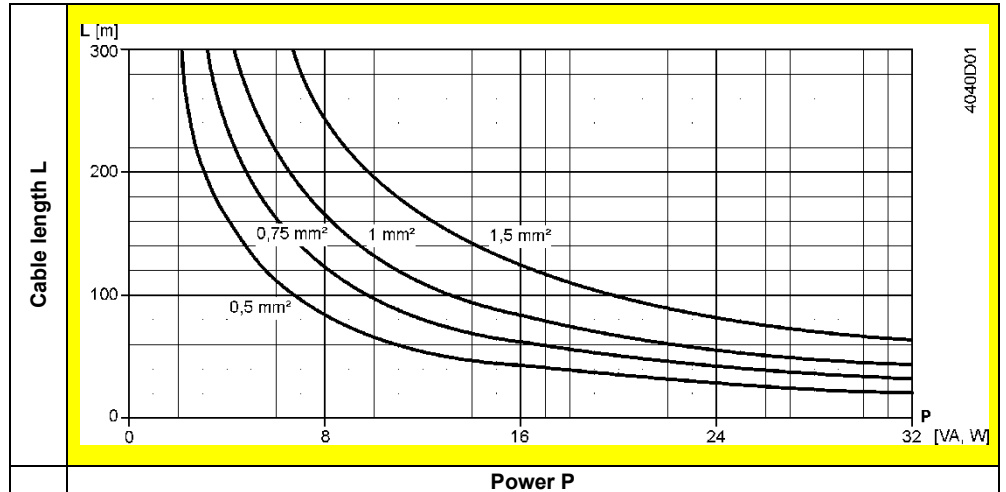

Permissible cable length L as a function of power P and cross-sectional area of wire as a parameter

Note

P is the decisive power consumption of all actuators connected in parallel. When operating on AC 24 V, power consumption is in VA; when operating on DC 24 V, in W.

Formulas for wire lengths

Operating voltage	Permissible voltage drop / wire	Formula for wire length
AC 230 V	2 % of AC 230 V	$L = 46 \cdot \frac{1313 \cdot A}{P}$ [m]
AC 24 V	4 % of AC 24 V	$L = \frac{1313 \cdot A}{P}$ [m]
	1 % of DC 10 V	$L = \frac{5.47 \cdot A}{I(DC)}$ [m]

- A Cross-sectional area of wire in mm²
- L Permissible wire length in m
- P Power consumption in VA (AC) or W (DC) (see actuator's rating plate)
- I(DC) DC current part (in A) on G0 wire

2.10 Warranty

The engineering data specified in chapter 2.5 Equipment combinations (page 11) are only guaranteed in connection with the Siemens valves listed. Siemens rejects any and all warranties in the event that third-party products are used.

Note

When using the actuators in connection with valves of other manufacture, correct functioning must be ensured by the user, and Siemens will assume no responsibility.

3 Handling

3.1 Mounting and installation

3.1.1 Mounting positions

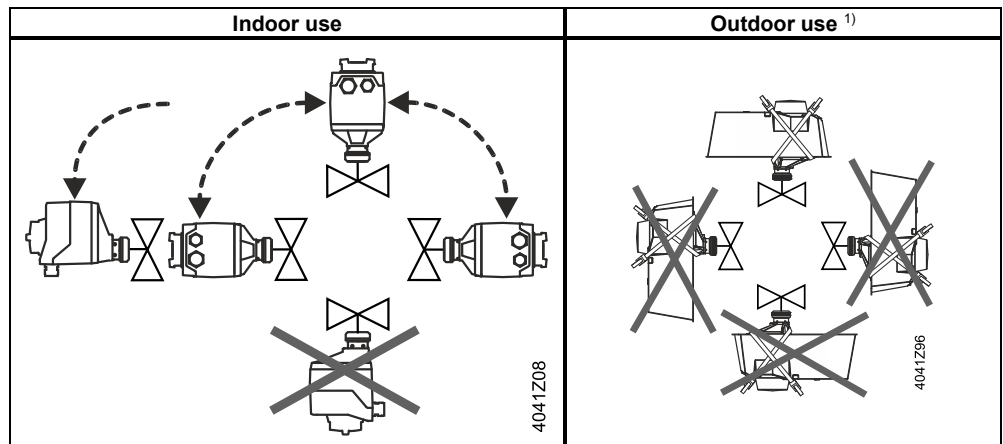

¹⁾ Only in connection with weather shield ASK39.2, housing protection IP54 remains unchanged
 SA..61../MO is not suitable for outdoor applications.

3.1.2 Fitting stroke actuators SAS.. to threaded valves

First, observe chapter 3.1.1 Mounting positions.

SAS..0..
 SAT..0..

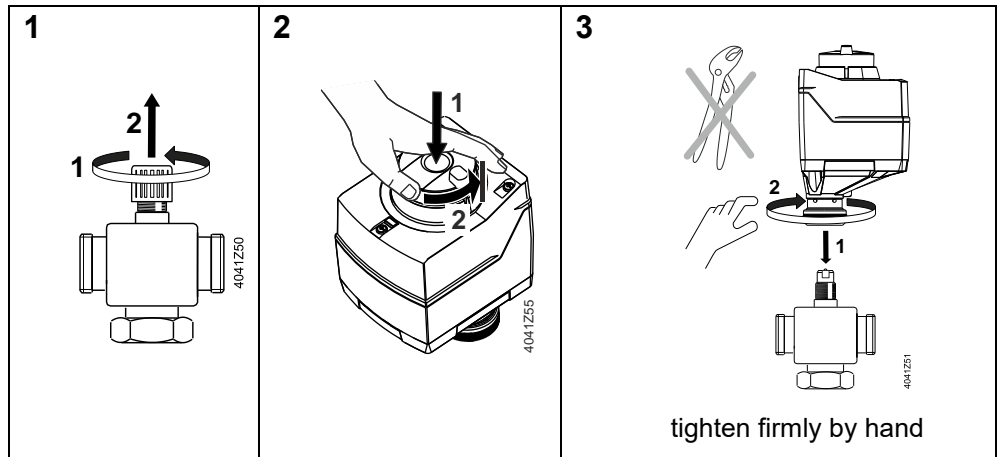

SAS..5..

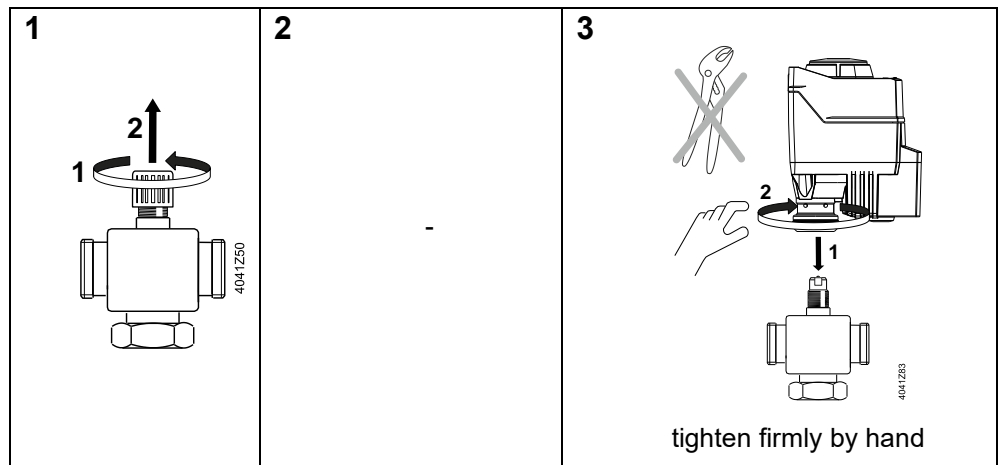

3.1.3 Accessories

Special notes on mounting

Before fitting the accessory items shown below, the following steps must be performed:

1. Actuator is mechanically connected to a Siemens valve.
2. Observe compatibility and choice of combinations. Refer to 2.6 (page 12).
3. Disconnect actuator, auxiliary switch from power.

Attention if AC 230 V connected danger of life!



4. Only required with actuators without fail safe function: Using the manual adjuster, drive the actuator's stem to the fully retracted position and fix the coupling. See "Manual operation" and "Fixing the position" (page 49).
5. To fit an auxiliary switch the housing cover must be removed and the M16 knock-out broken out.

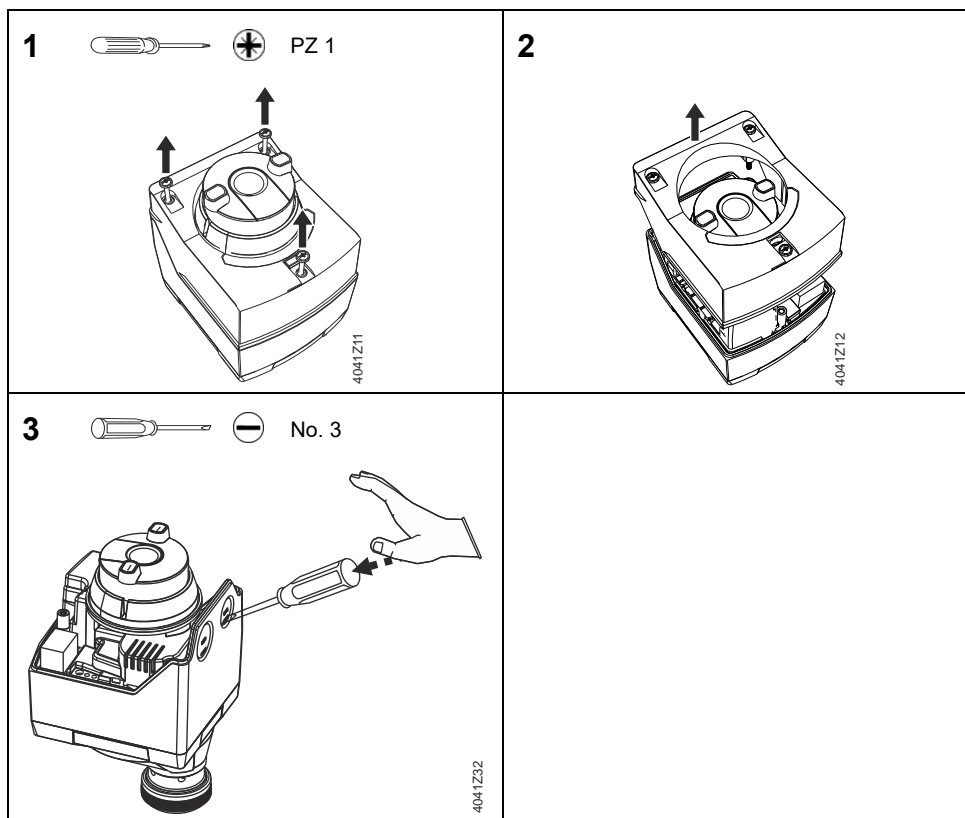

Interior view

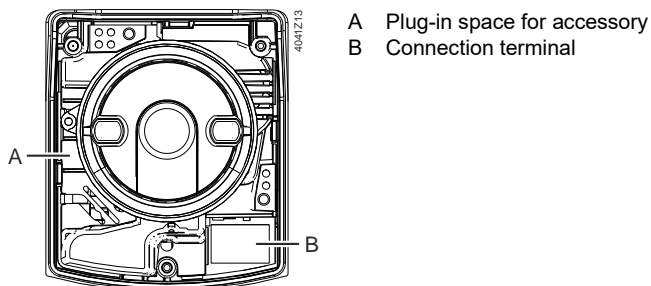

**Auxiliary switch
ASC10.51**

Scope of delivery

- 1 auxiliary switch
- 1 screw
- Cable ties

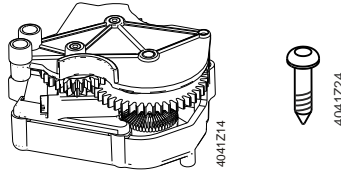

Plug-in space for
accessory

First, observe "Special notes on mounting" (page 18).

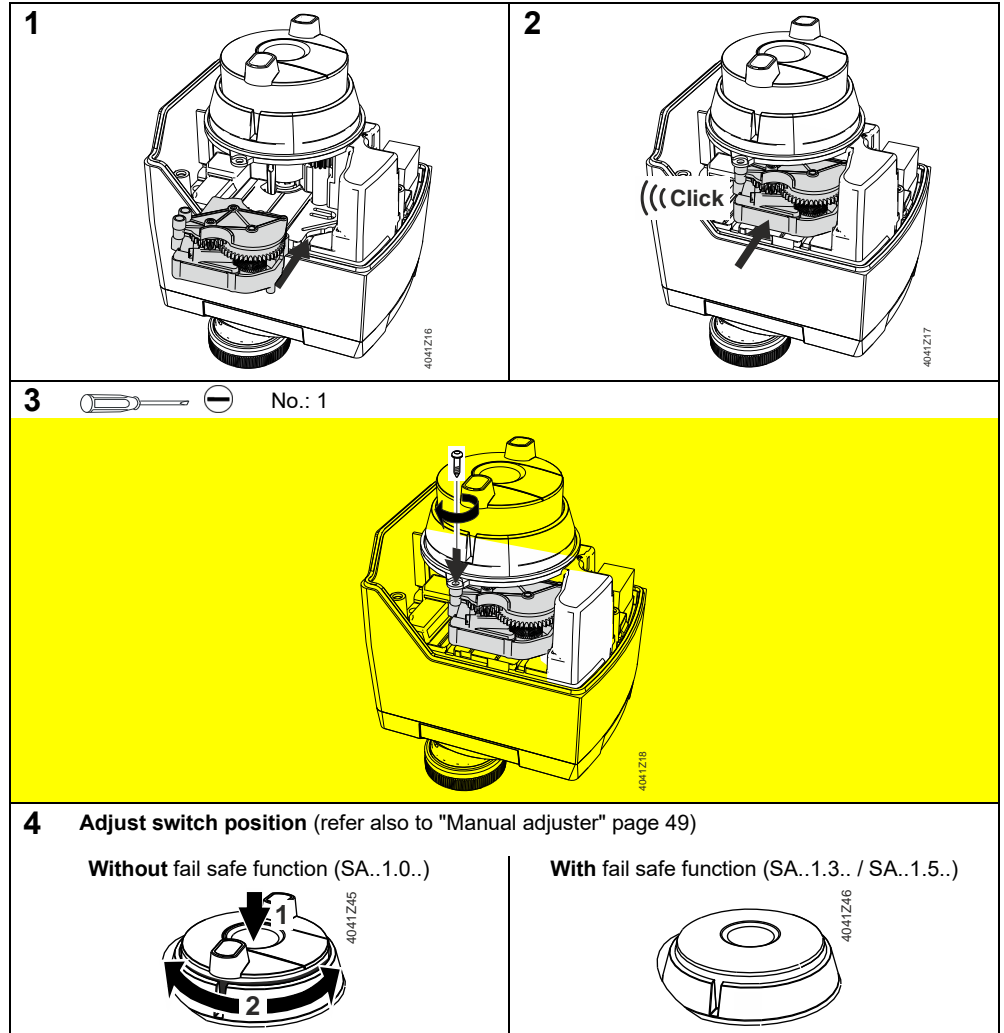

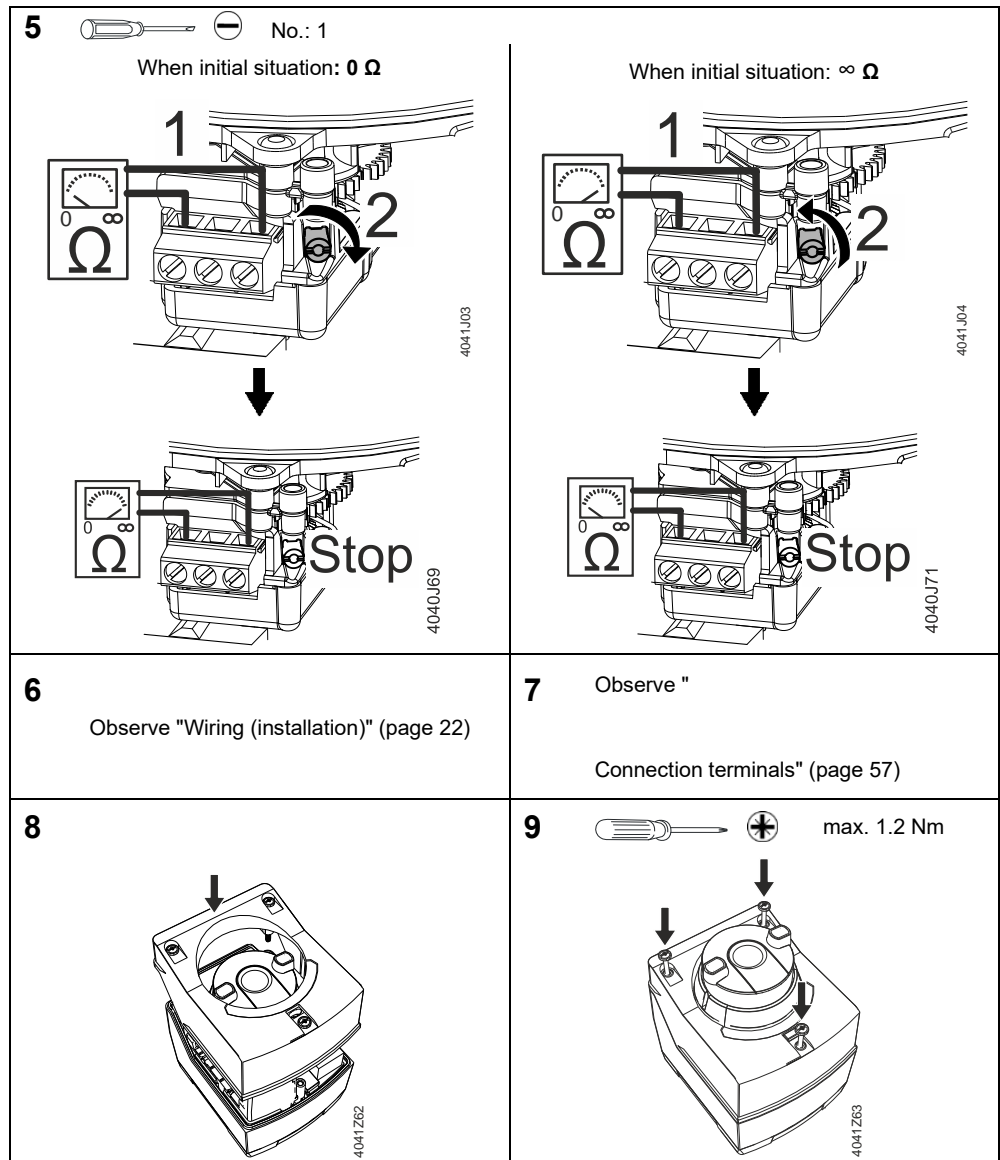

Note

Before commissioning with the control, check the exact position again; see "Auxiliary switch", page 28.

**Weather shield
ASK39.2**

First, observe "Special notes on mounting" (page 18).

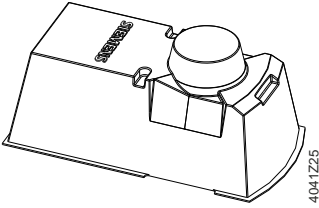
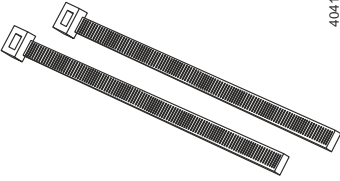
Scope of delivery	
Weather shield ASK39.2	2 UV-proof cable ties
 4041Z25	 4041Z26

Notes

- To protect the actuator from weather effects when used outdoors, the weather shield must always be fitted. The housing protection IP54 remains unchanged.
- If fitted several times, 2 UV-proof cable ties (700 x 7 mm) must be used when fitted again.
- The manual adjuster cannot be used when the weather shield is mounted.
- SA..61../MO is not suitable for outdoor applications.

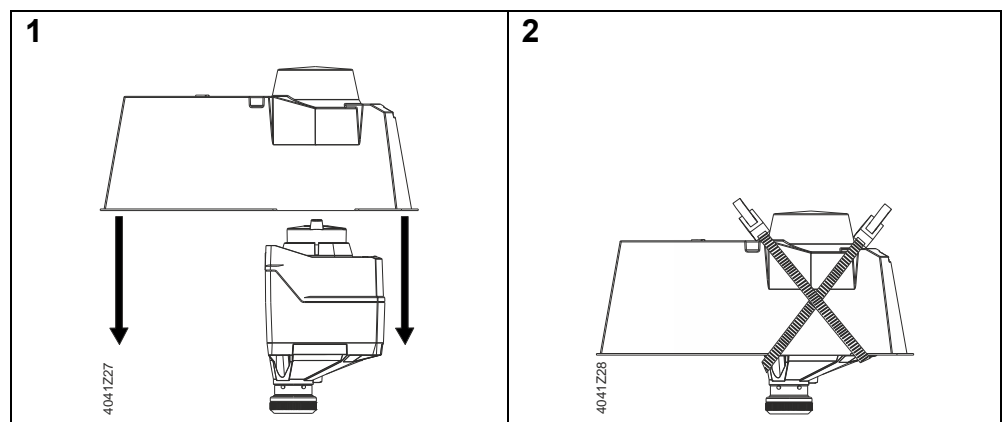

**Adapter set
ASK30**

Adapter set for ex-Landis & Gyr valves with 4 mm or 5.5 mm strokes:
X3i., VVG45., VXG45., VXG46., VVI51...

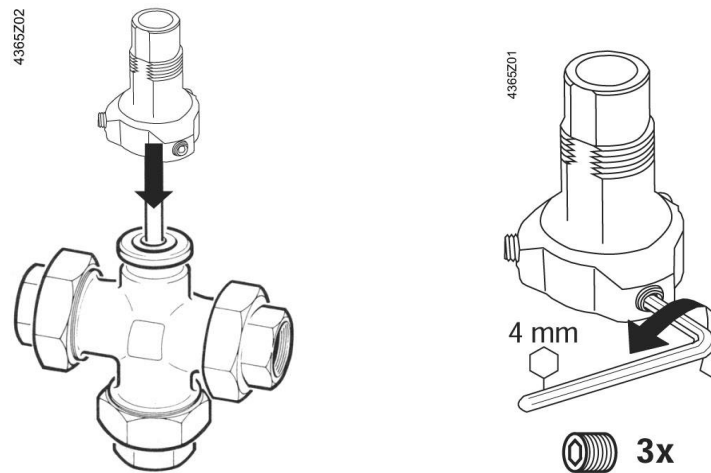

See Mounting instructions M4365.2

3.1.4 Wiring (installation)

Conduct the electrical connections in accordance with local regulations on electrical installations as well as chapter "

Connection terminals" on page 57.

Preparation of wire endings

The cable endings must be prepared before as follows:

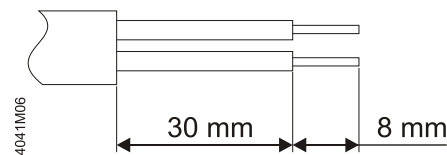

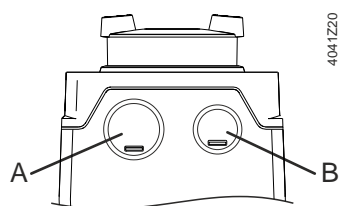

Cable entries

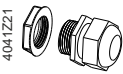
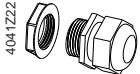

A	EU: M20 US: 1/2"	Connection actuator
B	EU: M16 US: 1/2"	Connection accessories

Cable glands

Cable glands (not contained in scope of delivery)		
Metric	Metric	Inch thread
M16	M20	1/2"
		

Notes

- Without cable gland IP protection is **not** guaranteed!
- Guide the cable in a loop to the cable gland, so water can drop off.

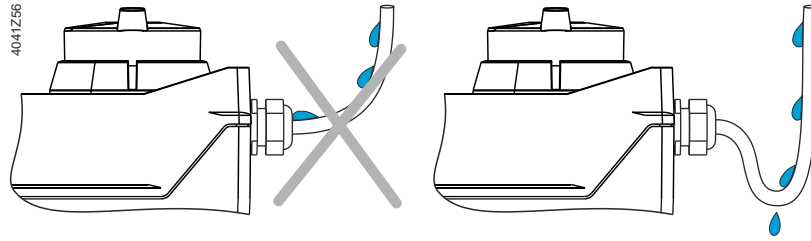

Preconditions

Prior to installation, the following preconditions must be satisfied:

- Actuator is mechanically connected to a Siemens valve.
- Housing cover is removed.



Communicating actuators

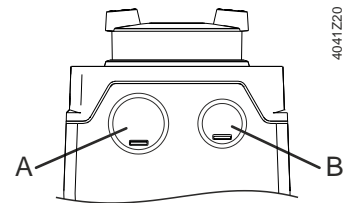

The actuator has a fixed connection cable. As a result, the left cable entry (A) is used.



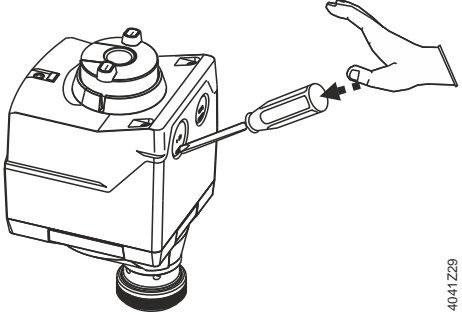

Actuator

1   No: 4



4041Z29

2   PZ 1

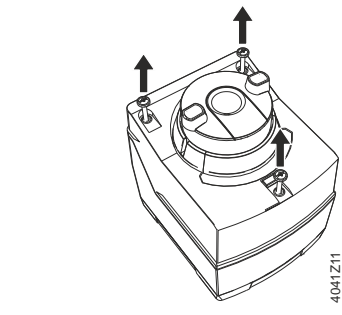

4041Z11

3

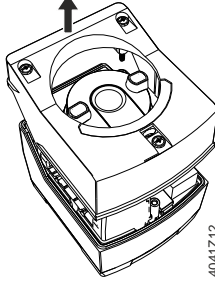

4041Z12

4

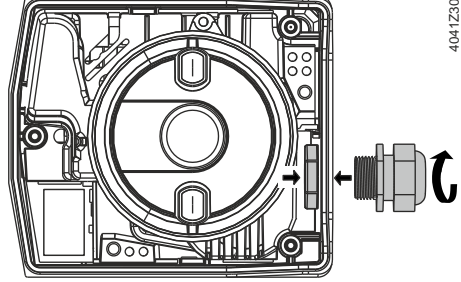

4041Z30

5

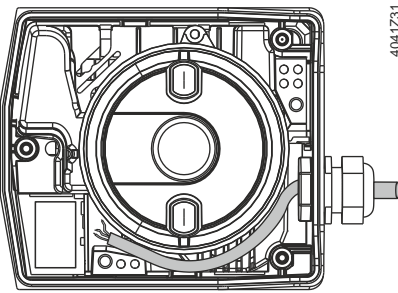

4041Z31

6 Observe "
Connection terminals" (page 57)

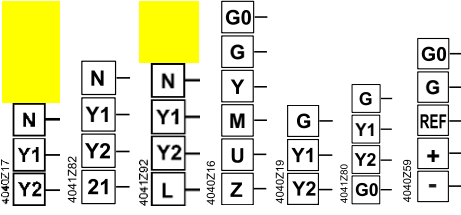

**Auxiliary switch
ASC10.51**

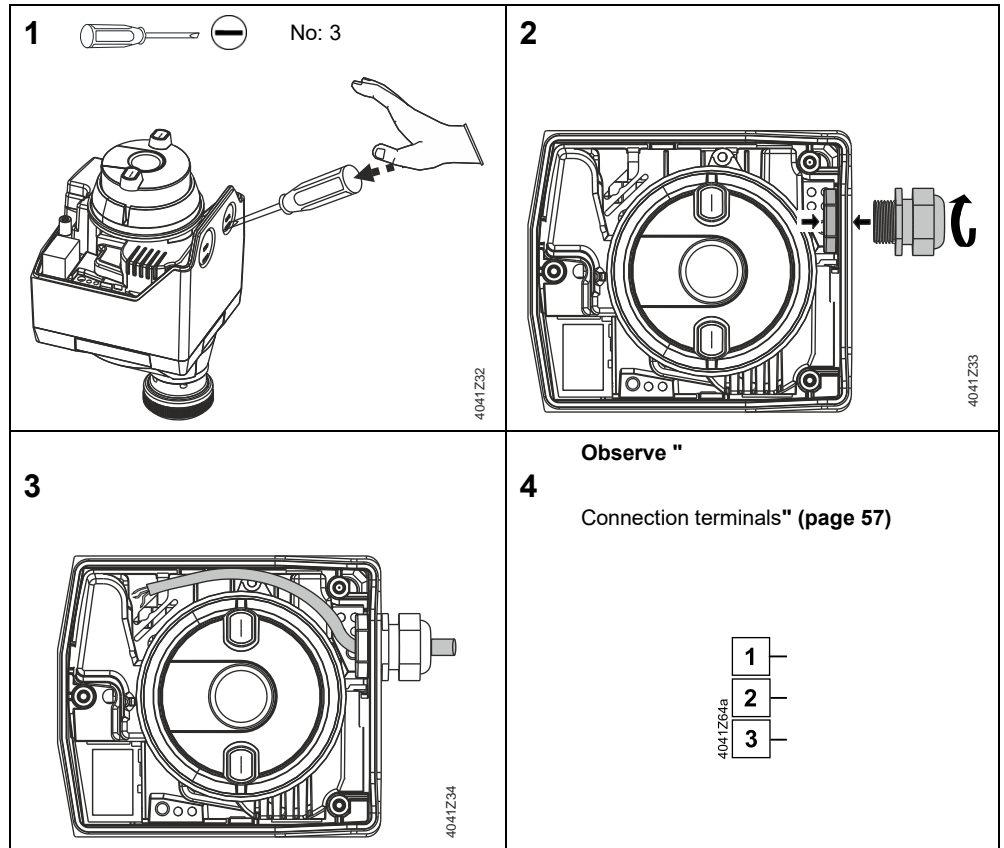
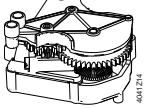

3.2 Commissioning and operation

3.2.1 Function check and Calibration

Manually



Before making the function check, the following preconditions must be satisfied:

- "Environmental conditions" specified in chapter "Technical data" (page 52)
- Actuator is mechanically connected to a Siemens valve.
- **Actuator is in "Manual operation" mode** (page 49).

If available, the actuator can be operated with the help of the "Manual adjuster" (see page 49).

Manual adjuster	Stroke actuator	Control path valve A → AB	Bypass valve B → AB
Turning in clockwise direction	Actuator's stem extends	Opening	Closing
Turning in counter-clockwise direction	Actuator's stem retracts	Closing	Opening

Notes

- If the actuator is forced to travel beyond its end positions, overload protection responds.
- Observe information given in chapter 4.2.1 Positioning signal and flow characteristic selection, page 38.

Electrically



Before making the function check, the following preconditions must be satisfied:

- "Environmental conditions" specified in chapter "Technical data" (page 52).
- Actuator is mechanically connected to a Siemens valve.
- **Actuator is in "Automatic" mode** (page 49).
- Actuator and, if required, accessories are correctly fitted and connected. Also refer to chapter
-
- Connection terminals" (page 57) .
- Power is applied.

SA..61..

Calibration is required with modulating actuators and SA..61.. before the function check.

General notes on calibration

Before making the calibration, the following preconditions must be satisfied:

- A description of the calibration function is given in chapter 4.2.3 Calibration (page 39).
- Housing cover is removed (see "Special notes on mounting", page 18).

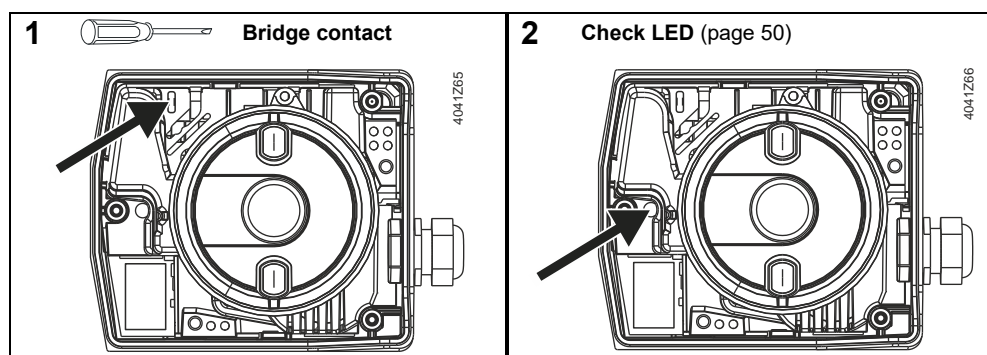

If required, calibration can be repeated any number of times.

Make the function check for modulating actuators after the calibration with a point test according to the following table:

Connection terminals	Stroke actuator		Control path valve A→AB	Bypass valveur B→AB	Position feedback U	
	log ²⁾	lin ²⁾			log ²⁾	lin ²⁾
Y 6 V 13.6 mA	Actuator's stem extends (30%)	Actuator's stem extends (60%)	Opening	Closing	2.95 V	6 V
Y 5 V 12 mA	Actuator's stem extends (23%)	Antriebsstößel fährt ein (50%)	Closing	Opening	2.3 V	5 V
Z connected G	Actuator's stem extends		Opening	Closing	10 V	10 V
Z connected to G0	Actuator's stem retracts		Closing	Opening	0 V	0 V
Only SAS61.33, SAS61.33U, SAS61.53, SAT61.51 No voltage at G and G0 (fail safe function triggers) ¹⁾	Actuator's stem retracts (until the end position is reached)		Schliesst	Öffnet	-	-

¹⁾ Closing action is always completed first, also when power returns.

²⁾ SAS61.. Factory setting **log**; SAT61.. factory setting **lin**

Make the function check for 3-position actuators according to the following table:

Connection terminals	Stroke actuator	Control path valve A → AB	Bypass valve B → AB
Voltage at Y1	Actuator's stem extends	Opening	Closing
Voltage at Y2	Actuator's stem retracts	Closing	Opening
No voltage at Y1 and Y2	Actuator's stem maintains the position	Maintains the position	
Only SAS31.50, SAS31.53, SAS81.33, SAS81.33U, SAT31.51 No voltage at G and G0 (fail safe function) ¹⁾	Actuator's stem retracts (until end position is reached)	Closing	Opening

¹⁾ Closing action is always completed first, also when power returns.

Note

Observe information given in chapter 4.2.1 Positioning signal and flow characteristic selection, page 38.

**Auxiliary switch
ASC10.51**

Make the function check of the mounted auxiliary switch with a point test according to the following table – example switching point at 25% position:

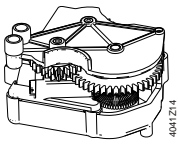

Connection terminals		Stroke actuator	Terminal S1 – S3	Terminal S1 – S2
Voltage at Y2	Y = 0 V	Actuator's stem retracts (until end position is reached)	-	-
No voltage at Y1 und Y2	Y = 0 V	Actuator's stem maintains the position		
Voltage at Y1 for desired valve position % + 2% x positioning time Example: SAS31.00 = 27 % x 120 sec = 32.5 sec	Valve position % + 2% Y = 2.7 V	Actuator's stem extends to desired position (27%)		
Check switching point with voltmeter		Actuator's stem maintains the position	-	-

3.2.2 Commissioning Modbus RTU

The devices were developed specifically for use with Climatix push-button configuration as described in document CE1A3975 ¹⁾.

As an alternative, the bus can be configured via the local HMI; see Section **User interface**, pg. 29.

Check the following during commissioning:

- Bus configuration (address, baud rate, type of transmission and optional termination). Standard address 255 allows for installation and commissioning of several actuators simultaneously without mutual interference.
- The actuator parameters (direction for opening, position limits, position adjustment etc.) can be read via the Modbus register.

¹⁾ Documents can be downloaded at <http://www.siemens.com/bt/download>

Full or partial configuration via bus

The actuators can be configured via bus connection if the settings prior to commissioning allow for a connection to the Modbus master/programming tool (no address conflicts and correct baud rates/transmission format settings).

- Full configuration via bus: With a unique Modbus address, a connection can be established from Modbus master/programming tool following startup by means of the preset transmission format and baud rate (or auto-baud).

- Partial configuration via bus: If the Modbus address is not unique, it must first be set to a unique value, either by using the address input with push button (cf. page 30) or by setting the address to 246 with push button press > 5s und < 10s (cf. page 29). Full configuration via bus: With a unique Modbus address, a connection can be established from Modbus master/programming tool following startup by means of the preset transmission format and baud rate (or auto-baud)..

With an existing connection, the bus and actuator parameters can be set to target values via the bus. During write access to the bus parameters, "1 = Load" must be written to register 768 within 30 seconds to ensure the changes are not discarded.

Example: The table shows the register values before and after the change via bus access.

Reg.	Name	Before change	After change
764	Modbus address	246	12
765	Baud rate	0 = auto	1 = 9600
766	Transmission format	0 = 1-8-E-1	3 = 1-8-N-2
767	Bus termination	0 = Off	0 = Off
768	Bus conf. command	0 = Ready	1 = Load

User interface

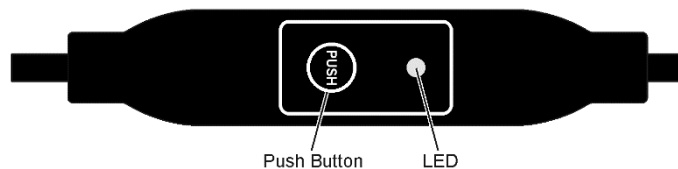

Pushbutton operation

Action	Pushbutton operation	Feedback message
Current Modbus address (starting from lowest address position)	Button pressure < 1s	1st digit: red 2nd digit: green 3rd digit: orange The LED blinks blue once after address indication and when bus termination is On Example: 124 = 4x red, 2x green, 1x orange
Switches bus termination On/Off	<p>Switch-on</p> <ol style="list-style-type: none"> 1. Press button 3x 2. Press button 1x briefly 3. Press button until the LED turns red 4. Release button <p>Switch-off</p> <ol style="list-style-type: none"> 1. Press button 3x 2. Press button until the LED turns red 3. Release button 	<p>Blinking or flickering of LED stops (termination mode)</p> <p>Blue LED blinks once</p> <p>RED LED is lit (confirmation)</p> <p>LED not lit</p> <p>Address is indicated</p> <p>LED blinks blue once following address indication</p> <p>Device enters normal mode</p> <p>Blinking or flickering of LED stops (termination mode)</p> <p>RED LED is lit (confirmation)</p> <p>Device enters normal mode</p>
Enter Modbus address using pushbutton	Press button > 1s and < 5s	See "Enter address using pushbutton", page 30

Action	Pushbutton operation	Feedback message
Enable pushbutton addressing (together with Climatix™ controllers)	1. Press button > 5s and < 10s 2. Release button	Red LED is lit and goes off after 5 s Orange LED is lit
Reset to factory settings	Press button > 10s	Orange LED blinking

LED Farben und Blinkmuster

Color	Blinking pattern	Description
Green	1s On / 5s Off	Normal mode without bus traffic
	Flickering	Normal mode with bus traffic
Orange / green	1s orange / 1s green	Device is in override control mode
Orange	1s On / 1s Off	Bus parameter not yet configured
	1s On / 5s Off	Device is in backup mode (replacement mode)
Red	Permanently lit	Mechanical error, device blocked, manual intervention or calibration
	1s On / 5s Off	Internal error
	0.1s On / 1s Off	Invalid configuration, e.g. Min = Max
Blue	Flickering once after address indication	Bus termination active
Dark	Dark	Fail safe function activated ¹⁾ or no power applied

¹⁾ Only for SAS61.33/MO, SAT61.51/MO

Reset actuator with pushbutton

1. Press button >10s → LED blinking **orange**
2. Release button *while* blinking → LED blinking for another 3s
3. Reset is interrupted if the pushbutton is pressed *during* the 3s
4. After 3s, → LED is lit **red** (reset) while the device restarts.

Enter address using pushbutton

The Modbus address can be set without extra tool by means of pushbutton addressing.

To display the current Modbus address, press the button <1s.

Enter new address (starting from the lowest address position)

Colors		
1st digit: red	2nd digit: green	3rd digit: orange
Example for address 124:		
LED		
Note	The address is entered and displayed beginning at the lowest digit (1st digit), see figure above. (Example: 124 starts with 4x red)	

Enter new address
(starting from lowest
address position)

1. **Enable addressing mode:** Press button > 1s until the LED is **red**, then release button (before LED goes off).
2. **Enter the numbers:** Push button n-times → LED blinks each time the button is pressed as a feedback.
Colors: 1st digit: **red** / 2nd digit: **green** / 3rd digit: **orange**
3. **Save digits:** Press button until LED is lit in the color of the next digit, then release the button,
4. **Save address:** Press button until LED is **red** (confirmation) →, then release button.
An address can be saved any time, i.e., after entering the 1st digit or after entering the 1st digit and 2nd digit.
5. The entered address is displayed again 1x for confirmation.

Note: Address entry is interrupted when the button is released before the LED is red, address entry is interrupted.

Example

Set address "124":

1. Enable addressing mode
2. Enter the 1st digit: Press button 4x → LED blinks **red** each time the button is pressed
3. Save 1st digit: Press button until LED is **green** – release button
4. Enter the 2nd digit: Press button 2x → LED blinks **green** each time the button is pressed
5. Save 2nd digit: Press button until LED is **orange** – release button
6. Enter the 3rd digit: Press button 1x → LED blinks **orange** each time the button is pressed
7. Save address: Press button until LED is **red** – release button
→ The address is saved and displayed 1x for confirmation

Set address "50":

1. Enable addressing mode
2. Skip over 1st digit: Press button until LED is **green** – release button
3. Enter the 2nd digit: Press button 5x → LED blinks **green** each time the button is pressed
4. Save address (skip 3rd digit): Press button until LED is **red** – release button
→ The address is saved and displayed 1x for confirmation

Set address "5":

1. Enable addressing mode
2. Enter the 1st digit: Press button 5x → LED blinks **red** each time the button is pressed
Save address: Press button until LED is **red** – release button
→ The address is saved and displayed 1x for confirmation

3.2.3 Maintenance

The actuators are maintenance-free.



Mounting:

- Do not touch the valve coupling if the components (valve/pipes) are hot
- If necessary, disconnect electrical connections from the terminals

The actuator must be correctly fitted to the valve before recommissioning.

3.2.4 Disposal

	⚠ WARNING
	Tensioned return spring Opening the actuator housing can release the tensioned return spring resulting in flying parts that may cause injury. <ul style="list-style-type: none">• Do not open the actuator body.

 	The device is considered electrical and electronic equipment for disposal in terms of the applicable European Directive and may not be disposed of as domestic garbage. <ul style="list-style-type: none">• Dispose of the device through channels provided for this purpose.• Comply with all local and currently applicable laws and regulations.
---	--

4 Functions and control

4.1 3-position control

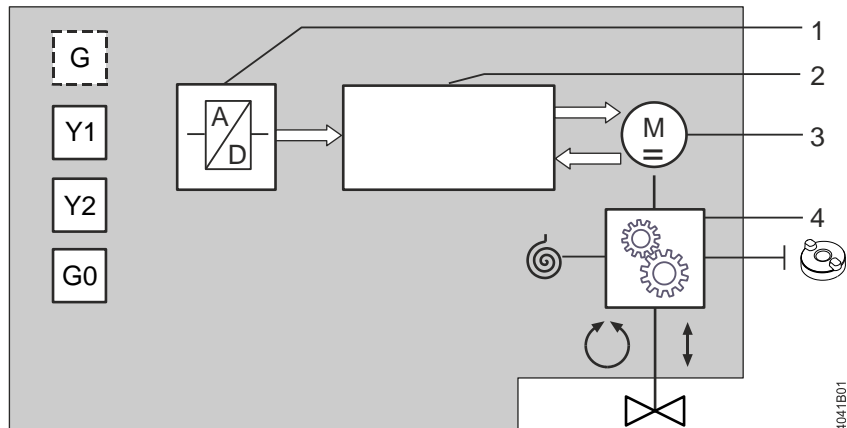

Example: brushless DC motor with fail safe function

A 3-position signal drives the actuator via connection terminals Y1 or Y2. The required position is transferred to the valve.

1	A/D conversion	
2	Control functions	Identification of seat
		Control of direction
		Motor control
		Manual adjustment
3	Brushless DC motor	
4	Gear train	
	Fail safe function	
	Manual adjuster	

Positioning signal	Stroke actuator	Control path valve A → AB	Bypass valve B → AB
Voltage at Y1	Actuator's stem extends	Opening	Closing
Voltage at Y2	Actuator's stem retracts	Closing	Opening
Voltage at Y1 and Y2	Actuator's stem maintains the position	Maintains the position	
No voltage at Y1 and Y2	Actuator's stem maintains the position	Maintains the position	
No voltage at Y1 and Y2; with fail safe function	Actuator's stem retracts	Closing	Opening

Note

Observe information given in chapter 4.2.1 Positioning signal and flow characteristic selection on page 38.

Internal control ensures very constant positioning times and determination of the actuator's position.

Positioning times stroke model

The specified positioning times refer to the respective nominal stroke. Since the end positions of rotary actuators are inside the actuator, the following remarks refer to stroke actuators.
 The resulting effective strokes vary, depending on the type of valve, resulting in shorter or longer actuator positioning times.

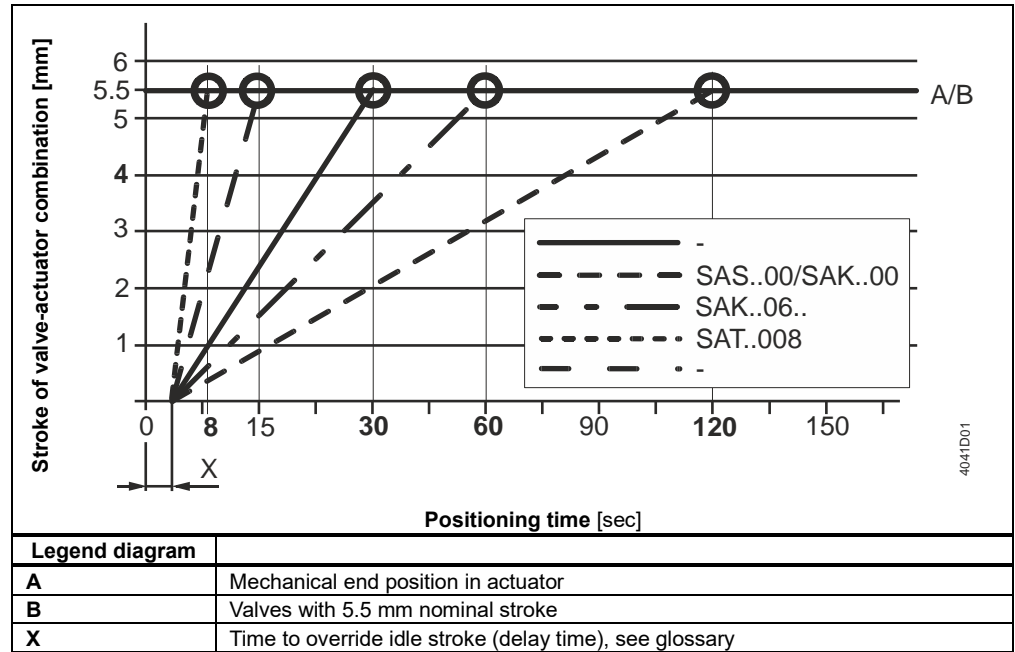

Notes

- Deviations occur
- after several positioning signals Y1 and Y2 in the same direction since the stroke movement starts with a delay of 50 ms (SAT31..., SAS31.53, SAS81.33) or 300 ms (SAS31../81..).
 - when positioning signals Y1 and Y2 are active for less than 50 ms or 300 ms since the stroke movement cannot be made in that case

Example of an actual position deviation on the **SAT31.008** at a 50 ms delay.

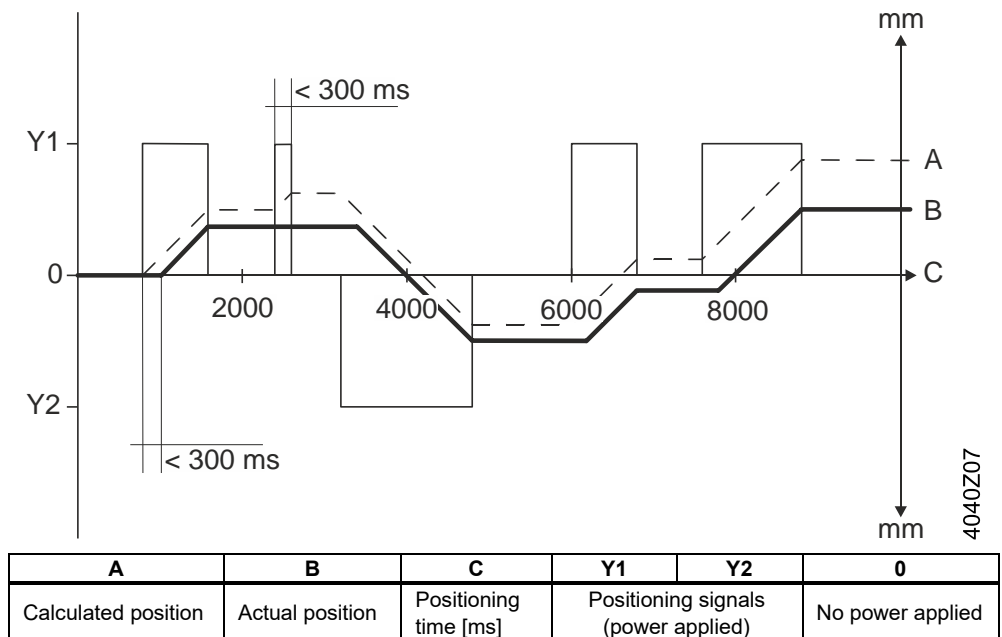

4.1.1 Combination with RVD.. controllers for direct domestic hot water distribution by heat exchanger

Notes

The design based slow reaction on control signals of SAS31.., SAS81.. and SAT31.. actuators doesn't allow the actuator to react on very short control pulses. Only control pulses of a sufficient length (ca. >50 ms for SAS31.53, SAS81.33 and SAT31..; ca. >300 ms for the remaining SAS31.. and SAS81.. types), allow for a sufficient reaction.

Especially the direct domestic hot water control does not allow such long control pulses.

The specific optimized control loops – e.g. equipped with an SIGMAGYR RVD.. controller and SQS359.05 actuator¹⁾ – work with pulses down to 40 ms.

Some of the actuators mentioned above are not able to work with these short pulses.

The following table shows which actuators can be used for those special applications.

Controller	Plant type	Preferred actuator	Valve line	DN	k _{vs}
RVD130 ¹⁾	4 und 5	SQS35.53 ¹⁾	VVG44..	DN 15...40	0.25...25
RVD1357109 ¹⁾		SAS31.53	VVG549..	DN 15...25	0.25...6,3
RVD135/309 ¹⁾		SQS259.53 ¹⁾			
RVD140		SAT31.008			
RVD144/109		SQS259.43 ¹⁾	VVG41..	DN 15...50	0.63...40
RVD145/109		SAT31.51			
RVD139 ¹⁾		SKD32.21..	VVF53..		0.16...40
RVD230 ¹⁾	.. - 4	SQS35.53 ¹⁾	VVG44..	DN 15...40	0.25...25
RVD235/109 ¹⁾		SAS31.53	VVG549..	DN 15...25	0.25...6,3
RVD250		SQS259.53 ¹⁾			
RVD255/109		SAT31.008			
RVD240 ¹⁾		SQS259.43 ¹⁾	VVG41..	DN 15...50	0.63...40
RVD245/109 ¹⁾		SAT31.51			
RVD260		SKD32.21..	VVF53..		0.16...40
RVD265/109					

¹⁾ No longer available.

4.2 Modulating control

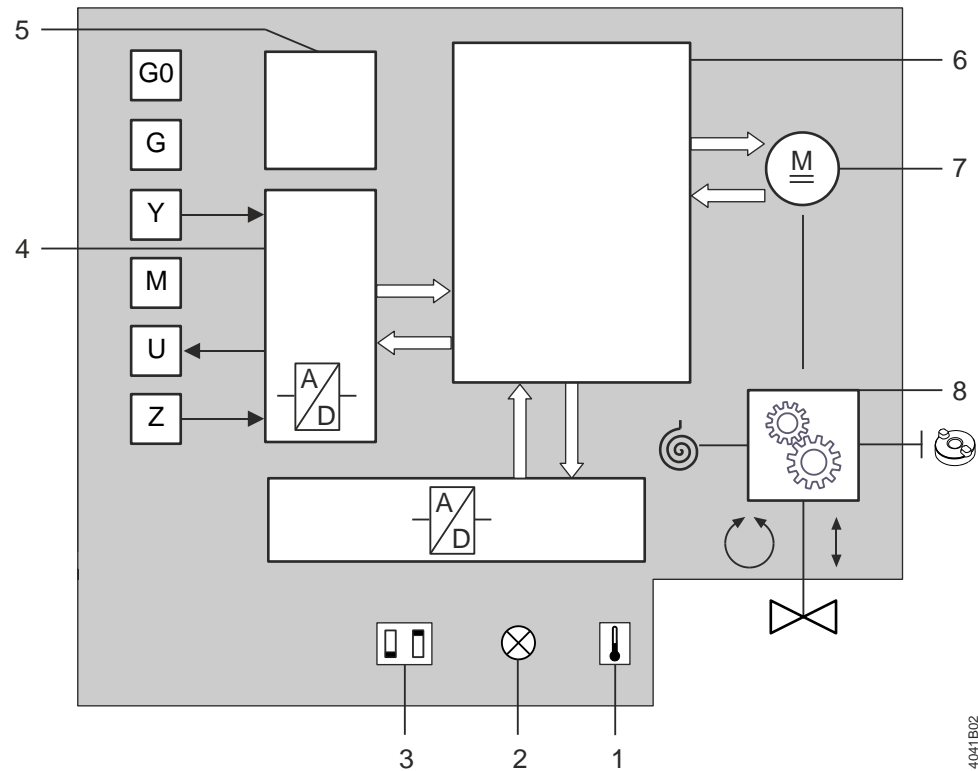

The positioning signal range (DC 0...10 V / DC 4...20 mA / 0...1000 Ω) corresponds in a linear manner to the positioning range (fully closed...fully open, or 0...100 % stroke).

The actuator is controlled via terminal Y or forced control Z (page 42). The desired stroke is transferred to the valve stem.

1	Calibration slot	
2	LED (2 colors)	
3	DIL switches	Changeover of characteristic
		Positioning signal
4	A/D conversion	
5	Power supply	
6	Control functions	Identification of seat
		Position control
		Motor control
		Detection of foreign bodies
		Calibration
		Forced control
		Characteristics function
Manual adjustment		
7	Brushless DC motor	
8	Gear train	
	Fail safe function	
	Manual adjuster	

Positioning signal	Stroke actuator	Control path valve A→AB	Bypass valve B → AB
Signal Y, Z increasing	Actuator's stem extends	Opening	Closing
Signal Y, Z decreasing	Actuator's stem retracts	Closing	Opening
Signal Y, Z constant	Actuator's stem maintains the position	Maintains the position	
No voltage at Y1 and Y2; with fail safe function	Actuator's stem retracts	Closing	Opening





Note

Observe the information given in chapter 4.2.1 Positioning signal and flow characteristic selection on page 38.

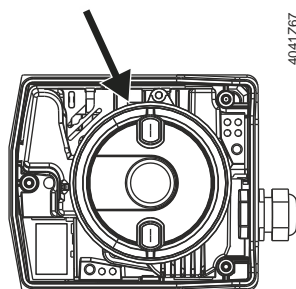
4.2.1 Positioning signal and flow characteristic selection

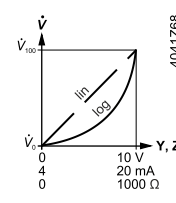
DIL switches

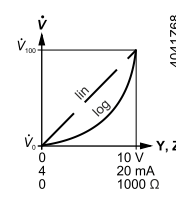

	Positioning signal "Y"	Position feedback "U"	Flow characteristic
ON	 DC 4...20 mA	DC 0...10 V	
OFF	 DC 0...10 V	DC 0...10 V	
ON	 DC 0...10 V	DC 0...10 V	
OFF	 DC 0...10 V	DC 0...10 V	

1) Factory setting: All DIL switches set to OFF

Note

Factory setting SAS..:

- Characteristic curve : log = Equal percentage (switch at "OFF")
- Positioning signal: DC 0...10 V (switch at "OFF")

Factory setting SAT..:

- Characteristic curve: lin = linear (switch at "ON")
- Positioning signal: DC 0...10 V (switch at "OFF")

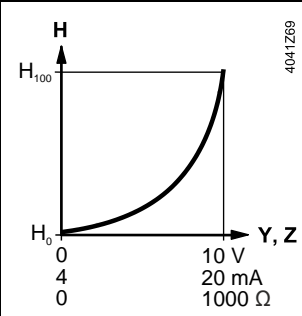
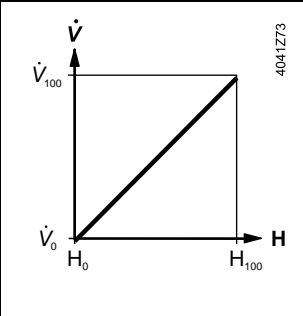
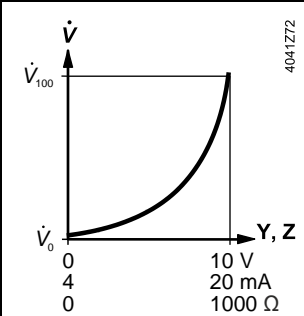
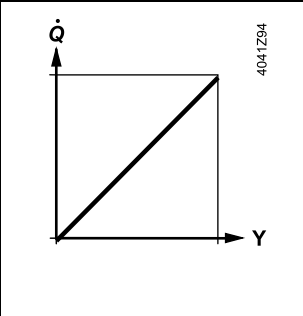
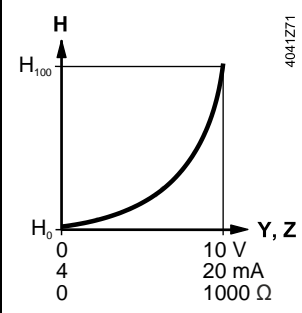
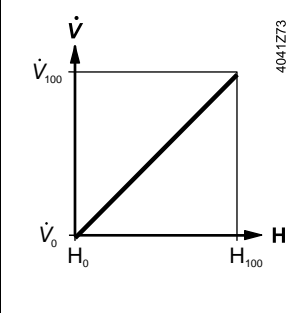
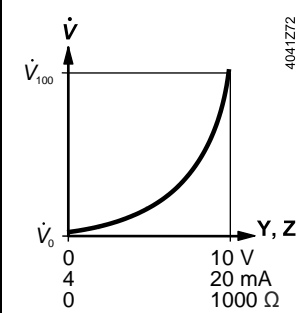
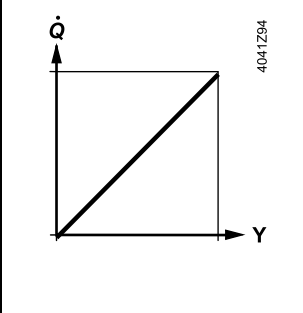

Flow characteristic

Actuator SAT..	Valve VVG55.. / VVG549..	Valve & actuator combined	Valve & actuator & heat exchanger combined
			
Actuator SAS..	Valve VVG44.. / VXG44..	Valve & actuator combined	Valve & actuator & heat exchanger combined
			

Y, Z Positioning signal
H Stroke
V $\dot{}$ Volumetric flow
Q $\dot{}$ Heat transfer capacity

4.2.2 Position feedback U

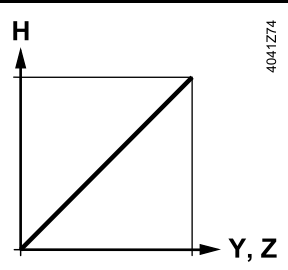
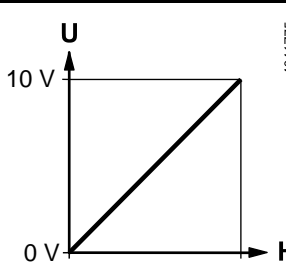
The position feedback U (DC 0...10 V) is always proportional to stroke H of the actuator's stem.

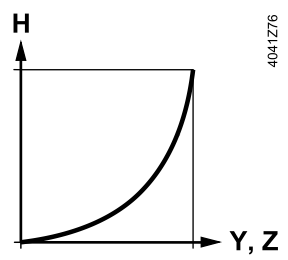
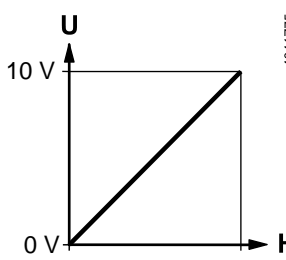
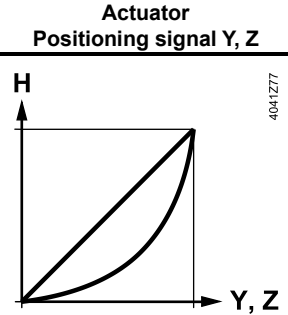
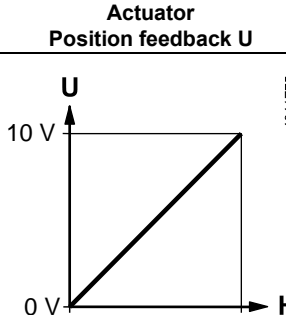
	Actuator Positioning signal Y, Z	Actuator Position feedback U						
 lin = linear	 4041Z74	 4041Z75						
 log = equal-percentage	 4041Z76	 4041Z75						
<table border="1"> <tr> <td>Y, Z</td> <td>Positioning signal</td> </tr> <tr> <td>H</td> <td>Stroke</td> </tr> <tr> <td>U</td> <td>Position feedback</td> </tr> </table>	Y, Z	Positioning signal	H	Stroke	U	Position feedback	 4041Z77	 4041Z75
Y, Z	Positioning signal							
H	Stroke							
U	Position feedback							

4.2.3 Calibration

To match the actuator to production-related mechanical tolerances of the individual valves and to guarantee accurate positioning and position feedback, a calibration should be performed when the plant is commissioned (page 26). During commissioning, the actuator detects the valve's end positions and files the exact stroke in its internal memory.

Calibration takes place in the following phases:

- Actuator drives to the upper end position (1), valve closes. Detection of upper end position.
- Actuator drives to the lower end position (2), valve opens. Detection of lower end position.
- The detected values are stored (3). Then the actuator follows the positioning signal.

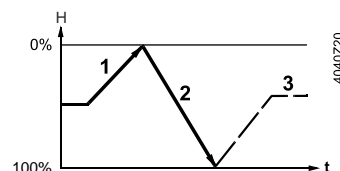

Note

Observe status indication (LED) during and after calibration (page 50).

4.2.4 Signal priorities

The actuators are controlled via different interlinked positioning signal paths (positioning signal "Y", forced control input "Z", manual adjuster). The signal paths are assigned the following priorities (1 = highest priority, 4 = lowest priority):

Actuator without fail safe function



Priority	Description	
1	The manual adjuster always has priority 1, thus overriding all signals active at "Z" or "Y", independent of whether or not power is applied.	
2	Only SA..61..: As soon as a valid positioning signal is active at input "Z", the position is determined via positioning signal "Z" (forced control). Prerequisite: The manual adjuster is not used.	Z
3	The position is determined via positioning signal "Y" at Y, Y1 or Y2. The manual adjuster is not used and on "Z" there is no active signal.	Y

Examples

Manual adjuster	Forced control (Z)	Positioning signal (Y)	Stroke actuator	Rotary actuator
Automatic mode	Not connected	5 V	Actuator's stem travels to position (50%)	Actuator's spindle travels to position (50%)
Automatic mode	G	3 V	Actuator's stem extends	Actuator's spindle turns in clockwise direction
Automatic mode	G0	3 V	Actuator's stem retracts	Actuator's spindle turns in counterclockwise direction
Operated (30%) and engaged	G	8 V	Actuator's stem extends manual (to 30%)	Actuator's spindle turns manually in counterclockwise direction (to 30%)

Bold printing = positioning signal currently active

Actuator with fail safe function

Priority	Description	
1	The fail safe function responds in the event of a power failure.	
2	The position is solely determined via positioning signal "Z" (forced control), provided power is applied.	Z
3	The position is determined by positioning signal Y, provided power is applied and positioning signal "Z" is not used.	Y
4	Upon actuation and slightly turning in counterclockwise direction, the manual adjuster remains engaged. Power applied: After 5 seconds, the manual adjuster disengages itself and positioning signal "Y" or "Z" determines the position. No power applied: The actuator maintains the position defined by the manual adjuster until power returns. Upon restoration of power, an automatic ClosedPosition-Synchronisation will be performed.	

Examples

Operating voltage (G/G0)	Manual adjuster	Forced control (Z)	Positioning signal (Y)	Stroke actuator
Applied	Automatic mode	Not connected	5 V	Actuator's stem travels to position (50%)
Applied	Automatic mode	G	3 V	Actuator's stem extends
Applied	Automatic mode	G0	3 V	Actuator's stem retracts
Interrupted (fail safe function)	Automatic mode	G	6 V	Actuator's stem retracts (until end position is reached)
Interrupted (fail safe function)	Operated (30%) and engaged	G	8 V	Actuator's stem retracts (until end position is reached), then: Actuator's stem extends manually (to 30%)

Bold printing = positioning signal currently active

4.2.5 Detection of valve seat

SAS..

The actuators feature force-dependent valve seat detection. After calibration, the exact valve stroke is filed in the actuator's memory. If no force is built up in the calculated end position (e.g. in the event of temperature effects for instance), the actuator continues to operate at a reduced positioning speed until the nominal positioning force is restored. This ensures that the valve always fully closes. After a power failure, valve seat identification is not active – the actuators without fail safe function define their stroke position on power resoration to be at 50%. From now on, the actuator follows the positioning signal. When the valve plug reaches its seat for the first time, the actuator readjusts its stroke model.

Example

The supposed position is 50%, $Y = 2\text{ V}$, the actuator travels 30% of the stored valve stroke in the direction of "Actuator's stem retracted". If the actuator reaches the seat within this 30% travel, it interprets the position as "Valve fully closed" and shifts the position of the valve's stroke accordingly without changing the extent of travel. From now on, the actuator follows the changed valve stroke position. This means: New position 0%, $Y = 2\text{ V}$, actuator travels 20% of the stored valve stroke in the direction "Actuator's stem extended".

4.2.6 Detection of foreign bodies

The actuator detects when the valve is clogged and adjusts its operational behavior accordingly to prevent damage to itself or the valve. If the actuator hits an obstacle within the calibrated stroke and is not able to overcome it with its nominal positioning force, it stores the position at which the obstacle was hit. Depending on the direction of travel, as ...

"Upper limit of valve clogging", if the clogging was detected when traveling in the direction of "Actuator's stem extending".

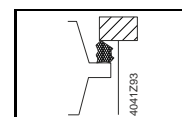

Now, the status LED blinks red and the actuator only follows the positioning signal between the positions "Actuator's stem retracted" and "Lower limit of valve clogging".

After detection of clogging, 3 attempts are made to overcome clogging by traveling about 15% in the opposite direction and then trying again to overcome the position of clogging. If the attempts made are unsuccessful, the actuator continues to follow the positioning signal within the restricted range only and the LED continues to blink red (see "Status indication " page 50).

4.2.7 Forced control Z

Forced control uses the following operating modes:

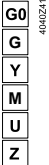
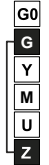
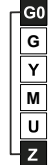
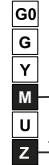
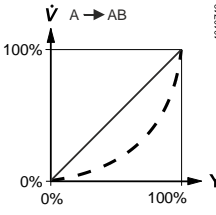
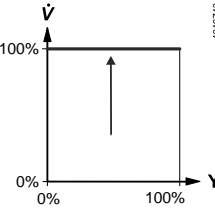
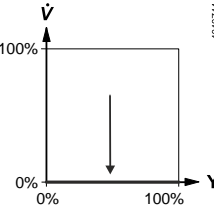
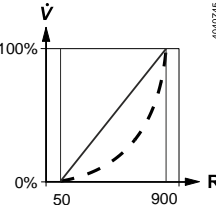
		Z mode			
		No function	Fully open	Fully closed	Overriding positioning signal "Y" by 0...1000 Ω
Connections					
	Transmission				
		Equal-percentage or linear characteristic			Equal-percentage or linear characteristic
		Contact "Z" not connected, valve follows positioning signal "Y"	Contact "Z" is connected directly to "G", positioning signal "Y" has no impact	Contact "Z" is connected directly to "G0", positioning signal "Y" has no impact	Contact "Z" is connected to "M" via resistor "R", starting point at 50 Ω, end point at 900 Ω, positioning signal "Y" has no impact

4.3 Communicating actuators Modbus RTU

4.3.1 Detection of valve seat

SAS..

The actuators feature force-dependent valve seat detection. After calibration, the exact valve stroke is filed in the actuator's memory.

If no force is built up in the calculated end position (e.g. in the event of temperature effects for instance), the actuator continues to operate at a reduced positioning speed until the nominal positioning force is restored. This ensures that the valve always fully closes.

After a power failure, valve seat identification is not active – the actuators without fail safe function define their stroke position upon return of power at 50%. And sets its internal setpoint in register 1 to 0%. The actuator closes at this setting. There is a short-term deviation between the setpoint and the internal stroke position that results in an error message in register 769 "Mechanical error, device blocked". The error message disappears after just a few seconds.

When the valve plug reaches its seat for the first time, the actuator readjusts its stroke mode.

Example

Setpoint prior to power outage 35%, no manual adjustment during the power outage. Internal stroke position value after return of power 50%. Internal setpoint after return of power 0%. There is an error message for a brief time prior to the actuator moving since the setpoint of 0% is not equal to the position feedback of

50%. The error message disappears as soon as the actuator moves. The actuator moves 35% in the direction of "Retract actuator stem" and reaches the valve seat. The internal stroke position is set to 0%. The actuator now follows the changed valve stroke position effective immediately.

4.3.2 Detection of foreign bodies

The actuator detects when the valve is clogged and adjusts its operational behavior accordingly to prevent damage to itself or the valve.

If the actuator hits an obstacle within the calibrated stroke and is not able to overcome it with its nominal positioning force, it stores the position at which the obstacle was hit

As "Upper limit of valve clogging", if the clogging was detected when traveling in the direction of "Actuator's stem extending".

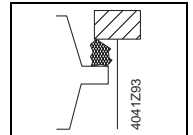

Now, the status LED blinks red and the actuator only follows the positioning signal between the positions "Actuator's stem retracted" and "High limit of valve clogging". After detection of clogging, 3 attempts are made to overcome clogging by traveling about 15% in the opposite direction and then trying again to overcome the position of clogging. If the attempts made are unsuccessful, the actuator continues to follow the positioning signal within the restricted range only and the LED continues to blink red (see "Indicators", page 50).

As long as the external setpoint is greater than the position of the high limit valve clogging, the deviation between the setpoint and position feedback in register 769 is displayed with the warning "Mechanical error, device blocked, manual intervention or calibration." The LED on the cable adapter is red. The warning is reset if the external setpoint drops below the high limit valve clogging, since the setpoint and stroke position are once again the same. The LED on the cable adapter switches to green blinking (=communication).

4.3.3 Calibration

To match the actuator to production-related mechanical tolerances of the individual valves and to guarantee accurate positioning and position feedback, a calibration should be performed when the plant is commissioned (page 26). During commissioning, the actuator detects the valve's end positions and files the exact stroke in its internal memory.

Calibration takes place in the following phases:

- Actuator drives to the upper end position (1), valve closes. Detection of upper end position.
- Actuator drives to the lower end position (2), valve opens. Detection of lower end position.
- The detected values are stored (3). Then the actuator follows the positioning signal.

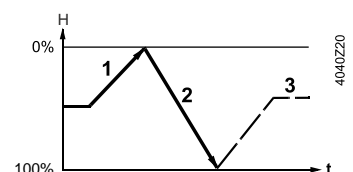

The internal position feedback is set to 0% during calibration. For a setpoint > 0%, the actuator detects calibration based on the deviation between setpoint and stroke position and reports this in Register 769 with the warning "Mechanical error, device blocked, manual intervention or calibration". The LED on the actuator cover blinks green, the LED on the cable adapter is red.

After calibration is completed, the actuator follows the external setpoint, the warning is reset, the LED on the cover changes to continuous green and the cable adapter blinks green (communication active).

Note

Observe status indication (LED) during and after calibration (page 50).

4.3.4 Manual adjustment

The actuator's internal stroke position measurement is inactive during manual adjustment.

The position feedback changes to 0% once the manual adjuster is pressed and remains on the value during manual adjustment. The actuator detects manual action based on the deviation between the setpoint and the stroke position and reports in register 769 with the warning "Mechanical error, device blocked, manual intervention or calibration". The LED on the actuator cover blinks green, the LED on the cable adapter is red.

Upon return to automatic mode, the actuator synchronizes to stroke position 0%. After the synchronization, the actuator follows the pending setpoint, the LED on the cover changes to continuous green and, on the cable adapter, blinking green (communication active). The warning in register 769 is reset.

4.3.5 Parameters and function description

Reg.	Name	R/W	Unit	Scaling	Range / listing
Process values					
1	Setpoint	RW	%	0.01	0..100
2	Forced control	RW	--	--	0 = Off / 1 = Open / 2 = Close 3 = Stop / 4 = Min / 5 = Max
3	Actual value position	R	%	0.01	0..100
256	Command	RW	--		0 = Ready / 1 = Adaption / 2 = Self test 3 = Reinitialize / 4 = Remote reset

Parameters					
259	Op mode	RW	--	--	1 = POS
260	MinPosition	RW	%	0.01	0..100
261	MaxPosition	RW	%	0.01	0..100
262	Actuator runtime	R	s	1	30
263	Positioning signal characteristic between Y and U	RW	--	--	0 = Linear (e.g. SAX61../MO + V_G41) 1 = Logarithmic (e.g. SAS61../MO + V_G44)
264	Tolerance blockade monitoring	RW	%	0.01	0..10
513	Backup mode	RW	--	--	0 = Move to backup position 1 = Maintain last position / 2 = Disable
514	Backup position	RW	%	0.01	0..100
515	Backup timeout	RW	s	1	0..65535
516	Startup setpoint	RW	%	0.01	0..100
764	Modbus address	RW	--	--	1..247 / 255 = "unassigned"
765	Baud rate	RW	--	--	0 = auto / 1 = 9600 / 2 = 19200 3 = 38400 4 = 57600 / 5 = 76800 / 6 = 115200
766	Transmission format	RW	--	--	0 = 1-8-E-1 / 1 = 1-8-O-1 / 2 = 1-8-N-1 / 3 = 1-8-N-2
767	Bus termination	RW	--	--	0 = Off / 1 = On
768	Bus config. command	RW	--	--	0 = Ready / 1 = Load / 2 = Reject
769	Status	R	--	--	See Section, Register 769 "Status"

Reg.	Name	R/W	Value	Example																				
Device information																								
1281	Factory Index	R	Two bytes, each coding an ASCII char.	00 5A → 00 "Z" Device is of Series "Z"																				
1282	Factory Date HWord	R	Two bytes, the lower coding the Year (hex)	Read 1282 → 000F Read 1283 → 0418																				
1283	Factory Date LWord	R	High byte: coding the month (hex) Low byte: coding the day (hex)	<table border="1"> <thead> <tr> <th></th> <th colspan="2">HWord</th> <th colspan="2">LWord</th> </tr> <tr> <th></th> <th>--</th> <th>YY</th> <th>MM</th> <th>DD</th> </tr> </thead> <tbody> <tr> <td>Hex</td> <td>00</td> <td>0F</td> <td>04</td> <td>18</td> </tr> <tr> <td>Dec</td> <td>00</td> <td>15</td> <td>04</td> <td>24</td> </tr> </tbody> </table> <p>→ Device was manufactured 24 April, 2015</p>		HWord		LWord			--	YY	MM	DD	Hex	00	0F	04	18	Dec	00	15	04	24
	HWord		LWord																					
	--	YY	MM	DD																				
Hex	00	0F	04	18																				
Dec	00	15	04	24																				
1284	Factory SeqNo HWord	R	Hword + LWord = HEX-representation of Sequence number:	Read 1284 → 000A																				
1285	Factory SeqNo LWord	R		Read 1285 → A206 AA206(hex) → 696838 (dec) → Device has sequence number 696838																				
1409	ASN [Char_16..15]	R	Each register: Two bytes, each coding an ASCII char. ASN is coded beginning with reg. 1409	Example: 0x47 44 = GD 0x42 31 = B1 0x38 31 = 81 0x2E 31 = .1 0x45 2F = E/ 0x4D 4F = MO → ASN is GDB181.1E/MO																				
1410	ASN [Char_14..13]	R																						
1411	ASN [Char_12..11]	R																						
1412	ASN [Char_10..9]	R																						
1413	ASN [Char_8..7]	R																						
1414	ASN [Char_6..5]	R																						
1415	ASN [Char_4..3]	R																						
1416	ASN [Char_2..1]	R																						
				Reserve																				

Register 769 "Status"

Status			
Bit 00	1 = Reserved	Bit 06	1 = Adaption conducted
Bit 01	1 = Backup mode active	Bit 07	1 = Adaption running
Bit 02	1 = Reserved	Bit 08	1 = Adaption error
Bit 03	1 = Reserved	Bit 09	1 = Self test failed
Bit 04	1 = Mechanical error, device blocked, manual intervention or calibration	Bit 10	1 = Self test successful
Bit 05	1 = Life cycle reached	Bit 11	1 = Invalid configuration

Supported function codes

Function codes	
03 (0x03)	Read Holding Registers
04 (0x04)	Read Input Registers
06 (0x06)	Write Single Register
16 (0x10)	Write Multiple Registers (Limitation: Max. 120 registers on one write access)

Function	Reg.	Description
Override control	2	The actuator can be operated in override control for commissioning / maintenance purposes or system-wide functions (e.g. night-cooling). <ul style="list-style-type: none"> • Manual override: When the gear disengagement is used to freely adjust the damper position, a mechanical jam will be detected if a mismatch between setpoint and actual position persists for more than 10s. • Remote override: The actuator enters this state when an override command is sent over the bus. • Available commands: <ul style="list-style-type: none"> ○ Open / Close (depends on opening direction)

		<ul style="list-style-type: none"> ○ Min / Max (depends on Min/Max settings) ○ Stop
Backup mode	513, 514, 515	<ul style="list-style-type: none"> ● In case the communication to the controller is lost, the device can be configured to go into a defined state. ● Default setting mode is "keep last setpoint", i.e. in case of communication loss, the device controls to the last received setpoint. ● If the backup mode is enabled, it can be configured as follows: <ul style="list-style-type: none"> ○ go to a predefined backup position ○ keep current position
Restarting the device	256	Restarting is possible by: <ul style="list-style-type: none"> ● Power-reset (turning operating voltage off and on) or ● by "ReInitDevice" command. → Device re-initializes and sets all process values to defaults.
Reset		The actuator supports the following re-initialization / reset behaviour: <ul style="list-style-type: none"> ● Local reset by push-button ● Remote reset: Using "RemoteFactoryReset" command. Effect of reset: Process values: set to ex-works default values. <ul style="list-style-type: none"> ● Parameters: <ul style="list-style-type: none"> ○ Application and actuator parameters are set to factory defaults, ○ Network parameters are reset only in case of local reset, not by remote reset (otherwise loss of communication). ● Not reset are: Counters, status flags, device info, and factory data.
Self test	256	When triggered, the self test drives the actuator to the detected limits and sets the flags in register 769 according to the result (bit 09 = 1 → "failed" or bit 10 = 1 → "passed"). The self test is not passed when the limits were not reached from the lower end (results in jam). If the Min/Max limits can be exceeded, the self test is not evaluated as failed.

Communication properties

Communication		
Communications protocol	Modbus RTU	RS-485, not galvanically separated
	Number of nodes	Max. 32
	Address range	1...247 / 255 Factory settings: 255
	Transmission formats	1-8-E-1 / 1-8-O-1 / 1-8-N-1 / 1-8-N-2 Factory settings: 1-8-E-1
	Baud rates (kBaud)	Auto / 9,6 / 19,2 / 38,4 / 57,6 / 76,8 / 115,2 Factory settings: Auto
	Bus termination	120 Ω electronically switchable Factory settings: Off

4.4 Technical and mechanical design

4.4.1 Transmission of power

Function principle

Incoming positioning signals are translated to positioning commands for the motor.

A gear train transmits the motor's positioning steps to the output stage. Here, the translation from rotary to stroke movement takes place. Attached to the gear train are the electrical and mechanical accessory items and the manual adjuster. With the stroke actuators with fail safe function, the gear train also accommodates the return spring.

4.4.2 Kopplung

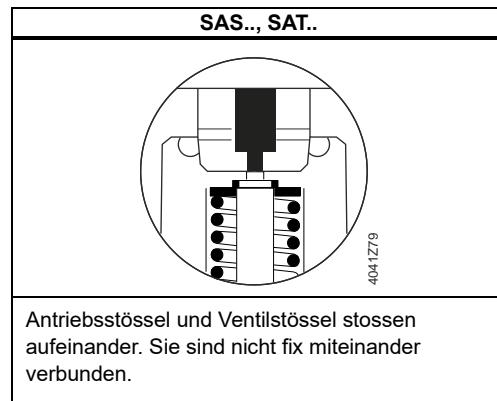

4.4.3 Fail safe function

The fail safe function works mechanically with a return spring and ensures the protection of the plant. It guarantees the safe operation in uncontrolled operating states.

In the event of a power failure, the actuator will return to its 0 % stroke position with the help of the return spring, closing the valve. The Y positioning signal is not valued.

Fail safe function	Actuator	Valve		Spring return time	At positioning time
Active	Actuator's stem retracts	Spring in valve closes	Valve closes	<8 s ¹⁾ <14 s ¹⁾ <28 s ¹⁾	15 s 30 s 120 s

¹⁾ Spring return time increased slightly at low temperatures

4.4.4 Manual adjuster

Automatic

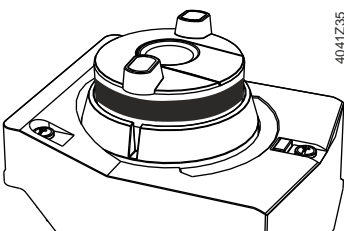
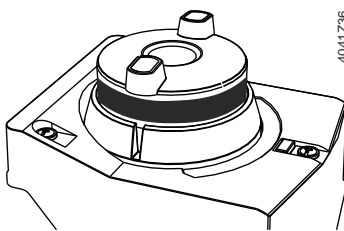
Without fail safe function	With fail safe function (SA..33..)
 4041Z35	 4041Z36

When the motor drives the manual adjuster turns. Thus in automatic mode, the manual adjuster is used for indication of travel. If the manual adjuster is held firm in this mode, there is no transmission of power to the gear train.

Manual operation

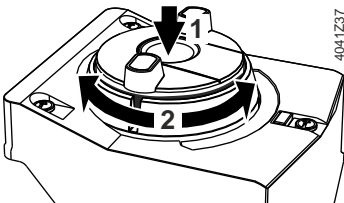
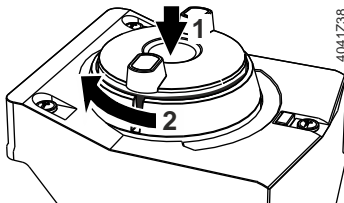
 4041Z37	 4041Z38
---	---

When pushing the manual adjuster down (1), it engages and the actuator can be manually operated.

Stroke actuator: When turning the manual adjuster in clockwise / counterclockwise direction (2), the actuator's stem extends / retracts.

Rotary actuator: The actuator spindle turns in the same direction

When turning the manual adjuster in clockwise direction (2), the actuator's stem extends.

CAUTION: Turning the manual adjuster in counterclockwise direction is not possible.

An overload protection prevents damage to the manual adjuster.

Fixing the position

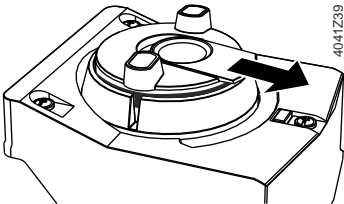
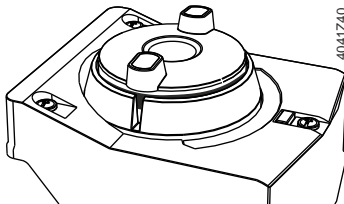
 4041Z39	 4041Z40
---	---

Upon actuation and locking the slide switch, the manual adjuster remains engaged.

When in this mode, do not turn the manual adjuster (manual adjuster locked).

After pushing and slightly turning the manual adjuster in counterclockwise direction, it remains engaged, provided no power is applied.

If power is applied, refer to "Disengaging the fixing".

Disengaging the fixing

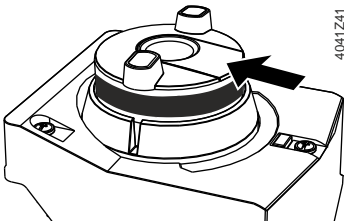
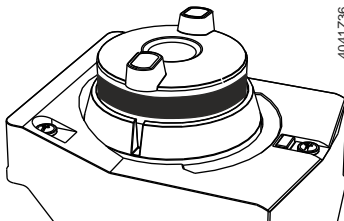
 4041Z41	 4041Z36
---	---

When resetting the slide switch, the manual adjuster returns to automatic mode.

Coupling disengages **automatically**...

- after 5 seconds if power is applied,
- when power returns; a restart is made (actuator's stem retracts), then, the actuator follows the active positioning signal.

Coupling is disengaged **manually** by slightly turning the manual adjuster in clockwise direction.

4.4.5 Indicators

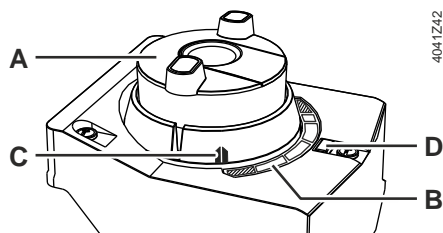

A	Indication of travel	
B	Scale	Position indication
C	Indicator	
D	LED Status indication	

Operational status indication

In Automatic mode, the manual adjuster serves for the indication of travel. See "Automatic" (page 49).

Position indication

When turning the manual adjuster, the indicator also moves. The scale indicates the stroke. When reaching the stops, the valve is either fully open or fully closed.

Status indication (LED), only with modulating control (only SA..61..)

Housing cover fitted	Housing cover removed
When the housing cover is fitted, the LED can be viewed through a light conductor.	When the housing cover is removed, the LED can be viewed through a hole.

The status indication informs about the operational state of the actuator.

LED	Indication	Operating state	Remarks, troubleshooting
Green	On	Automatic mode	Normal operation
	Blinking	Calibration	Wait until calibration is finished (then green or red light)
		In manual mode	Manual adjuster in MAN position
Red	On	Calibration error	Start calibration again
		Undervoltage (AC 13 V)	Check operating voltage
	Blinking	Clogged valve, detection of foreign bodies	Check valve / actuator
Dark	Dark	No power or electronics faulty	Check operating voltage

4.4.6 Electrical accessories

Auxiliary switch ASC10.51

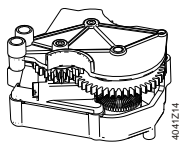

AC 24 V...230 V / 6 (3) A

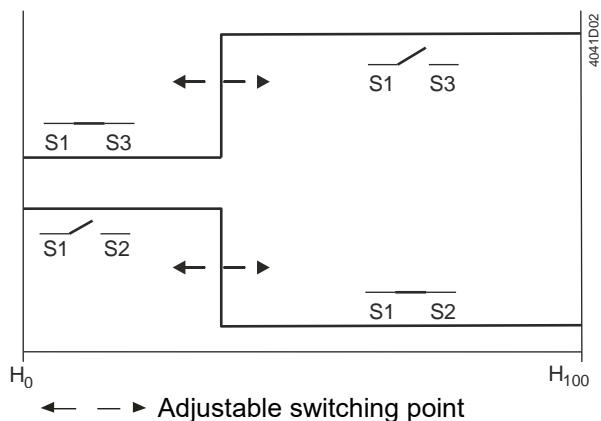
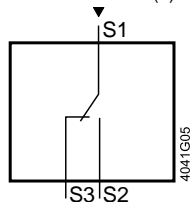

Switching point for S1–S2 and S1–S3 cannot be set separately. If S1–S2 is open then S1–S3 is closed.

Application example:

When using an auxiliary switch, position feedback can trigger an automatic stop of the circulating pump in the end position "Fully closed".

4.4.7 Mechanical accessories

Weather shield ASK39.2

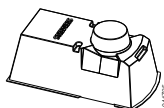

To protect the actuator from weather effects when used outdoors, the weather shield ASK39.2 must always be fitted. The housing protection IP54 remains unchanged. See also page 13.

Adapter set ASK30

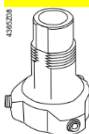

Adapter set for ex-Landis & Gyr valves with 4 mm or 5.5 mm strokes: X3i., VVG45., VXG45., VXG46., VVI51... See page 22

5 Technical data

		SAS..	SAT..
Power supply	Operating voltage	SA..31..	AC 230 V ± 15 %
		SA..61..	AC 24 V ± 20 % / DC 24 V + 20 % / -15% or AC 24 V class 2 (US)
		SA..81..	AC/DC 24 V ± 20 % or AC 24 V class 2 (US)
	Frequency	45...65 Hz	
	External supply line protection (EU)	6 A...10 A slow or Circuit breaker max. 13 A Characteristic B, C, D according to EN 60898 Power source with current limitation of max. 10 A	
	Power consumption at 50 Hz	Stem retracts / extends	Stem retracts / extends
	SAS31.00 SAT31.008	2.8 / 2.4 VA ¹⁾	5.0 / 2.5 VA ¹⁾
	SAS31.03 SAT31.51	3.5 / 2.9 VA ¹⁾	5.5 / 3.2 VA ¹⁾
	SAS31.50 SAT61.008	3.5 / 2.9 VA ¹⁾	7.1 / 4.6 VA ¹⁾
	SAS31.53 SAT61.008/MO	5.5 / 3.8 VA ¹⁾	6.4 / 4.8 VA ¹⁾
	SAS61.03 SAT61.51	5.3 / 4.5 VA ¹⁾	6.4 / 4.8 VA ¹⁾
	SAS61.03U SAT61.51/MO	5.3 / 4.5 VA ¹⁾	6.4 / 4.8 VA ¹⁾
	SAS61.03/MO	6.0 / 5.2 VA ¹⁾	
	SAS61.33	5.9 / 4.8 VA ¹⁾	
	SAS61.33U	5.9 / 4.8 VA ¹⁾	
SAS61.33/MO	6,6 / 5,5 VA ¹⁾		
SAS61.53	5.8 / 5.0 VA ¹⁾		
SAS81.00	2.2 / 2.0 VA ¹⁾		
SAS81.03	2.5 / 2.1 VA ¹⁾		
SAS81.03U	2.5 / 2.1 VA ¹⁾		
SAS81.33	3.4 / 2.4 VA ¹⁾		
SAS81.33U	3.4 / 2.4 VA ¹⁾		
Function data	Positioning times with the specified nominal stroke		
	SAS..0 SAT..008	120 s	8 s
	SAS..3/.33U SAT..51	30 s	15 s
	Positioning force	400 N	300 N
	Nominal stroke	5.5 mm	5.5 mm
	Permissible medium temperature (valve fitted)	1...130 °C	1...130 °C
	briefly	150 °C (up to 150 °C max. 6 of 24 hours)	
Signal inputs	Y positioning signal		
	SAS31.. SAT31.008		3-position
	SAS81.. SAT31.51		
	SAS61.. SAT61.008		DC 0...10 V / DC 4...20 mA / 0...1000 Ω
		SAT61.51	
	SA..61.. (DC 0...10 V) Current draw		≤ 0.1 mA
	Input impedance	≥ 100 kΩ	
SA..61.. (DC 4...20 mA) Current draw		DC 4...20 mA ± 1 %	
	Input impedance	≤ 500 Ω	

Communication SA..61../MO	Communications protocol			
		Modbus RTU	RS-485, not galvanically separated	
		Number of nodes	Max. 32	
		Address range	1...247 / 255 Factory settings: 255	
		Transmission formats	1-8-E-1 / 1-8-O-1 / 1-8-N-1 / 1-8-N-2 Factory settings: 1-8-E-1	
		Baud rates (kBaud)	Auto / 9.6 / 19.2 / 38.4 / 57.6 / 76.8 / 115.2 Factory settings: Auto	
		Bus termination	120 Ω electronically switchable Factory settings: Off	
Parallel operation	SA..61..	≤ 10 (depending on controller output)		
Forced control	Positioning signal Z	SA..61..	R = 0...1000 Ω, G, G0	
		R = 0...1000 Ω	Stroke proportional to R	
		Z connected to G	Max. stroke 100 %	Max. stroke 100 %
		Z connected to G0	Min. stroke 0 %	Min. stroke 0 %
		Voltage	Max. AC 24 V ± 20 % / Max. DC 24 V + 20 % / -15%	
		Current draw	≤ 0.1 mA	
Position feedback	U	Voltage range SA..61..	DC 0...10 V	
		Load impedance	> 10 kΩ res.	
		Load	Max. 1 mA	
Connecting cable	Wire cross-sectional areas		0.75...1.5 mm ² , AWG 20...16 ²⁾	
	Cable entries	SA..	EU: 1 entry ∅ 16.4 mm (for M16) 1 entry ∅ 20.5 mm (for M20) Thread length max. 9 mm	
		SA..U	US: 2 entries ∅ 21.5 mm for ½" tube connection	
	SA..61../MO	Fixed connecting cable	0.9m	-
	Number of wires	5 x 0.75 mm ²		
Degree of protection	Housing protection		IP 54 as per EN 60529	
	Insulation class		As per EN 60730	
	Actuators SA..31.. AC 230 V		II	
	Actuators SA..61.. AC / DC 24 V		III	
	Actuators SA..81.. AC / DC 24 V		III	
Environmental conditions	Operation		IEC 60721-3-3	
	Climatic conditions		Class 3K5	
	Mounting location		Indoors, outdoors ³⁾	
	Temperature general		-5...55 °C	
	Humidity (noncondensing)		5...95 % r. h.	
	Transport		IEC 60721-3-2	
	Climatic conditions		Class 2K3	
	Temperature		-25...70 °C	
	Humidity		<95 % r. h.	
	Storage		IEC 60721-3-1	
Temperature		-15...55 °C		
Humidity		5...95 % r. h.		
Directives and Standards	Product standard		EN60730-x	
	Electromagnetic compatibility (Application)		For residential, commercial and industrial environments	
	EU Conformity (CE)		SAS...: CE1T4581xx ⁴⁾ SAT...: CE1T4584xx ⁴⁾	
	RCM Conformity		SAS...: CE1T4581en_C1 ⁴⁾ SAT...: CE1T4584en_C1 ⁴⁾	
	UL, cUL AC / DC 24 V		UL 873 http://ul.com/database	
	EAC compliance		Eurasia compliance for all SA..-variants	
Environmental compatibility	The product environmental declaration CE1E4581 ⁴⁾ and A6V101083254 ⁴⁾ contains data on environmentally compatible product design and assessments (RoHS compliance, materials composition, packaging, environmental benefit, disposal).			
Dimensions	See Dimensions (page 62)			
Weight	Excl. packaging See Dimensions (page 62)			

Accessories ⁵⁾	Auxiliary switch ASC10.51 Switching capacity	AC 24...230 V, 6 (2) A, floating	
	External supply line protection	See section power supply	
	US installation, UL & cUL	AC 24 V class 2, 5 A general purpose	
Data sheet		N4581	N4584

¹⁾ Second value: Power consumption in neutral position

²⁾ AWG = American wire gauge

Wire cross-sectional areas and fuses have to be well-matching, which is the responsibility of the planner / installer. Observe norm of protection measures - protection against overcurrent: IEC 60364-4-43:2008 resp. german adoption HD 60364-4-43:2010.

³⁾ Outdoors always with weather shield ASK39.2, housing protection IP54 remains unchanged SA..61../MO is not suitable for outdoor applications.

⁴⁾ The documents can be downloaded from <http://siemens.com/bt/download>

⁵⁾ UL recognized component 

6 Connection diagrams and dimensions

6.1 Internal diagrams

SAS31.00
SAS31.03

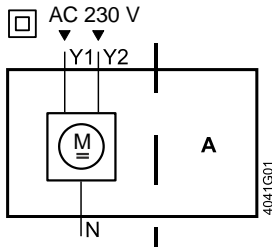

SAS31.50
SAS31.53
SAT31.51

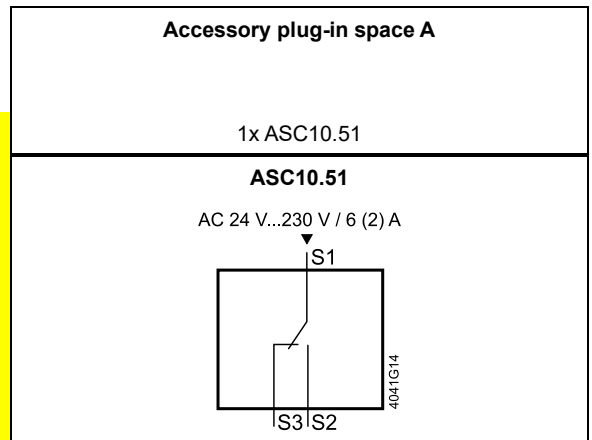
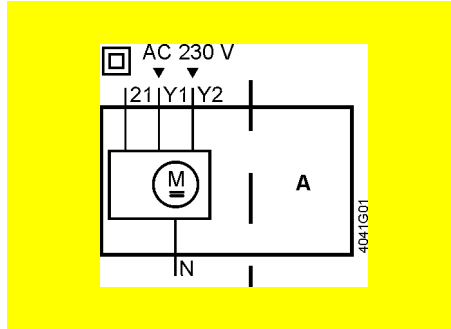

SAT31.008

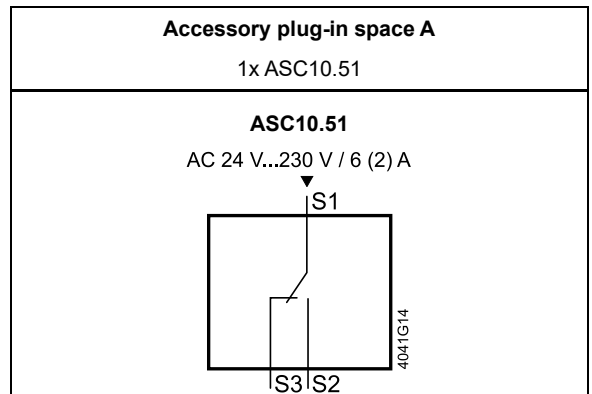
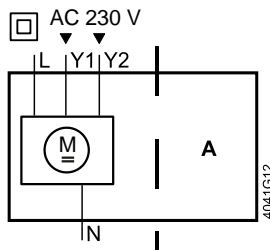

SAS61.03 (U)
SAS61.33(U)
SAS61.53
SAT61.008
SAT61.51

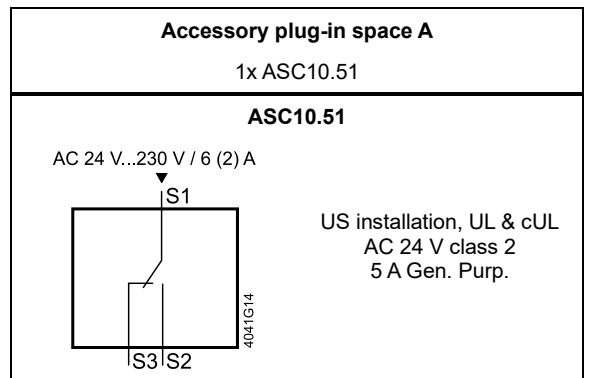
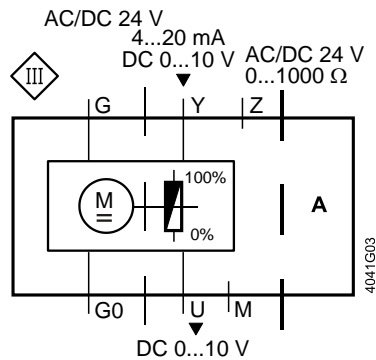

SAS61.03/MO
 SAS61.33/MO
 SAT61.008/MO
 SAT61.51/MO

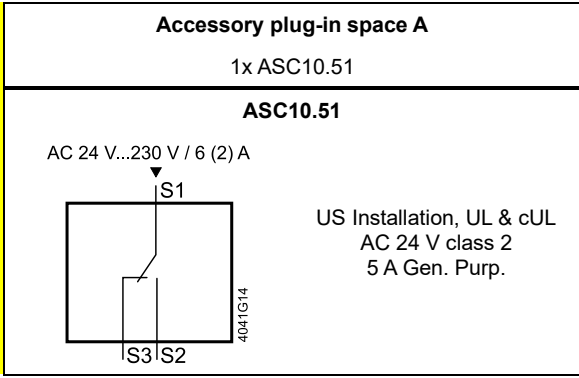
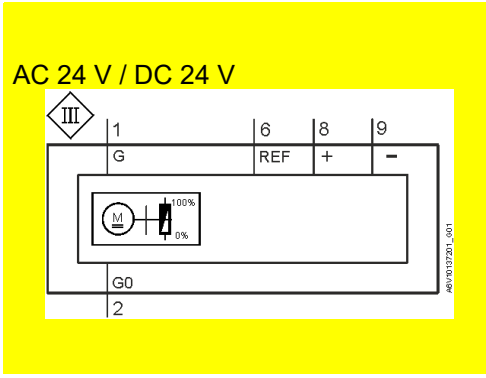

SAS81.00
 SAS81.03(U)

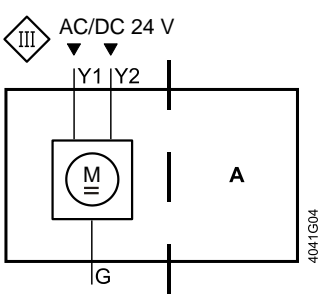

SAS81.33(U)

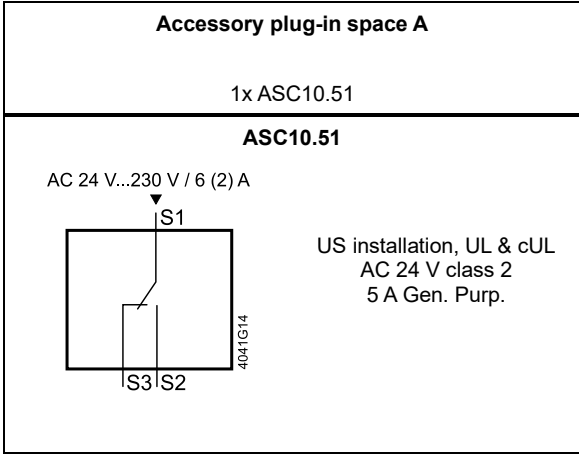
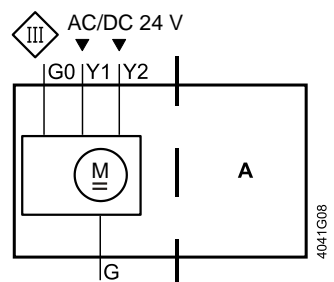

6.2 Connection terminals

6.2.1 Actuators

SAS31.00
SAS31.03

AC 230 V, 3-position

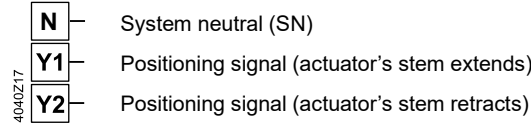

SAT31.008

AC 230 V, 3-position

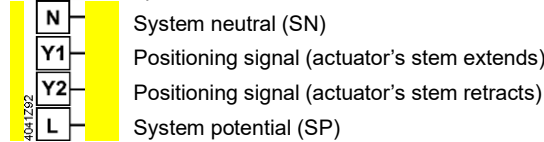

SAS31.50
SAS31.53
SAT31.51

AC 230 V, 3-position

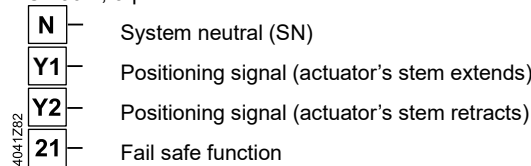

SAS61.03(U)
SAS61.33(U)
SAS61.53
SAT61.008
SAT61.51

AC/DC 24 V, DC 0...10 V / 4...20 mA / 0...1000 Ω

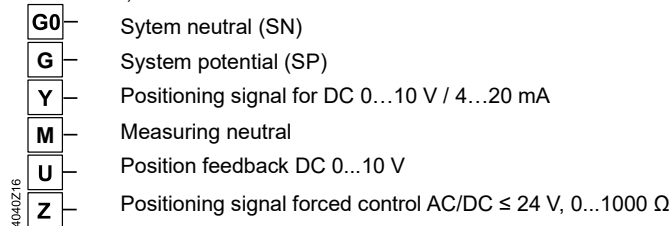

SAS61.03/MO
SAS61.33/MO
SAT61.008/MO
SAT61.51/MO

AC/DC 24 V, Modbus RTU connection cable

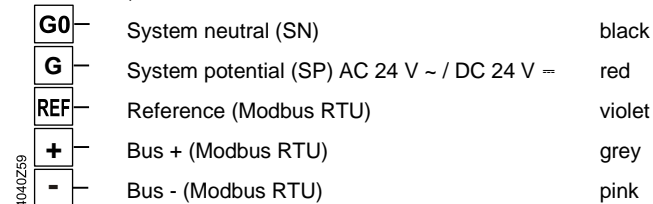

SAS81.00
SAS81.03(U)

AC/DC 24 V, 3-position

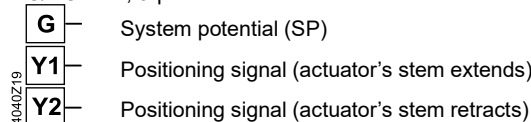

SAS81.33(U)

AC/DC 24 V, 3-position

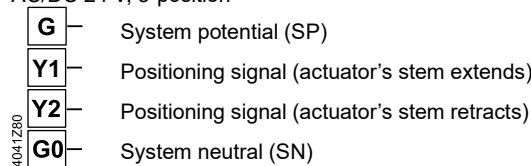

6.2.2 Electrical accessories

Auxiliary switch ASC10.51

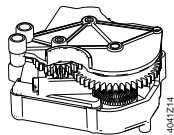

Adjustable switching points, AC 24...230 V

- 1 System potential (SP)
- 2 Closing (actuator's stem extends)
- 3 Opening (actuator's stem extends)

AC 24 V...230 V / 6 (2) A

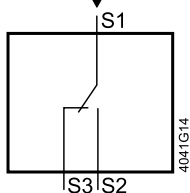

6.2.3 Cable labeling

The wires are color coded and labeled.

Connection	Cable				Description
	Code	No.	Color	Abbreviation	
Actuators AC 230V	N	4	blue	BU	System neutral
	Y1	6	black	BK	Positioning signal
	Y2	7	white	WH	Positioning signal
	L		-		System potential
	21		-		Fail safe function
Actuators AC 24 V resp. AC/DC 24 V	G	1	red	RD	System potential
	G0	2	black	BK	System neutral
	Y1	6	violet	VT	Positioning signal
	Y2	7	orange	OG	Positioning signal
	Y	8	grey	GY	Positioning signal
	M		-	-	Measuring neutral
	U	9	pink	PK	Position feedback
Z		-	-	Positioning signal forced control	
AC/DC 24 V, Modbus RTU connection cable	G	1	red	RD	System potential
	G0	2	black	BK	System neutral
	REF	6	violet	VT	Reference (Modbus RTU)
	+	8	grey	GY	Bus + (Modbus RTU)
	-	9	pink	PK	Bus - (Modbus RTU)

6.3 Connection diagrams

Warning

When using a safety limiter F1, ensure that there are no potential insulation mistakes to the wiring that could cancel out the temperature limiter's control action (applies to both 230 V as well as 24 V types).

Comply under all circumstances to the warning above when grounding SN (e.g. PELV).

SA..31..

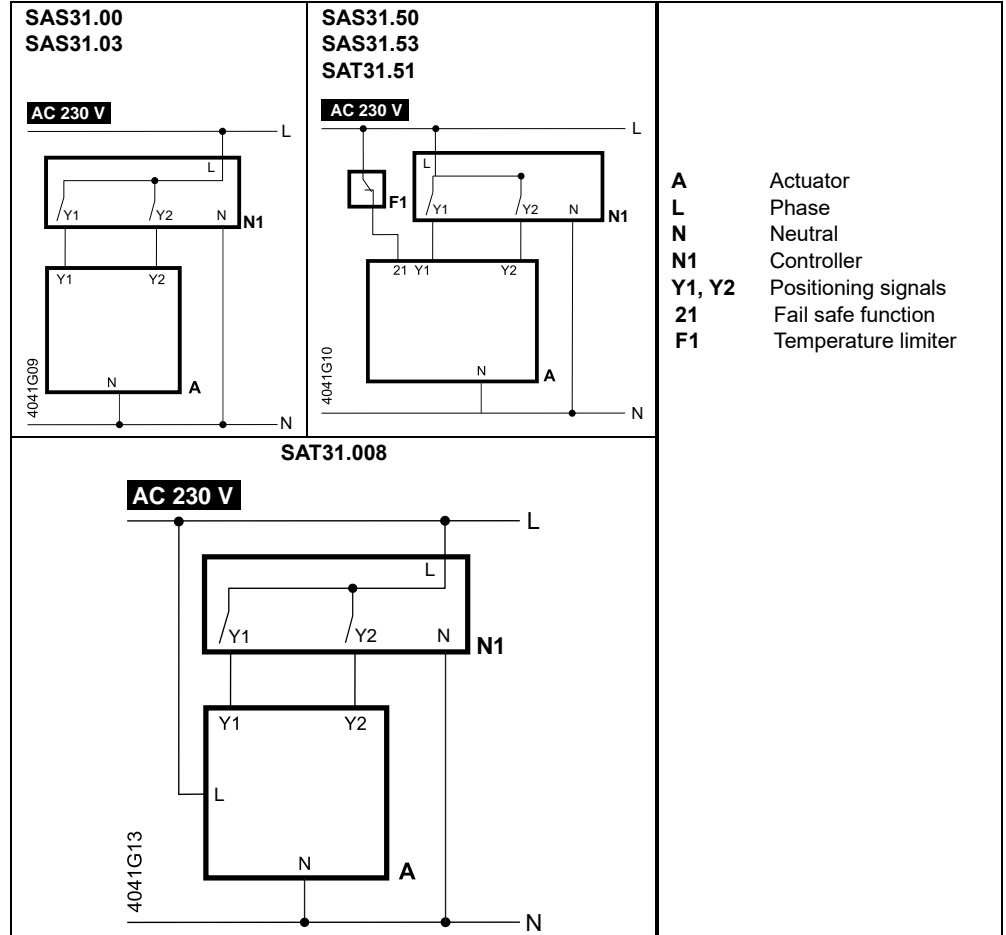

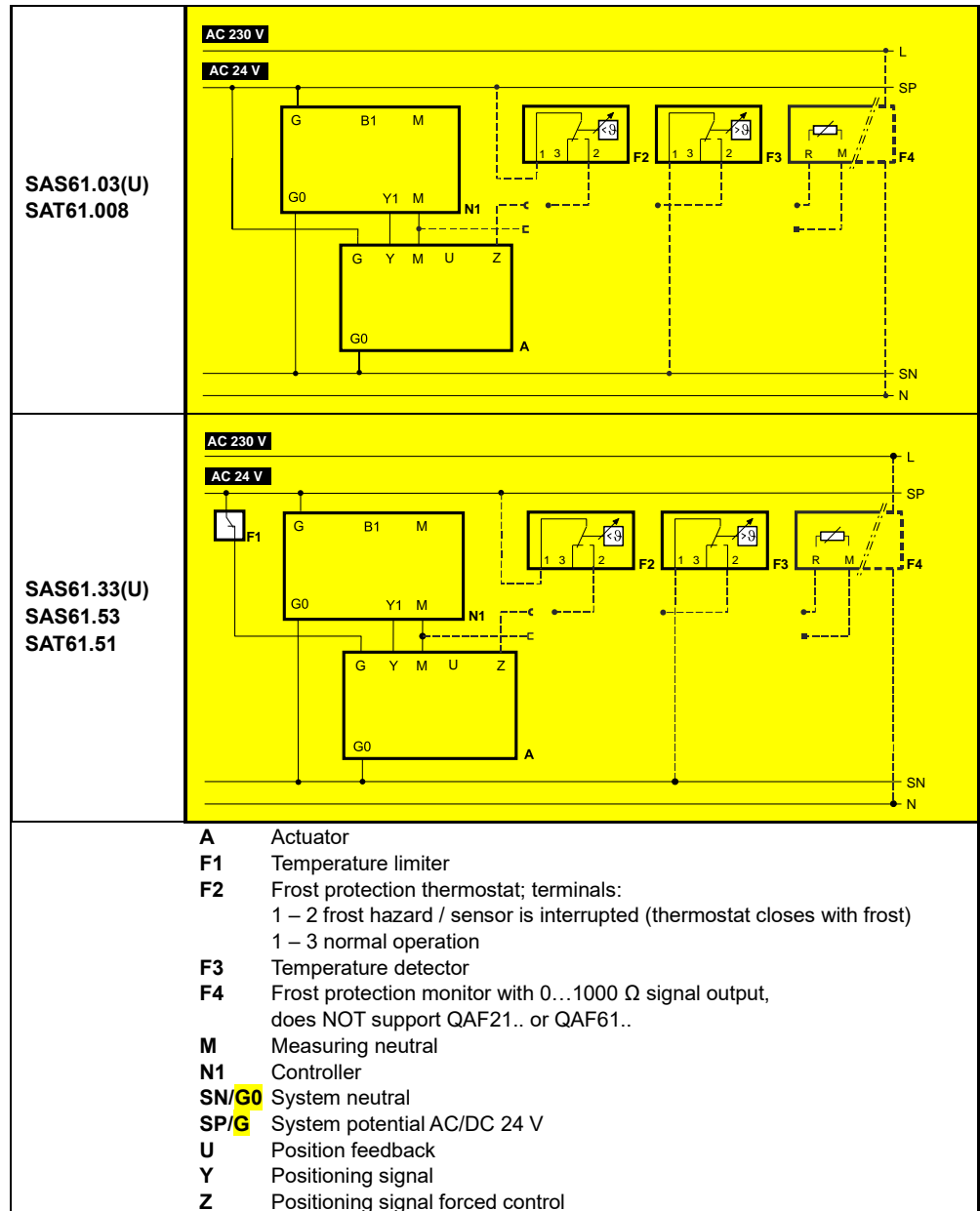

SA..61../MO

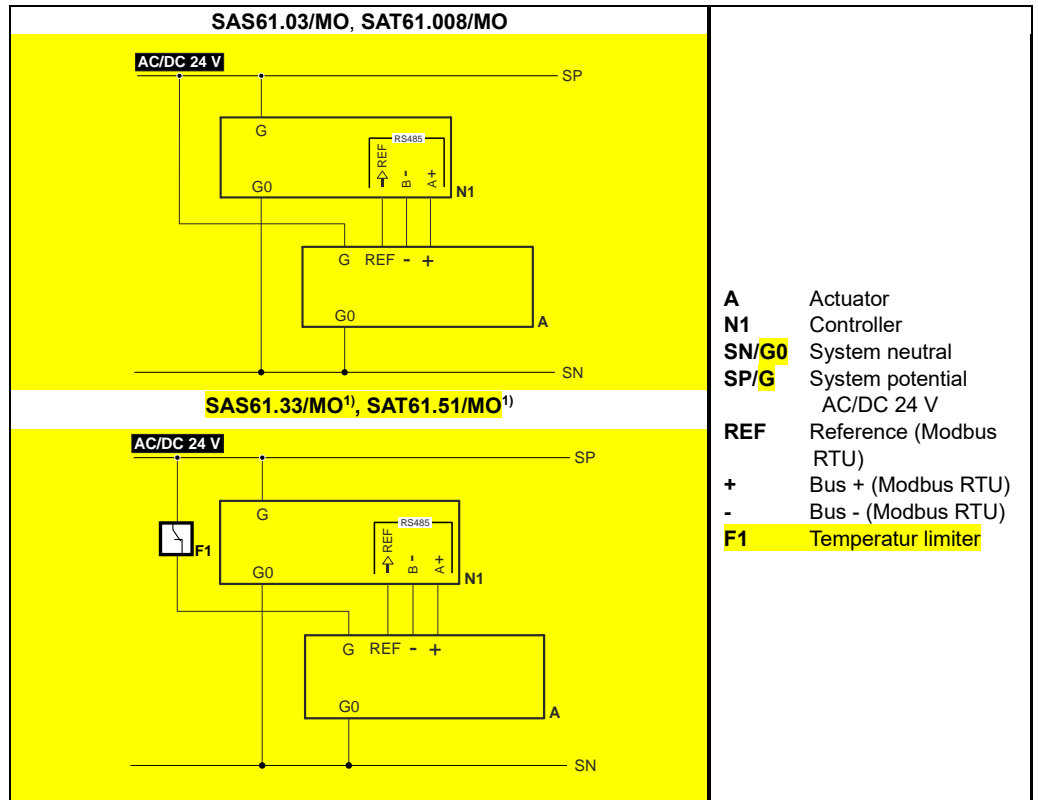

- A** Actuator
- N1** Controller
- SN/G0** System neutral
- SP/G** System potential
AC/DC 24 V
- REF** Reference (Modbus
RTU)
- +** Bus + (Modbus RTU)
- Bus - (Modbus RTU)
- F1** Temperatur limiter

¹⁾ When the temperature limiter is triggered, the drive can no longer be addressed via the bus.

SAS81..

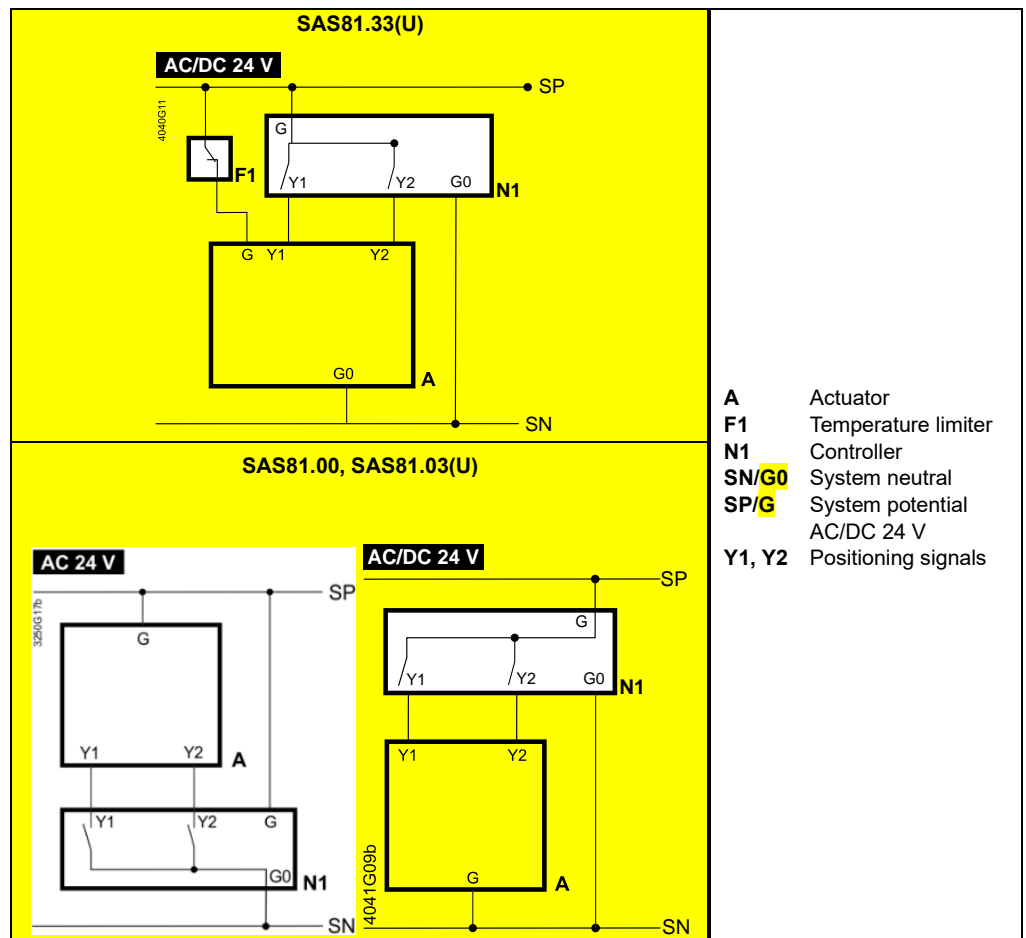

- A** Actuator
- F1** Temperature limiter
- N1** Controller
- SN/G0** System neutral
- SP/G** System potential
AC/DC 24 V
- Y1, Y2** Positioning signals

6.4 Dimensions

6.4.1 Stroke actuators

Stroke actuators SA.. with manual adjuster

Typ	A [mm]	B [mm]	C [mm]	C1 [mm]	C2 [mm]	D [mm]	E [mm]	F [Zoll]	▶ [mm]	▶▶ [mm]	kg [kg]	1	2
SAS.. / SAT..	151	80	93	21.9	71.1	29.9	21.8	G ¾	100	200	0.40	M16 ^{1) 3)}	M20 ^{1) 3)}
SA../MO ²⁾											0.55		
With ASK39.2:	155	126	248	99	149						0.55		

¹⁾ SA..U: ½" (Ø 21,5 mm)

²⁾ Device equipped with a fixed connection cable – Left cable entry is used

³⁾ Thread length max. 9 mm

Stroke actuators SA.. without manual adjuster

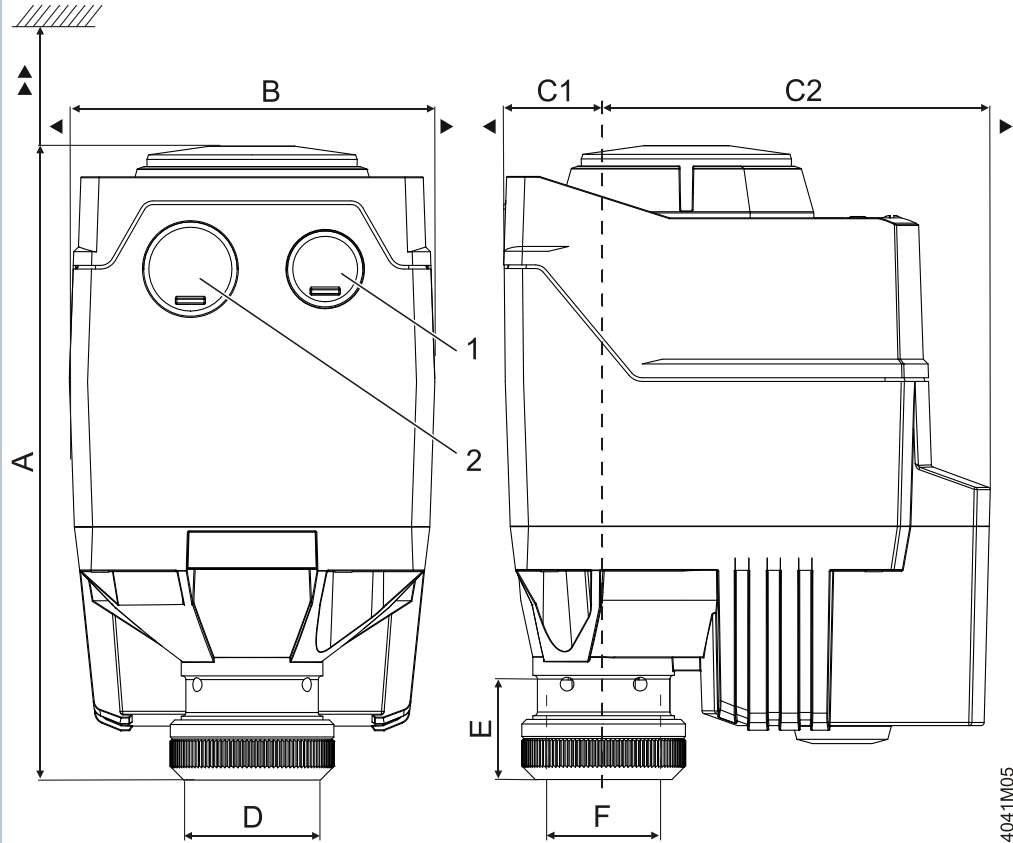

Typ	A [mm]	B [mm]	C [mm]	C1 [mm]	C2 [mm]	D [mm]	E [mm]	F [Zoll]	▶ [mm]	▶▶ [mm]	kg [kg]	1	2
SAS..	137.6 ¹⁾ 151 ²⁾	80	106.5	21.9	84.6	29.9	21.8	G ¾	100	200	0.68	M16 ³⁾	M20 ³⁾
Mit ASK39.2:	155	126	248	99	149						0.83		

- 1) Black cover
- 2) Blue manual adjuster
- 3) Thread length max. 9 mm

6.4.2 External Modbus Converter

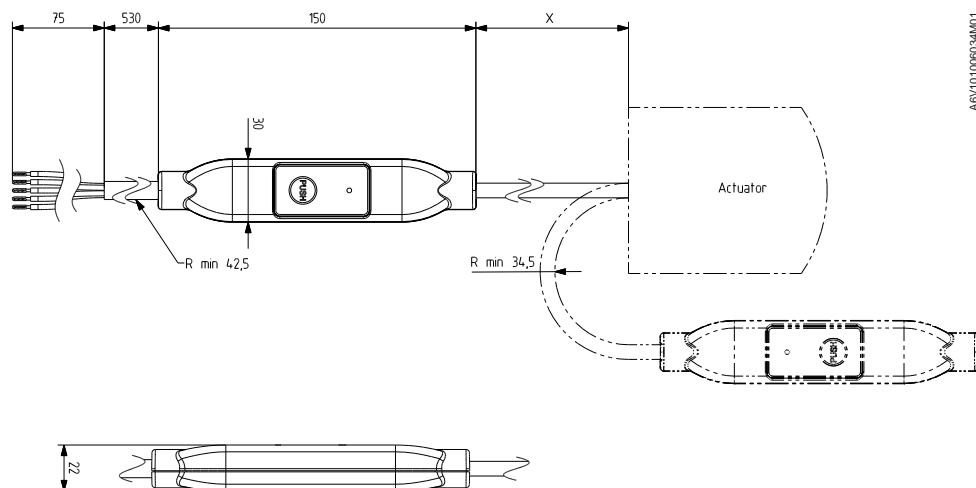

Type	X [mm]	 [kg]
SA../MO	250	0,15 ¹⁾

¹⁾ Already included in total weight

Dimensions in mm

Revision numbers

Product no.	Valid from rev. no.	Product no.	Valid from rev. no.	Product no.	Valid from rev. no.
SAS31.00	..B	SAT31.008	..B		
SAS31.03	..B	SAT31.51	..B		
SAS31.50	..B	SAT61.008	..B		
SAS31.53	..B	SAT61.008/MO	..A		
SAS61.03	..B	SAT61.51	..B		
SAS61.03U	..B	SAT61.51/MO	..A		
SAS61.03/MO	..B				
SAS61.33	..B				
SAS61.33U	..B				
SAS61.33/MO	..A				
SAS61.53	..B				
SAS81.00	..B				
SAS81.03	..B				
SAS81.03U	..B				
SAS81.33	..B				
SAS81.33U	..B				

7 Glossary

7.1 Symbols



Caution, general danger – read the notes!



Caution, hot surface – read the notes!

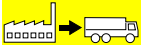

Condition as supplied to customer



Crosstip screwdriver (Pozidriv)

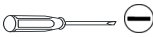

Slotted screwdriver



Screw wrench



Allen key

7.2 Terms

Climatix™

The complete product range of flexible and scalable control solutions, standardized up to and including freely programmable solutions. Specialized for HVAC applications.

ClosedPosition-Synchronisation

The Synchronisation of the mechanical position and the internal position control will be performed (after manual operation).

DIL switches

A DIL switch shows the switching choices in the form of a place value system (dual in line) in relation to basis 2 (on and off).

DN

Nominal size [mm]: Characteristic for matching parts of the piping system.

Fail safe function

The fail safe function ensures that the actuator is driven to a defined end position also in the event of a power failure or when the temperature limiter is triggered. In normal situations, dampers are shut or valves closed, thus cutting off the medium flow.

kPa

Unit of pressure: 100 kPa = 1 bar = 10 mWS.

k_{vs}

Nominal flow rate: Nominal flow rate of cold water (5...30 °C) through the fully open valve (H₁₀₀) at a differential pressure of 100 kPa (1 bar).

LED

Light emitting diode.

Idle stroke

The actuator stem lifts off the valve stem slightly (0.2 mm), so that the valve closed securely. If the valve opens again, this idle stroke has to be overcome, before the valve really opens (valve characteristic has an effect).

Modbus RTU	Open communications protocol (client/server architecture), transmits data as binary data. RTU: Remote Terminal Unit.
PN	PN class [bar]: Characteristic relating to the combination of mechanical and dimensional properties of a component in the piping system.
Position feedback	Signal used to acquire the position, fed back via an input.
Forced control	Forced control serves for overriding automatic mode and is implemented in the structure.
Δp_{\max} / $\Delta p_{\max V}$	Maximum permissible differential pressure across the valve's control path, valid for the entire actuating range of the motorized valve (V = diverting mode).
Δp_s	Maximum permissible differential pressure at which the motorized valve will close securely against the pressure (close off pressure).

8 Index

3-position control	33	Stroke actuators	16
A/D conversion	33, 36	Forced control.....	36, 42
About this documentation	5	Foreign bodies	41
Accessories	12	Foreign body detection	43, 45
Electrical accessories.....	12	Formulas for wire lengths.....	15
Mechanical accessories	12	Fremdkörperdetektion.....	44
Anschlussklemmen		Function check	26
Stetig	57	Function principle.....	48
Automatic operation.....	49	Functions.....	33
Auxiliary switch	19, 25, 28, 51, 58	Gear train	33, 36
Auxiliary switch ASC10.51.....	29, 30, 31	Glossary	65
Before you start	6	Handling.....	16
Brushless DC motor	33, 36	Housing cover	13
Cable entries	22	Housing of spring return.....	8
Cable glands	22	HVAC plants	7
Cable labeling	58	Identification of seat.....	33, 36
Calibration	26, 36, 39	Indicators.....	50
Calibration slot	36	Indoor use	16
Changeover of characteristic.....	36	Installation	16
Characteristics function	36	Interior view.....	18
Commissioning.....	26	Internal diagrams	55
Connection diagrams.....	55, 59	Kopplung	48
Connection terminal.....	57	L/P-diagram	15
Actuator	57	LED.....	36
Electrical accessories.....	58	Maintenance	28, 32
Contents	3	Manual adjuster	8, 9, 33, 36, 49
Control	33	Manual operation	49
Control functions.....	33, 36	Mechanical accessories.....	51
Control of direction	33	Mechanical design.....	48
Copyright.....	6	Modbus RTU.....	28
Cross-sectional area	15	Modulating control	36
Delivery.....	10	Motor control.....	33, 36
Detection of foreign bodies	36, 41, 43	Mounting.....	16
Detection of valve seat.....	41	Mounting positions.....	16
Deviations.....	34	Navigation	5
DIL switch.....	36, 38	Operating voltage	9, 15
Dimensions	62	Operation	26
Stroke actuators	62, 64	Operational status	50
Disposal.....	32	Ordering.....	9
Document use.....	7	Outdoor use	16
Electrical accessories	51	Parallel operation.....	14
Electrical connections	8	Permissible cable length.....	14
Electrical planners.....	7	Permissible voltage drop	15
Engineering.....	8	Permissible wire length.....	15
Equipment combinations		Plug-in space	19
2-port threaded valves	11	Position control	36
3-port threaded valves	11	Position feedback.....	9, 39
3-port valves.....	11	Position indication.....	8, 50
Fail safe function	9, 33, 36, 40, 48	Positioning signal.....	9, 26, 28, 33, 36, 37, 38
Fitting		Positioning time.....	9, 34
Accessories.....	18	Power consumption	9, 15

Power supply	36	Symbols	65
Power transmission.....	8	Technical data	52
Print.....	8	Technical design	42, 48
Product description.....	8	Technology	42
Product replacements	12	Terms.....	65
Electrical accessories.....	13	Trademarks	6
Stroke actuators SQX.. zu SAX..	13	Transmission of power.....	48
Quality assurance.....	6	Type summary	
Reference documents	5	Stroke actuators	9
Request to the reader.....	7	Use.....	9
Revision history.....	5	User interface	8
Revision numbers.....	64	Valve seat detection.....	42
Scope of this documentation	7	voltage drop	14
Signal priorities.....	40	Volumendurchfluss.....	38
Without fail safe	46, 47	Warranty.....	15
Signal prioritites		Weather shield	12, 16, 21, 51, 54, 62
Without fail safe	46	Wire cross-sectional area	14
Sizing	14	Wire endings	22
Spare parts	13	Wiring	20, 22
Status indication.....	8	Yoke.....	8
Stroke model	34		