

## Powermite 599 Series

### MZ Series Zone Control Three-way Valves

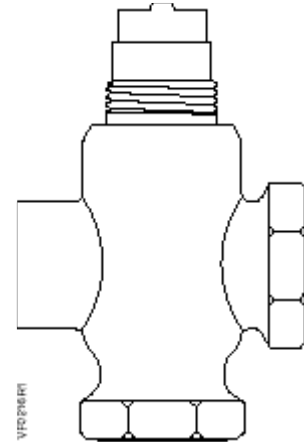

**Description** The Powermite 599 Series ANSI Class 250 MZ Series three-way valves are designed to work the SSB MZ Series actuator with a 7/32-inch (5.5 mm) stroke.

**Features** Direct coupled universal bonnet  
ANSI Leakage Class IV (0.01% of Cv)

**Application** A typical application for the Powermite three-way valve is the mixing of hot or chilled water for convectors, fan coil units, unit conditioners, radiation, reheat coils, and similar terminal units requiring an actuator that delivers a minimum of 45 pounds force (200 N).

**Product Numbers** **Table 1. Product Numbers.**

| Flow Rate |        | Line Size |      | Product   |
|-----------|--------|-----------|------|-----------|
| Cv        | (Kvs)  | inch      | (mm) | Number    |
| 0.4       | (0.34) | 1/2       | (15) | 599-01132 |
| 0.63      | (0.54) | 1/2       | (15) | 599-01133 |
| 1         | (0.85) | 1/2       | (15) | 599-01134 |
| 1.6       | (1.37) | 1/2       | (15) | 599-01135 |
| 2.5       | (2.15) | 1/2       | (15) | 599-01136 |
| 4         | (3.44) | 1/2       | (15) | 599-01137 |
| 6.3       | (5.43) | 3/4       | (20) | 599-01138 |
| 10        | (8.6)  | 1         | (25) | 599-01139 |

**Ordering a Valve Plus Actuator Assembly**

To order a complete valve plus actuator assembly from the factory, combine the actuator prefix code with the suffix of the valve assembly product number. See *Technical Bulletin (TB) 252 (155-307P25)* for selection procedure and ordering codes.

Valve assemblies can be ordered using the numbers in Table 1.

**Specifications**

|                      |                                 |
|----------------------|---------------------------------|
| Line size            | 1/2 to 1 inch (15 to 25 mm)     |
| Capacity             | See Tables 3 and 4 and Figure 1 |
| Body style           | Globe                           |
| Seat style           | Metal-to-metal                  |
| Action               | Three-way mixing                |
| Valve body rating    | ANSI Class 250; See Table 2     |
| Stem travel (Stroke) | 7/32-inch (5.5 mm)              |

**Material**

|           |  |
|-----------|--|
| Body      | UNS CA844 bronze<br>or forged brass C37700 |
| Body trim | Brass                                      |
| Stem      | Stainless steel ASTM A582 Type 303         |
| Packing   | Ethylene propylene O-ring                  |

**Operating**

|  |                                |
|--|--------------------------------|
| Controlled medium  | Water, glycol solutions to 50% |
| Medium temperature range   | 35°F to 250°F (2°C to 120°C)   |
| Maximum inlet pressure   | See Table 2                    |
| Maximum recommended differential pressure for modulating service | 25 psi (173 kPa)               |
| Rangeability   |                                |
| Cv <1  | >50:1                          |
| Cv >1  | >100:1                         |
| Close-off pressures  | See Table 5 and Figure 2       |
| Close-off ratings  | According to ANSI/FCI 70-2     |
| Leakage rate   | Class IV (0.01% of Cv)         |
| Flow characteristics   | Linear                         |

**Miscellaneous**

|                               |  |
|-------------------------------|--|
| Canadian Registration Numbers | 0C24303.5                              |
| Mounting location             | NEMA 1 (interior only)                 |
| Dimensions                    | See Tables 6 and 7 and Figures 4 and 5 |
| Valve Weight                  | See Table 6                            |

**Service Kit**

Protective black knob to cover the bonnet and threads



4 268 8895 0

**Table 2. Body Temperature-Pressure Rating.**

| Valve Body             | Temperature |             | Pressure psig (kPa) |
|------------------------|-------------|-------------|---------------------|
|                        | F°          | C°          | ANSI Class 250      |
| Bronze or Forged Brass | -20 to +150 | (-30 to 66) | 400 (2758)          |
|                        | +200        | (93)        | 385 (2655)          |
|                        | +250        | (121)       | 365 (2586)          |
|                        | +300        | (149)       | 335 (2300)          |
|                        | +350        | (177)       | 300 (2068)          |

**Table 3. Maximum Water Capacity - U.S. Gallons per Minute.**

| Valve Size in inches | Pressure Differential - psi |      |      |      |      |      |      |      |      |      |      |      |      |      |      |      |
|----------------------|-----------------------------|------|------|------|------|------|------|------|------|------|------|------|------|------|------|------|
|                      | Cv\1                        | 2    | 3    | 4    | 5    | 6    | 8    | 10   | 15   | 20   | 25   | 30   | 40   | 50   | 60   | 75   |
| 1/2                  | 0.4                         | 0.6  | 0.7  | 0.8  | 0.9  | 1.0  | 1.1  | 1.3  | 1.5  | 1.8  | 2.0  | 2.2  | 2.5  | 2.8  | 3.1  | 3.5  |
|                      | 0.63                        | 0.9  | 1.1  | 1.3  | 1.4  | 1.5  | 1.8  | 2.0  | 2.4  | 2.8  | 3.2  | 3.5  | 4.0  | 4.5  | 4.9  | 5.5  |
|                      | 1.0                         | 1.4  | 1.7  | 2.0  | 2.2  | 2.5  | 2.8  | 3.2  | 3.9  | 4.5  | 5.0  | 5.5  | 6.3  | 7.1  | 7.8  | 8.7  |
|                      | 1.6                         | 2.3  | 2.8  | 3.2  | 3.6  | 3.9  | 4.5  | 5.1  | 6.2  | 7.2  | 8.0  | 8.8  | 10.1 | 11.3 | 12.4 | 13.9 |
|                      | 2.5                         | 3.5  | 4.3  | 5.0  | 5.6  | 6.1  | 7.1  | 7.9  | 9.7  | 11.2 | 12.5 | 13.7 | 15.8 | 17.7 | 19.4 | 22   |
|                      | 4                           | 5.7  | 7    | 8.0  | 8.9  | 10   | 11.3 | 12.6 | 15.5 | 17.9 | 20.0 | 21.9 | 25   | 28   | 31   | 35   |
| 3/4                  | 6.3                         | 8.9  | 10.9 | 12.6 | 14.1 | 15.4 | 17.8 | 20   | 24   | 28   | 32   | 35   | 40   | 45   | 49   | 55   |
| 1                    | 10                          | 14.1 | 17.3 | 20   | 22   | 24   | 28   | 32   | 39   | 45   | 50   | 55   | 63   | 71   | 77   | 87   |

**Table 4. Maximum Water Capacity - Cubic Meters per Hour (m<sup>3</sup>/hr).**

| Valve Size in mm | Pressure Differential - kPa |      |      |      |      |      |      |      |         |      |      |      |      |      |  |
|------------------|-----------------------------|------|------|------|------|------|------|------|---------|------|------|------|------|------|--|
|                  | 1                           | 10   | 20   | 30   | 40   | 50   | 60   | 80   | Kvs/100 | 150  | 200  | 300  | 400  | 500  |  |
| 15               | 0.03                        | 0.11 | 0.15 | 0.19 | 0.22 | 0.24 | 0.26 | 0.30 | 0.34    | 0.42 | 0.48 | 0.59 | 0.68 | 0.76 |  |
|                  | 0.05                        | 0.17 | 0.24 | 0.30 | 0.34 | 0.38 | 0.42 | 0.48 | 0.54    | 0.66 | 0.76 | 0.94 | 1.08 | 1.21 |  |
|                  | 0.09                        | 0.27 | 0.38 | 0.47 | 0.54 | 0.60 | 0.66 | 0.76 | 0.85    | 1.0  | 1.2  | 1.5  | 1.7  | 1.9  |  |
|                  | 0.14                        | 0.43 | 0.61 | 0.75 | 0.87 | 0.97 | 1.06 | 1.23 | 1.37    | 1.7  | 1.9  | 2.4  | 2.7  | 3.1  |  |
|                  | 0.21                        | 0.68 | 0.96 | 1.17 | 1.35 | 1.51 | 1.66 | 1.91 | 2.15    | 2.6  | 3.0  | 3.7  | 4.3  | 4.8  |  |
|                  | 0.34                        | 1.1  | 1.5  | 1.9  | 2.2  | 2.4  | 2.7  | 3.1  | 3.4     | 4.2  | 4.9  | 6.0  | 6.9  | 7.7  |  |
| 20               | 0.54                        | 1.7  | 2.4  | 3.0  | 3.4  | 3.8  | 4.2  | 4.9  | 5.4     | 6.7  | 7.7  | 9.4  | 10.9 | 12.1 |  |
| 25               | 0.86                        | 2.7  | 3.8  | 4.7  | 5.4  | 6.1  | 6.7  | 7.7  | 8.6     | 10.5 | 12.2 | 14.9 | 17.2 | 19.2 |  |

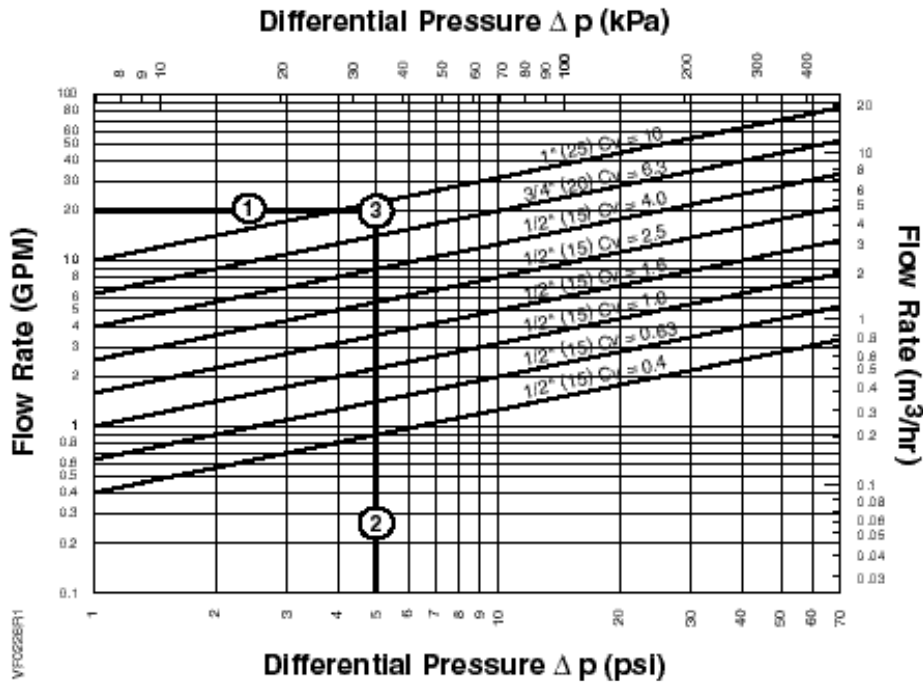

Figure 1. Water Capacity Graph.

**Selection Example**

Select a valve given:

See Figure 1.

- ① Required flow = 20 gpm.
- ② Desired pressure drop = 5 psi.
- ③ Choose a 1-inch (25 mm) valve, Cv 10.

Table 5. Close-off Pressures.

| Action            | Valve Size Inches (mm)                             | SSB Actuator<br>psi (kPa) |
|-------------------|--|---------------------------|
| NC<br>Upper port  | 1/2", 0.4 < Cv < 1.6<br>(15 mm, 0.34 < Kvs < 1.37) | 70 (483)                  |
|                   | 1/2", 2.5 < Cv < 4<br>(15 mm, 2.15 < Kvs < 3.44)   | 40 (276)                  |
|                   | 3/4" and 1" (20 mm and 25 mm)                      | 30 (207)                  |
| NO<br>Bottom port | 1/2", 0.4 < Cv < 1.6<br>(15 mm, 0.34 < Kvs < 1.37) | 25 (172)                  |
|                   | 1/2", 2.5 < Cv < 4<br>(15 mm, 2.15 < Kvs < 3.44)   | 15 (103)                  |
|                   | 3/4" and 1" (20 mm and 25 mm)                      | 10 (69)                   |

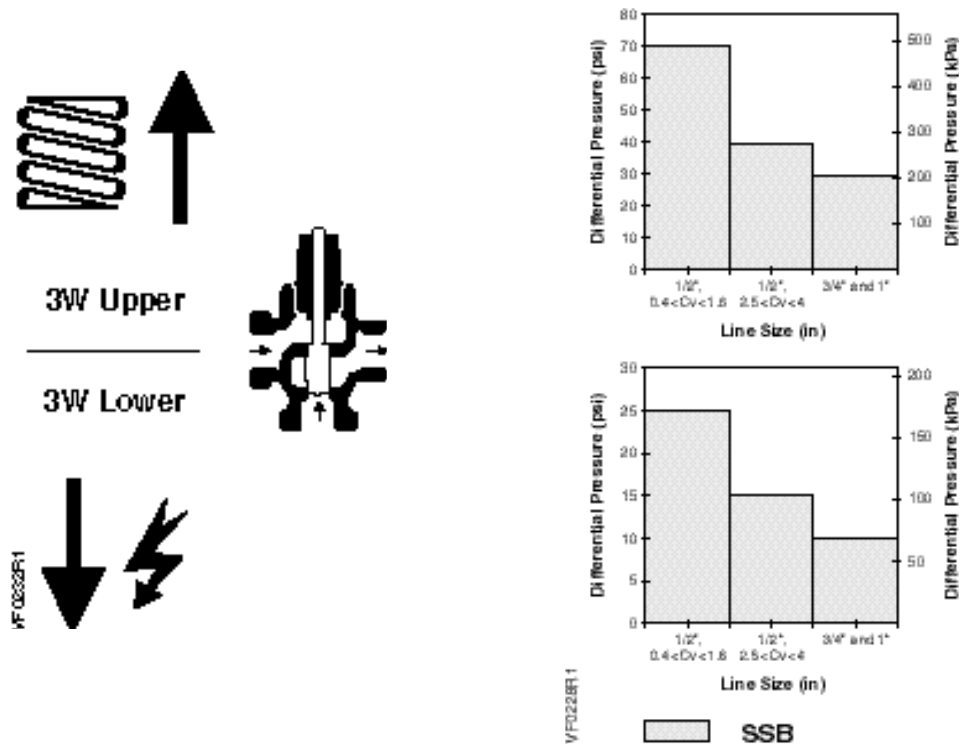

Figure 2. Close-off Pressures.

**Operation**

As the valve stem moves downward, the flow through the NO port decreases and the flow through the NC port increases. As the valve stem moves upward, the flow through the NO port increases and the flow through the NC port decreases.

In the event of power failure, a fail-safe actuator returns the valve to its normal position. Fail-in-place actuators will hold the last commanded position. See the Technical Instructions of the various actuators for additional information.

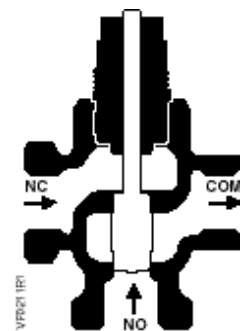

Figure 3.

**Sizing**

The sizing of a valve is important for correct system operation. An undersized valve will not have sufficient capacity at maximum load. An oversized valve can initiate cycling, and the seat and throttling plug can be damaged because of the restricted opening. Correct sizing of the control valve for actual expected conditions is considered essential for good control.

The following variables must be determined:

- The medium to be controlled: water, etc.
- The maximum inlet temperature and pressure of the medium at the valve.
- The pressure differential that will exist across the valve under maximum load demand.

## Sizing, Continued

- The maximum capacity the valve must deliver.
- The maximum line pressure differential the valve actuator must close against.

See *Application Bulletin (AB)-1 Control Valve Selection and Sizing (155-285)* for further recommendations.

See Tables 3 and 4 for valve capacities.

## Mounting and Installation

Install the valve so that the flow follows the direction of the arrow indicated on the valve body.

For best performance, install the valve assembly with the actuator above the valve body. The valve and actuator can be installed in any position between vertical and horizontal. It is not recommended to install the valve assembly so that the actuator is below horizontal or up side down.

Allow sufficient space for servicing the valve and actuator. See Table 6 for valve body dimensions. See Figure 5 and Table 7 for dimensions of the service envelope recommended around the actuator.

**NOTE:** Instructions for field mounting an actuator, wiring diagrams, and start-up are covered in the Technical Instructions and Installation Instructions for each actuator.

## Service

Replace the valve if inoperable.

## Dimensions

See Table 6 for valve body dimensions. The letters in Figure 5 refer to the valve centerline to top of actuator, the actuator width, and service envelope dimensions in Table 7.

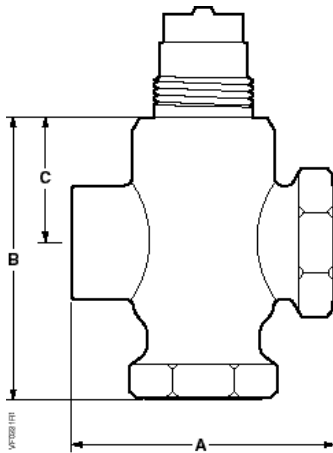

Figure 4. Three-way Valve.

Table 6. Three-way Valve Dimensions.

| Valve Size<br>inch (mm) | A             | B               | C              | Weight<br>lb (kg) |
|-------------------------|---------------|-----------------|----------------|-------------------|
| 1/2<br>(15)             | 2-3/4<br>(70) | 2-15/16<br>(74) | 1-5/16<br>(33) | 1.10<br>(0.5)     |
| 3/4<br>(20)             | 3-1/4<br>(83) | 3-9/16<br>(90)  | 1-5/16<br>(33) | 1.44<br>(.65)     |
| 1<br>(25)               | 3-7/8<br>(98) | 3-15/16<br>(99) | 1-9/16<br>(39) | 2.20<br>(1.0)     |

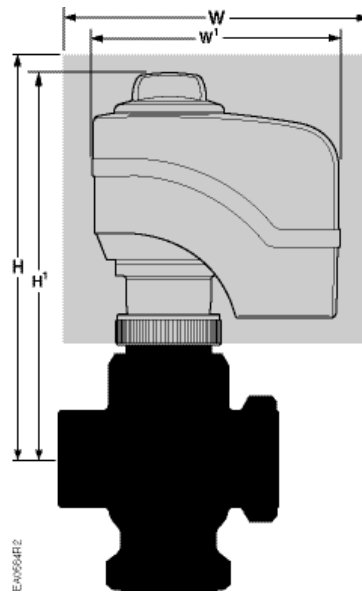
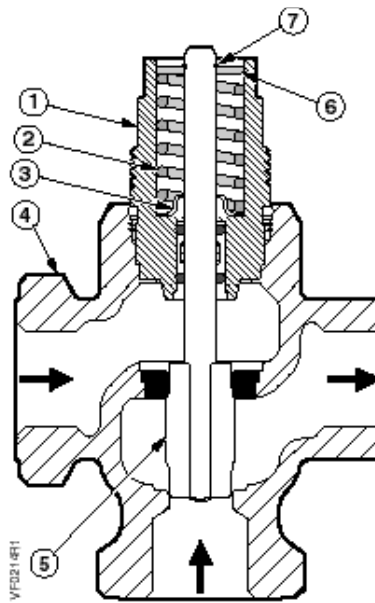

Figure 5.

**Table 7. Dimensions of the Actuator and Recommended Service Envelope.  
 Dimensions in Inches (Millimeters).**

| Actuator | Actuator Prefix Code | Valve line Size | Center line to Top of Actuator, H1 | Service Height H | Actual width of the Actuator W1 | Service Width W |
|----------|----------------------|-----------------|------------------------------------|------------------|---------------------------------|-----------------|
| SSB      | 254<br>255           | 1/2 (15)        | 4-7/8 (124)                        | 13-1/8 (330)     | 3-1/4 (83)                      | 11-1/4 (282)    |
|          |                      | 3/4 (20)        | 4-7/8 (124)                        | 13-1/8 (330)     | 3-1/4 (83)                      | 11-1/4 (282)    |
|          |                      | 1 (25)          | 5-1/8 (130)                        | 13-3/8 (335)     | 3-1/4 (83)                      | 11-1/4 (282)    |

## Parts Of the Valve



**Table 8. Three-way Bronze/Forged Brass Valves.**

| Item | Part Name              | Part No. | Q'ty | Material                 |
|------|------------------------|----------|------|--------------------------|
| 1    | Bonnet Ass'y           | —        | 1    | —                        |
| 2    | Spring                 | —        | 1    | Stainless steel          |
| 3    | Wiper                  | —        | 1    | Nylon                    |
| 4    | Valve Body             | —        | 1    | Bronze or Forged Brass   |
| 5    | Stem and Plug Assembly | —        | 1    | Stainless steel or brass |
| 6    | Upper guide disc       | —        | 1    | Brass                    |
| 7    | Retaining ring         | —        | 1    | Stainless steel          |

Information in this publication is based on current specifications. The company reserves the right to make changes in specifications and models as design improvements are introduced. Other product or company names mentioned herein may be the trademarks of their respective owners.  
 © 2005-2023 Siemens Industry, Inc.