

Powers™ Controls

No. 6 Damper Actuators – Tandem Mounting



Description	The No. 6 Damper Actuators - Tandem Mounting consist of two No. 6 actuators piloted by a positioning relay mounted on a sturdy angle iron frame.	
Features	<ul style="list-style-type: none"> • Spring span and start point are adjustable • Actuators have spring return • Diaphragms are replaceable 	
Application	The No. 6 Damper Actuators - Tandem Mounting is recommended to position inlet vanes on fans or large dampers that use a jackshaft.	
Product Number	331-3070	
Service Kits	Silicone diaphragms (package of 5)	333-572
Specifications	Effective diaphragm area	35.8 inch ² (230 cm ²)
	Stroke	4 inch (102 mm)
	Diaphragm	Ozone-resistant silicone rubber
	Maximum air pressure	30 psig (210 kPa)
	Spring start point-adjustable	3 to 10 psig (21 to 69 kPa)
	Spring span-adjustable	3 to 10 psig (21 to 69 kPa)
	Spring range-factory setting	3 to 13 psig (21 to 90 kPa)
	Ambient temperature range	
	Operating	-20°F to 200°F (-29°C to 93°C)
	Air connection	1/8-inch NPT
	Type of mounting	Pivot
	Torque rating	See Figure 1
	Damper area rating	See Table 1

Accessories		
Spring Clamp (secures 1/4-inch OD poly tubing to barb-fitting at higher control pressure)		531-833
Actuator Extension Kit		333-030
Crank Kit		331-535

Warning/Caution Notations



WARNING:		Personal injury, or loss of life may occur if you do not follow a procedure as specified.
CAUTION:		Equipment damage, or loss of data may occur if you do not follow a procedure as specified.

Table 1. Damper Area Ratings (See NOTE).

Maximum Airflow Velocity ft/min (m/sec)	Torque Per Unit Of Damper Area lb. in/ft ² (Nm/m ²)	Maximum Damper Area ft ² (m ²)	
		Air Supply To Positioner 18 psig (124 kPa)	Air Supply To Positioner 25 psig (172 kPa)
1200 (6.1)	1.25 (0.14)	200 (18.6)	324 (30.1)
1200 (6.1)	5.0 (0.57)	50 (4.6)	81 (7.5)
2000 (10.2)	2.0 (0.23)	124 (11.5)	202 (18.8)
2000 (10.2)	5.0 (0.57)	50 (4.6)	81 (7.5)

NOTE: Based on 4-inch (102) actuator stroke, 2.8-inch (71 mm) crank arm, and 90° damper rotation.

Sizing

For Dampers

- The number of actuators required to operate a damper depends on several factors: torque rating per unit of damper area, air velocity across the damper, and the quality and installation of the damper.
- The sizing information is based on the assumption that the dampers are properly installed so the linkage and blades move freely.
 1. Determine the variables for air velocity, damper torque per unit of area, and positioner air supply.
 2. Once these values are known, use Table 1 to determine the damper area that can be controlled by one actuator assembly.
 3. If damper rotation is other than 90°, use Figure 1 and Table 2 to determine the actuator assembly torque rating. Then, divide actuator assembly torque rating by damper torque rating per unit of area for job conditions to determine damper area that can be controlled. Make sure the torque units used are the same.

NOTE: Crank (Lever) is not provided.



CAUTION:

The torque per unit of damper area for low leakage dampers can be very high. Make sure this actuator is selected accurately.

Sizing, Continued
For Inlet Vane Dampers

- Most inlet vane dampers have a torque rating for closing or opening the vanes at various air velocities.
- The majority of inlet vane dampers rotate through 90° from open to close.
- Most have a lever or crank arm with a series of holes for different angles of rotation. The clevis provided should be connected to the appropriate hole.

NOTE: For 1/2-inch (13 mm) diameter damper shaft and 47-inch rotation, use the 331-535 crank kit. Holes for other angles of rotation can be drilled in the crank.

Determine torque requirements of inlet vane damper and angular rotation required.

Select lever or crank arm length from Table 2 based on required inlet vane damper rotation.

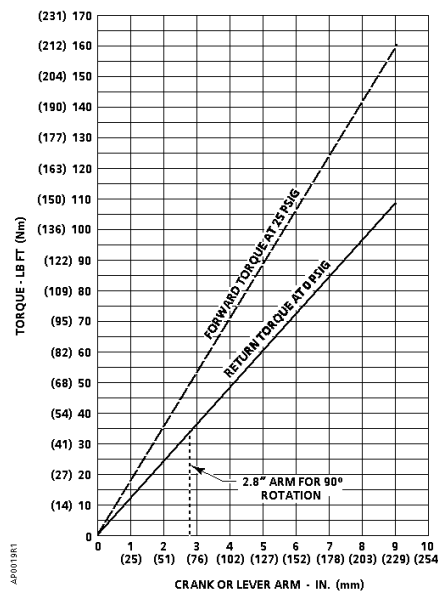

Figure 1. Torque Rating.

3. Figure 1 shows the forward and return torque. Determine which is most important for the application. Frequently, return torque is used for closing and forward torque for opening. In Figure 1, follow crank or lever arm length line up to the torque curve selected to determine the torque rating of the actuator assembly.
4. Compare torque rating of inlet vanes to torque rating of actuator assembly to determine suitability.

Installation

1. Install dampers to enable inlet vanes or damper blades and linkage move freely.
2. Select location for the actuator assembly that will allow the linkage to operate the damper or inlet vanes without obstruction.
3. Attach the angle iron frame of the actuator assembly to the mounting surface with appropriate fasteners. (See Figure 3.)

**Installation,
 continued**

4. Determine the length “L” (NPT pipe length) shown in Figure 2 required for the application. Increase the length “L” by the amount of thread engagement at each end of the pipe.
5. Obtain locally the required length of pipe with 1/2-inch NPT threads at each end.

The installation is now complete.

Table 2. Arm Length Versus Rotation (See Figure 1)

Lever or Crank Arm Length in. (mm)	Damper Rotation In Degrees
2.3 (58)	120
2.8 (71)	90
3 (76)	84
4 (102)	60
5 (127)	47
6 (152)	39
7 (178)	33
8 (203)	29
9 (229)	25

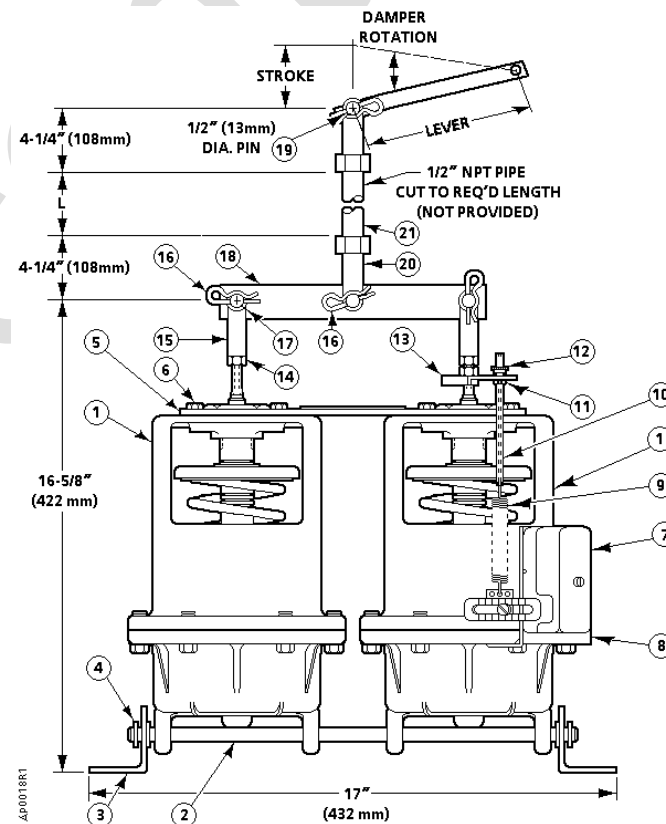

Figure 2. Damper or Inlet Vane Installation.

**Installation,
Continued**

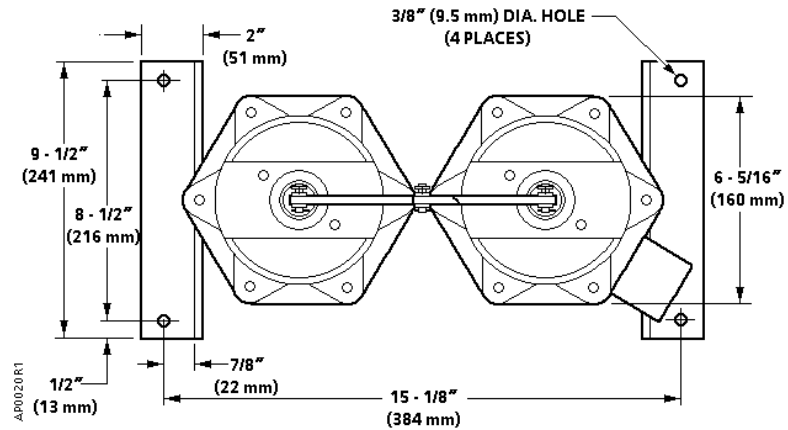

Figure 3. Damper or Inlet Vane Mounting Hole Locations (Top View).

Table 3. (See Figure 2).

Item	Description	Quantity
1	No. 6 Actuator	2
2	Pivot Shaft	1
3	Angle Iron Frame	2
4	"E" Ring	4
5	Stabilizing Plate	1
6	Cap Screw 5/16 - 18 Thread	4
7	Positioning Relay	1
8	Mounting Bracket	1
9	Feedback Spring	1
10	Adjustment Screw	1
11	Nut 10 - 24 Thread	1
12	Adjustment Nut	1
13	Spring Arm	1
14	Nut 3/8 - 24 Thread	4
15	Clevis	2
16	Cotter Pin	4
17	Clevis Pin	2
18	Load Bar	1
19	Clevis Pin	2
20	Clevis	2
21	Adapter	2

Information in this publication is based on current specifications. The company reserves the right to make changes in specifications and models as design improvements are introduced. Powers is a trademark of Siemens Building Technologies, Inc. Other product or company names mentioned herein may be the trademarks of their respective owners. © 2003 Siemens Building Technologies, Inc.