

599 Series Zone Valve Actuator

SSA81U 24 Vac Electronic Valve Actuator: Floating Control Fail-in-Place

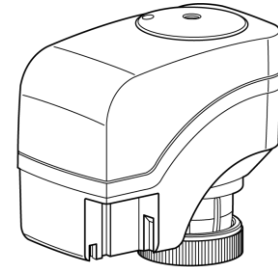

EA1205R2

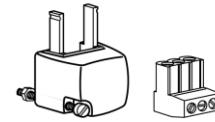

Description

The 599 Series SSA81U Electronic Valve Actuator requires a 24 Vac power supply and receives a floating control signal to control a valve. This actuator is designed to work with 599 Series Zone Valves with a 1/10-inch (2.5 mm) stroke and a threaded valve bonnet that fits the actuator.

Features

- Direct-coupled installation without tools
- Manual override with hex wrench
- Visual position indication

Application

For use in heating and cooling HVAC applications with Siemens 599 Series Zone Valves that need 24 lb (105N) nominal force.

Product Number



Part Number	Description			Prefix Code
SSA81U	24 Vac	Floating	Normally Closed	244

Ordering Information

To order a complete valve plus actuator assembly from the factory, combine the actuator prefix code with the suffix of the valve product number.

To order a single actuator, use the product number (for example, SSA81U).

Warning/Caution Notations

WARNING		Personal injury/loss of life may occur if you do not perform a procedure as specified.
CAUTION		Equipment damage may occur if you do not perform a procedure as specified.

Specifications

Power supply	Operating voltage	24 Vac \pm 20%
	Frequency	50/60 Hz
	Power consumption	0.8 VA
Function	Running time	150 seconds
	Nominal stroke	1/10-inch (2.5 mm)
	Nominal force	24 lb (105N)
Ambient conditions	Ambient temperature	
	Operation	41°F to 122°F (5°C to 50°C)
	Transport and storage	-13°F to 158°F (-25°C to 70°C)
Agency certification		
CE Conformance UL	EMC directive	89/336/EEC
	Low Voltage direction	73/23/EEC
		UL873, cUL Certified to Canadian Standard C22.2 No. 24-93
Miscellaneous	Medium temperature	34°F to 230°F (1°C to 110°C)
	Dimensions Inches (mm)	3.26 H×3.26 W×1.9 D (82×83×48)
	Weight	9 oz (0.25 kg)

Accessory

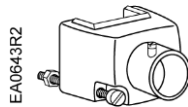

ASY97: Conduit connector, quantity one (1).

Figure 1. Conduit Connector.

Service Kits

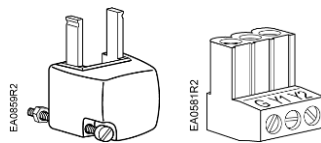

ASY99: Terminal plug and terminal block cover for SSA81U, quantity one each.

Figure 2. Terminal Plug and Block Cover

Operation

The actuators can be driven manually to any position between 0 and 1 with a 3 mm hex wrench. The control signal from the controller; however, will take priority over any manual position.

Mounting and Installation

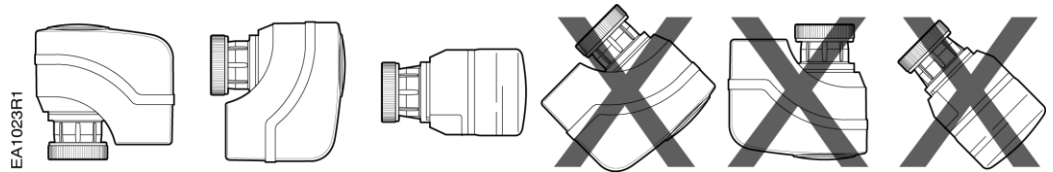

Figure 3. Mounting Position.

Mount the actuator in one of the allowable positions shown in Figure 3.

NOTE: Vertical is the recommended position.

When mounting the actuator in a plenum, the proper cable must be attached to meet local codes.

Allow 8-inches (200 mm) above the actuator and 8-inches (200 mm) behind the cable for service.

Installation Instructions are included with the actuator.

Wiring

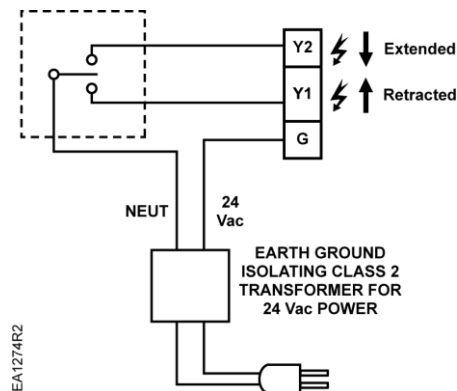

Figure 4. SSA81U Wiring Diagram.

- Do not use autotransformers.
- Use earth-ground isolating, step-down, Class 2, power supplies.
- Determine supply transformer rating by summing total VA of all actuators used.
- Use one transformer to power up to 10 actuators.

Manual Override

The actuators can be driven manually to any position between **0** and **1** with a 3 mm hex key. The actuator will maintain its position until power is provided or restored. A control signal from the controller, however, will take priority over any manual position.

NOTES:

- Do not perform a manual override while the power supply is connected: The actuator will not track properly when the control signal is applied. A short power-off/power-on sequence is recommended to recalibrate the actuator.
- To hold the actuator in the manually set position, the connecting cable must be unplugged.

NOTE:

The **0** and **1** position markings are for reference only and not for stroke measurement.

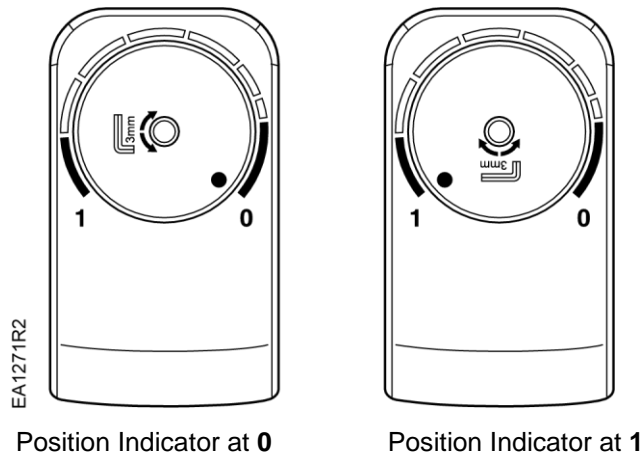

Figure 5. Position Indicator.

Start-Up

Check the wiring and the position indication. See Figure 5 for referred positions **0** and **1** on the position indicator disc.

SSA81U Normally Closed

- When the position indicator disc is at the **0** position the output shaft is extended (two-way valve closed).
- When the position indicator disc rotates to position **1**, the output shaft is retracted (two-way valve open).

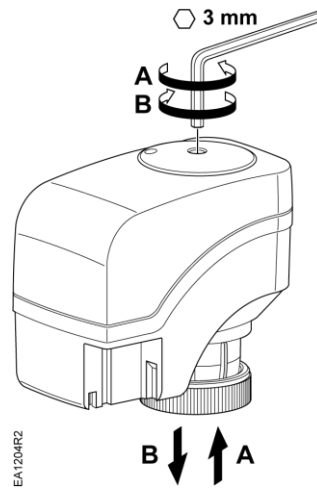

Figure 6. SSA81U Normally Closed.

(A) Turn the hex wrench *counterclockwise* and spindle retracts.

(B) Turn hex wrench *clockwise* and spindle extends.

Troubleshooting

See *Wiring* for proper connections.

If the actuator does not provide full flow or full close off, check that the actuator is properly attached to the valve. If not, turn power off, tighten the bonnet ring on to the valve completely, and power up to recalibrate.

If the actuator becomes inoperative, replace it.

Disposal



The device is considered electrical and electronic equipment for disposal in terms of the applicable European Directive and may not be disposed of as domestic garbage.

- Dispose of the device through channels provided for this purpose.
- Comply with all local and currently applicable laws and regulations.

Dimensions

Inches (Millimeters)

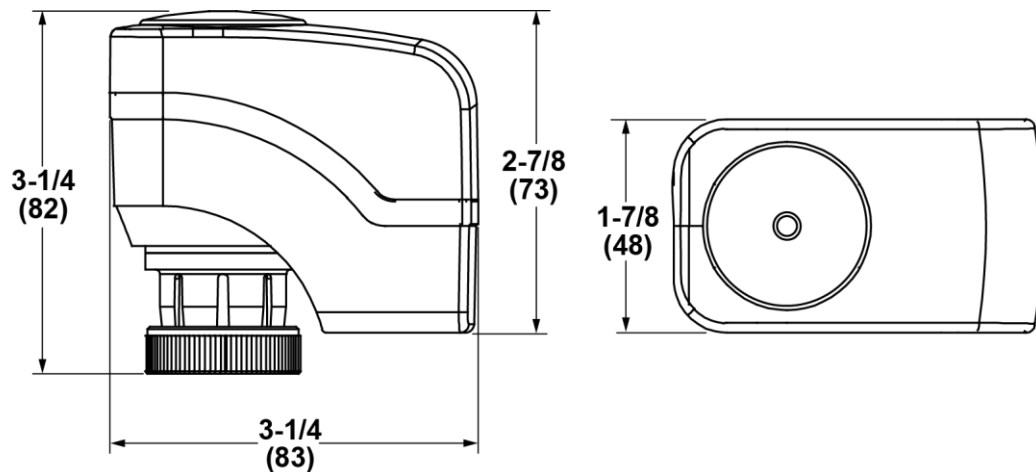

Figure 7. Dimensions of the SSA81U Actuator in Inches (mm).

Service envelope

Minimum access space recommended:

8-inches (200 mm) above the actuator and beside the terminal plug.

Information in this publication is based on current specifications. The company reserves the right to make changes in specifications and models as design improvements are introduced. Other product or company names mentioned herein may be the trademarks of their respective owners.
© 2005 Siemens Building Technologies, Inc.