

## Flowrite™ 599 Series

### High Pressure Close-Off 2-Way Valves, 2-1/2 to 6-Inch, Flanged Iron Body, ANSI Classes 125 & 250

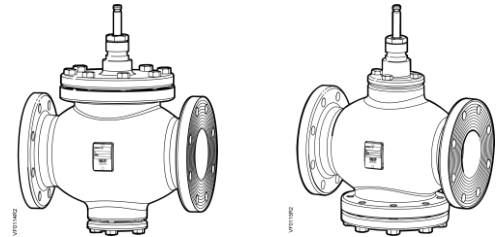

#### Description

The Flowrite 599 Series High Pressure Close-off, two-way flanged valve bodies, are designed to work with either pneumatic or electronic actuators with 3/4-inch (20 mm) or 1-1/2-inch (40 mm) stroke. They are available in both ANSI Class 125 and 250 for normally open or normally closed action.

#### Features

- Valve flange face-to-face dimensions meet ISA 75.03 standards.
- Universal bonnet for direct-coupled actuators
- Equal percentage flow characteristic
- Stainless steel trim
- ANSI Leakage Class IV
- EPDM O-ring packing

#### Application

These Flowrite valves are recommended for chilled or hot water; or 50% water-glycol solutions.

- ANSI 125 and ANSI 250 cast iron body rating.
- Maximum recommended differential pressure for modulating service; 50 psi (345 kPa).

#### Product Numbers

See Tables 1 and 2.

#### Ordering a Valve Plus Actuator Assembly

To order a complete valve plus actuator assembly from the factory, combine the actuator prefix code with the suffix of the valve assembly product number. Valves can be ordered using the numbers in Tables 1 and 2.

**Table 1. Product Numbers for ANSI 125 Valves.**

Action	Flow Rate		Valve Line Size		Stroke		Valve Part Number
	Cv	(Kvs)	Inch	(mm)	Inch	(mm)	
Normally Open	63	(54)	2-1/2	(65)	3/4	(20)	599-06610
	100	(85)	3	(80)	3/4	(20)	599-06611
	160	(137)	4	(100)	1-1/2	(40)	599-06612
	250	(214)	5	(125)	1-1/2	(40)	599-06613
	400	(340)	6	(150)	1-1/2	(40)	599-06614
Normally Closed	63	(54)	2-1/2	(65)	3/4	(20)	599-06615
	100	(85)	3	(80)	3/4	(20)	599-06616
	160	(137)	4	(100)	1-1/2	(40)	599-06617
	250	(214)	5	(125)	1-1/2	(40)	599-06618
	400	(340)	6	(150)	1-1/2	(40)	599-06619

**Table 2. Product Numbers for ANSI 250 Valves.**

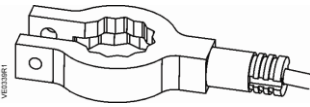

Action	Flow Rate		Valve Line Size		Stroke		Valve Part Number
	Cv	(Kvs)	Inch	(mm)	Inch	(mm)	
Normally Open	63	(54)	2-1/2	(65)	3/4	(20)	599-06620
	100	(85)	3	(80)	3/4	(20)	599-06621
	160	(137)	4	(100)	1-1/2	(40)	599-06622
	250	(214)	5	(125)	1-1/2	(40)	599-06623
	400	(340)	6	(150)	1-1/2	(40)	599-06624
Normally Closed	63	(54)	2-1/2	(65)	3/4	(20)	599-06625
	100	(85)	3	(80)	3/4	(20)	599-06626
	160	(137)	4	(100)	1-1/2	(40)	599-06627
	250	(214)	5	(125)	1-1/2	(40)	599-06628
	400	(340)	6	(150)	1-1/2	(40)	599-06629

<b>Specifications</b>	Valve size	2-1/2 to 6-inch (65 to 150 mm)
	Capacity	See Tables 5 and 6, and Figure 2
	Body style	Flanged
	Seat style	Single seat, metal-to-metal
	Action	Normally Open (NO) Normally Closed (NC)
	Stem travel (stroke)	
	2-1/2 and 3-inch	3/4-inch (20 mm)
4, 5, and 6-inch	1-1/2-inch (40 mm)	
Valve body rating	ANSI Class 125 and 250; see Table 4	
<b>Material</b>	Body	Cast iron ASTM A126 Class B
	Body trim	Stainless steel
	Stem	Stainless steel ASTM A582 Type 303
	Packing	EPDM O-ring
	Controlled medium	Water, 50% water-glycol solutions
	Medium temperature range	20°F to 250°F (-7°C to 120°C)
<b>Operating</b>	Maximum recommended differential pressure for modulating service	50 psi (345 kPa)
	Rangeability	>100:1
	Close-off pressures	See Tables 7 and 8
	Close-off ratings	According to ANSI/FCI 70-2
	Leakage rate	Class IV (0.01% of Cv)
	Flow characteristic	Equal Percentage
<b>Miscellaneous</b>	Canadian Registration Numbers	0H7645.5 0C0838.9
	Mounting location	NEMA 1 (interior only)
	Flange mounting according to ANSI B16.1	See 155-303P25 (TB 248)
	Dimensions	See Tables 14, and Figure 7
	Face-to-face dimensions	ANSI/ISA S75.03
Valve weight	See Table 14	
<b>Accessories</b>		<p><b>ASZ6.6</b> The stem heating element prevents the formation of ice on the stem when the medium temperature drops below 32°F (0°C). It is suited for universal use with valves having a stem or spindle diameter of 10 or 14 mm.</p>
		<p>Operating Voltage      24 Vac/dc ± 20%</p> <p>Power consumption      ≤ 40 VA/30W</p>

**Figure 1. Stem Heating Element.**

St

## Warning/Caution Notations

<b>WARNING:</b>		Personal injury or loss of life may occur if you do not perform a procedure as specified.
<b>CAUTION:</b>		Equipment damage may occur if you do not perform a procedure as specified.

## Service Kits

Packing kit	599-08020
Rebuild/repack kits	See Table 3
Stem retainer kit:	
2-1/2-inch and 3-inch valves	599-10048
4-inch, 5-inch, and 6-inch valves	599-10049

**Table 3. Rebuild/Repack Service Kits.**

ANSI	Action	Valve Body	Valve Size Inch (mm)	Cv	Stroke	Kit No.
ANSI 125	Normally Open	599-06610	2-1/2 (65)	63	3/4 (20)	599-09250
		599-06611	3 (80)	100	3/4 (20)	599-09251
		599-06612	4 (100)	160	1-1/2 (40)	599-09252
		599-06613	5 (125)	250	1-1/2 (40)	599-09253
		599-06614	6 (150)	400	1-1/2 (40)	599-09254
	Normally Closed	599-06615	2-1/2 (65)	63	3/4 (20)	599-09255
		599-06616	3 (80)	100	3/4 (20)	599-09256
		599-06617	4 (100)	160	1-1/2 (40)	599-09257
		599-06618	5 (125)	250	1-1/2 (40)	599-09258
		599-06619	6 (150)	400	1-1/2 (40)	599-09259
ANSI 250	Normally Open	599-06620	2-1/2 (65)	63	3/4 (20)	599-09250
		599-06621	3 (80)	100	3/4 (20)	599-09251
		599-06622	4 (100)	160	1-1/2 (40)	599-09252
		599-06623	5 (125)	250	1-1/2 (40)	599-09253
		599-06624	6 (150)	400	1-1/2 (40)	599-09254
	Normally Closed	599-06625	2-1/2 (65)	63	3/4 (20)	599-09255
		599-06626	3 (80)	100	3/4 (20)	599-09256
		599-06627	4 (100)	160	1-1/2 (40)	599-09257
		599-06628	5 (125)	250	1-1/2 (40)	599-09258
		599-06629	6 (150)	400	1-1/2 (40)	599-09259

**Table 4. Cast Iron Valve Body Ratings.**

Temperature		Pressure psig (kPa)	
°F	°C	ANSI Class 125	ANSI Class 250
-20 to 150	-30 to 66	200 (1387)	500 (3447)
200	93	190 (1310)	460 (3171)
250	121	175 (1206)	415 (2861)
300	149	165 (117)	375 (2585)
400	204	140 (965)	290 (1999)
450	232	125 (861)	250 (1723)

**Table 5. Maximum Water Capacity - U.S. Gallons per Minute.**

Valve Size Inches	Pressure Differential - psi															
	Cv/1	2	3	4	5	6	8	10	15	20	25	30	40	50	60	75
2-1/2	63	89	109	126	141	154	178	199	244	282	315	345	398	445	488	546
3	100	141	173	200	224	245	283	316	387	447	500	548	632	707	775	866
4	160	226	277	320	358	392	453	506	620	716	800	876	1012	1131	1239	1386
5	250	354	433	500	559	612	707	791	968	1118	1250	1369	1581	1768	1936	2165
6	400	566	693	800	894	980	1131	1265	1549	1789	2000	2191	2530	2828	3098	3464

**Table 6. Maximum Water Capacity - Cubic Meters per Hour (m3/hr).**

Valve Size mm	Pressure Differential - kPa														
	1	10	20	30	40	50	60	80	80	Kvs/100	150	200	300	400	500
65	5.4	17.1	24	30	34	38	42	48	54	54	66	76	94	108	121
80	8.5	27	38	47	54	60	66	76	85	85	104	120	147	170	190
100	14	43	61	75	87	97	106	123	137	137	168	194	237	274	306
125	21	68	96	117	135	151	166	191	214	214	262	303	371	428	479
150	34	108	153	187	216	242	265	306	342	342	419	484	592	684	765

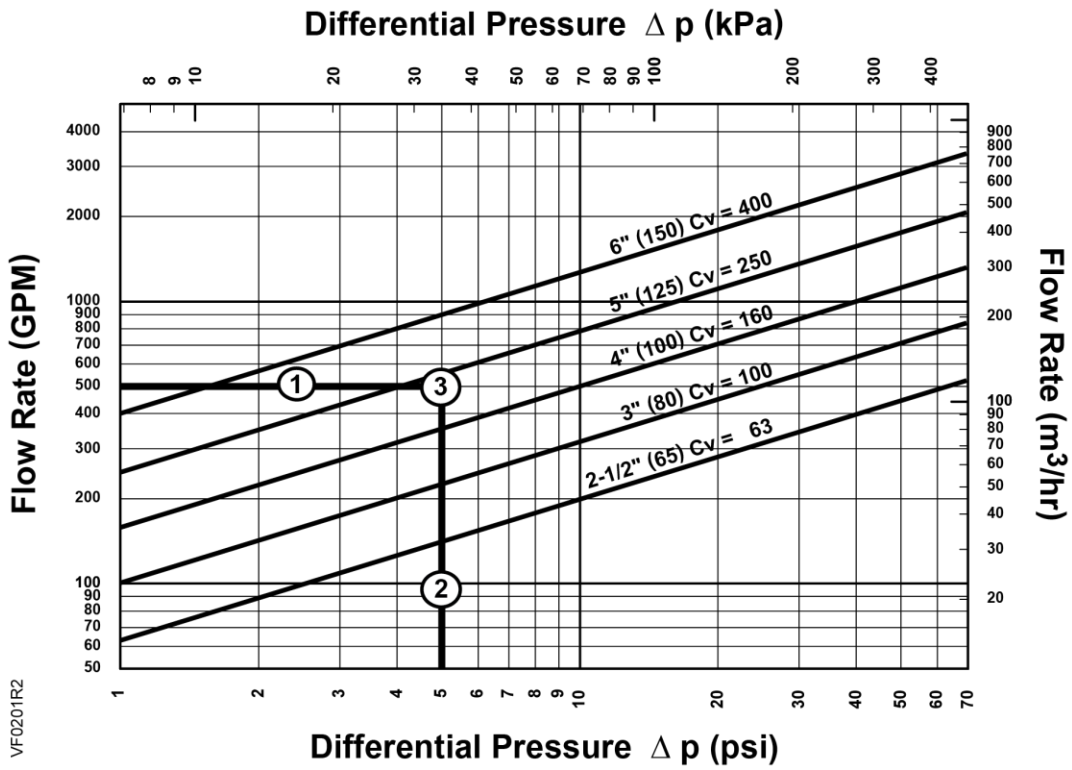

Figure 2. Water Capacity Graph.

Selection Example

Select a valve given:

- ① Required flow = 500 gpm
- ② Desired pressure drop = 5 psi
- ③ Select a 5-inch (125 mm) valve, Cv 250.

**Table 7. Close-off Pressures for Pneumatic Actuators.**

Action	Valve Size, Inch (mm)	Spring Return			
		8- Inch		12-Inch	
		3 to 8 psi (21 to 55 kPa)	10 to 15 psi (69 to 103 kPa)	3 to 8 psi (21 to 55 kPa)	10 to 15 psi (69 to 103 kPa)
				15 psi (103 kPa)	0 psi (0 kPa)
Normally Open	2-1/2 (65)	200 (1378)	—	—	—
	3 (80)	200 (1378)	—	—	—
	4 (100)	—	—	200 (1378)	—
	5 (125)	—	—	200 (1378)	—
	6 (150)	—	—	200 (1378)	—
Normally Closed	2-1/2 (65)	—	200 (1378)	—	—
	3 (80)	—	200 (1378)	—	—
	4 (100)	—	—	—	200 (1378)
	5 (125)	—	—	—	200 (1378)
	6 (150)	—	—	—	200 (1378)

**Table 8. Close-off Pressures for Electronic Actuators**

Action	Valve Size In (mm)	Electro-Hydraulic 24 Vac	
		SKD	SKC
Normally Open	2-1/2 (65)	200 (1378)	—
	3 (80)	200 (1378)	—
	4 (100)	—	200 (1378)
	5 (125)	—	200 (1378)
	6 (150)	—	200 (1378)
Normally Closed	2-1/2 (65)	200 (1378)	—
	3 (80)	200 (1378)	—
	4 (100)	—	200 (1378)
	5 (125)	—	200 (1378)
	6 (150)	—	200 (1378)

---

## Operation

Figure 3 shows the normally open valve in the open or full flow position and the normally closed valve in the closed, or zero flow position. The actuator spring provides the necessary force to hold the stem in the raised or normal position.

In the event of power failure, a spring return actuator returns the valve to its normal position.

Non-spring return actuators will hold the last commanded position. See the Technical Instructions of the various actuators for additional information.

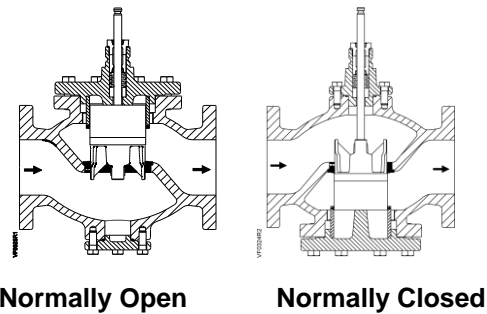

**Figure 3. Operation.**

---

## Sizing

The sizing of a valve is important for correct system operation. An undersized valve will not have sufficient capacity at maximum load. An oversized valve may initiate cycling, and the seat and throttling plug may be damaged because of the restricted opening. Correct sizing of the control valve for actual expected conditions is considered essential for good control.

Some variables which must be determined are:

- The water and 50% water-glycol solutions, are the controlled mediums.
- The pressure differential that will exist across the valve under maximum load demand.
- The maximum capacity the valve must deliver.
- The maximum line pressure differential that the valve actuator must close against.

See Tables 5 through 6, and Figure 2 for valve capacities and sizing selection.

---



## Installation

Install the valve so that the flow follows the direction of the arrow indicated on the valve body identification tag.



### CAUTION:

Install the valve assembly with the actuator above the valve body. The valve and actuator can be installed in any position between:

- Horizontal to the valve; and
- Vertical above the valve.

It is not recommended to install the valve assembly below horizontal or upside down.

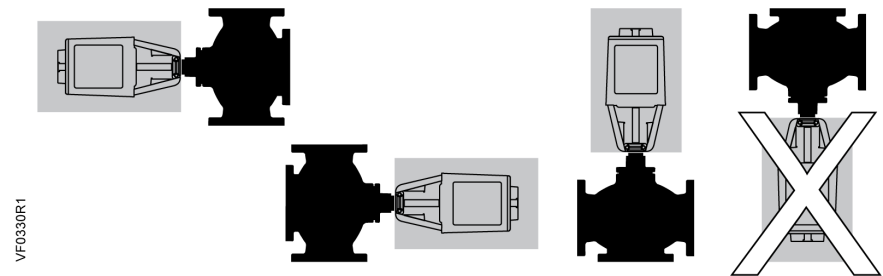

**Figure 4. Recommended Installation Orientations.**

- For flange dimensions and bolt hole information, see *155-303P25 (TB 248)*.
- Allow sufficient space for servicing the valve and actuator. See Table 11 for valve body dimensions. See Figure 7 and Table 10 for dimensions of the service envelope recommended around the actuator.

**NOTE:** Instructions for field mounting an actuator, spring adjustments, wiring diagrams, and start-up are covered in the Technical Instructions and Installation Instructions for each actuator.

## Construction of the Two-Way Valve

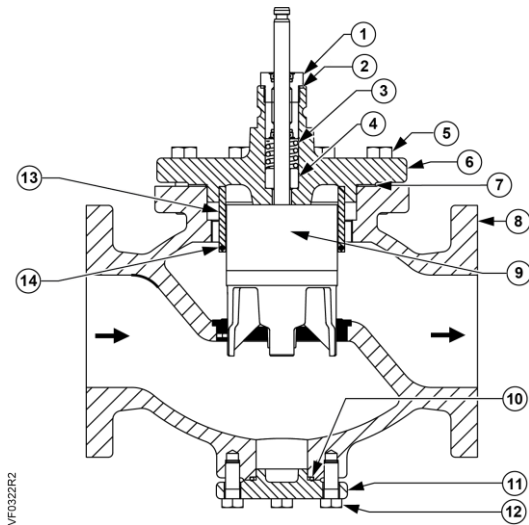

Figure 5. Two-Way Normally Open.

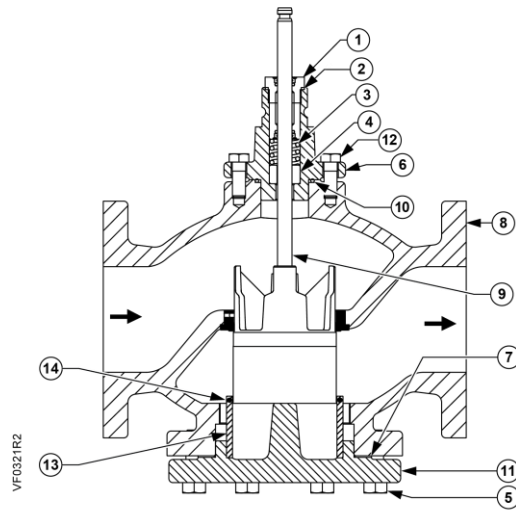

Figure 6. Two-Way Normally Closed.

## Parts List

Table 9. Parts List for Two-Way Flanged Valves.

Item	Part Name	Part No.	Qty	Material
1	Packing Cartridge Assembly	—	1	—
2	Gasket	—	1	Copper
3	Packing Spring	—	1	Stainless Steel
4	Packing Bearing	—	1	Bronze
5	Cap Screw	—	4-8	Plated Steel
6	Bonnet	—	1	Cast Iron
7	Gasket	—	1	—
8	Valve Body	—	1	Cast Iron
9	Stem and Plug Assembly	—	1	Stainless Steel
10	O-ring	—	1	EPDM
11	Cap	—	1	Cast Iron
12	Cap Screw	—	4	Plated Steel
—	Packing Kit	599-08020	—	Items 1, 2, 3 & 4
13	Sleeve	—	1	Cast Iron
14	Sleeve Seal	—	1	—
—	Rebuild/Repack Kit Normally Open	Table 3	—	Items 1, 2, 3, 4, 7, & 9
—	Rebuild/Repack Kit Normally Closed	Table 3	—	Items 1, 2, 3, 4, 7, 9

## Dimensions

**NOTE:** See Table 10 for actuator and recommended service envelope dimensions and Table 11 for actual valve dimensions.

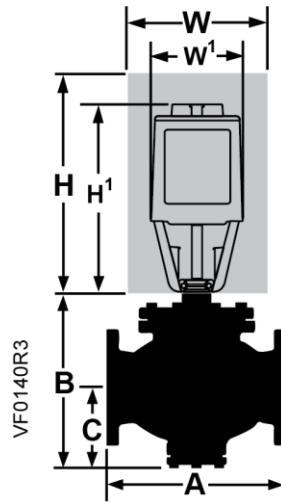

Figure 7 Dimensions.

**Table 10. Dimensions of the Actuator and Recommended Service Envelope.  
 Dimensions in Inches (Millimeters).**

Actuator	Prefix Code	Actual Height of Actuator H1	Service Height H	Actuator Width or Diameter of W1	Service Width W
8" Pneumatic	283	14-1/8 (359)	26 (660)	8-3/4 (222) diameter	21 (450)
12" Pneumatic	287	17-7/8 (454)	30 (762)	15-1/8 (384) diameter	27 (686)
SKD	274	11-13/16 (300)	19-3/4 (430)	6-5/8 (170) width	14-1/2 (360)
SKC with handle closed	294	14-3/4 (375)	22-3/4 (578)	7 (178) Width × 8-15/16 (226) Depth	25 (635)

**Table 11. Valve Dimensions and Weight.**

Action	Valve Size inch (mm)	ANSI Class 125				ANSI Class 250			
		Dimensions Inches (mm)			Weight lbs. (kg)	Dimensions Inches (mm)			Weight lbs. (kg)
		A	B	C		A	B	C	
Normally Open	2-1/2 (65)	11 (276)	11 (281)	4-7/8 (123)	62 (28)	11-1/2 (292)	11 (281)	5 (123)	78 (35)
	3 (80)	11-3/4 (299)	12-1/4 (312)	5-5/16 (135)	79 (35)	12-1/2 (318)	12-1/4 (312)	5-5/16 (135)	102 (46)
	4 (100)	14 (352)	13-9/16 (345)	6-5/16 (160)	129 (58)	14-1/2 (368)	13-5/8 (344.7)	6-5/16 (160)	165 (75)
	5 (125)	15-3/4 (400)	15-3/16 (385)	7 (177)	162 (73)	16-5/8 (422)	15-3/16 (385)	7 (177)	215 (97)
	6 (150)	17-3/4 (451)	16-3/4 (426)	8 (200)	222 (101)	18-5/8 (473)	16-3/4 (426)	8 (200)	312 (142)
Normally Closed	2-1/2 (65)	11 (276)	10-5/8 (269)	5 (125)	60 (27)	11-1/2 (292)	11 (279)	5-3/8 (135)	76 (35)
	3 (80)	11-3/4 (299)	12 (303)	5-5/8 (142)	78 (35)	12-1/2 (318)	12-7/16 (315)	6 (154)	101 (45)
	4 (100)	14 (352)	14 (354)	6-5/8 (168)	128 (58)	14-1/2 (368)	14-3/8 (364)	7 (178)	164 (74)
	5 (125)	15-3/4 (400)	15-1/4 (388)	7-1/2 (185)	160 (72)	16-5/8 (422)	15-3/4 (399)	7-3/4 (196)	214 (97)
	6 (150)	17-3/4 (451)	17-1/16 (433)	8-3/16 (207)	219 (100)	18-5/8 (473)	17-1/2 (444)	8-5/8 (218)	309 (141)

Information in this publication is based on current specifications. The company reserves the right to make changes in specifications and models as design improvements are introduced. Flowrite is a trademark of Siemens Industry, Inc. Product or company names mentioned herein may be the trademarks of their respective owners. © 2019 Siemens Industry, Inc.