

Pressure Independent Control Series



Two-Way Cast Iron Flanged Bodies, ANSI 125 and 250

Description Siemens Pressure Independent Control Valves integrate three functions into a single device: control valve, adjustable flow limiter, and automatic differential pressure regulator. They are available in both ANSI Class 125 and 250.

- Features**
- Control valve with integrated differential pressure regulator and adjustable flow limiter
 - ANSI 125 and ANSI 250 bodies and flanges
 - 2-1/2-, 3-, 4-, 5-, and 6-inch (65, 80, 100, 125, and 150 mm)
 - Field adjustable presetting
 - < ANSI Class IV leakage (0.01%)
 - Pressure test (P/T) points
 - Can be equipped with SAX, SAV, or SQV electromotoric actuators

Product Numbers

Table 1.

Product Number	ANSI Pressure Class	Line Size Inch (mm)	Maximum Flow Range GPM (m ³ /h)	Δp Regulator Operating Range psi (kPa)
599-07330	125	2.5 (65)	21 to 132 (4.8 to 30)	* to 90 (* to 600)
599-07335	250			
599-07331	125	3 (80)	31 to 195 (7 to 44)	* to 90 (* to 600)
599-07336	250			
599-07332	125	4 (100)	64 to 370 (14.4 to 84)	* to 90 (* to 600)
599-07337	250			
599-07333	125	5 (125)	78 to 525 (18 to 119)	* to 90 (* to 600)
599-07338	250			
599-07314	125	6 (150)	115 to 650 (26 to 148)	5 to 90 (35 to 600)
599-07319	125		140 to 860 (32 to 195)	
599-07339	250		106 to 740 (24 to 168)	

* **Note:** See Table 8 for minimum Δp at each given presetting.

Application

- For use in heating, ventilating and air conditioning systems as a control valve
- For closed loop hot or chilled water applications

Caution Notations

CAUTION:		Equipment damage may occur if you do not perform a procedure as specified.
-----------------	---	--

Specifications

Functional Data	Line size	2-1/2-inch (65 mm) to 6-inch (150 mm)	
	Body style	Flanged	
	Pressure class	ANSI 125 and ANSI 250	
	Pressure regulation flow accuracy	± 5%	
	Valve characteristic	Linear	
	Close-off	100 psi (700 kPa)	
	Leakage rate	< ANSI Class IV (0 to 0.01% of nominal maximum flow)	
	Operating direction	Normally open (push to close)	
	Permissible media	Hot water, chilled water, water/glycol solution	
	Medium temperature range	34°F to 250°F (1°C to 121°C)	
Materials	Nominal stroke	2.5- and 3-inch	3/4-inch (20 mm)
		4- and 5-inch	1-1/2-inch (40 mm)
		6-inch	1-11/16-inch (43 mm)
	Valve body	Cast iron	
	Stem, spring, seat	Stainless steel	
General ambient conditions	Plug	Brass (DZR)	
	Regulator	Stainless steel	
	Seals	EPDM (peroxide cured)	
	Temperature		
	Operation	5°F to 131°F (-15°C to 55°C)	
Transport	-22°F to 149°F (-30°C to 65°C)		
Storage	5°F to 122°F (-15°C to 50°C)		
Humidity			
Operation	5 to 95% rh		
Transport	<95% rh		
Storage	5 to 95% rh		

Table 2. Cast Iron Valve Body Ratings.

Temperature		Pressure psig (kPa)			
°F	°C	ANSI Class 125		ANSI Class 250	
-20 to 150	-30 to 66	200	(1387)	500	(3447)
200	93	190	(1310)	460	(3171)
250	121	175	(1206)	415	(2861)
300	149	165	(1137)	375	(2585)
400	204	140	(965)	290	(1999)
450	232	125	(861)	250	(1723)

Table 3. Close-off Pressures for Electronic Actuators.

Valve Size In. (mm)	SAX Non-Spring Return		SAV		SQV	
	psi	kPa	psi	kPa	psi	kPa
2-1/2 (65)	100	700	100	700	100	700
3 (80)	100	700	100	700	100	700
4 (100)	–	–	100	700	100	700
5 (125)	–	–	100	700	100	700
6 (150)	–	–	100	700	100	700

Mechanical Design

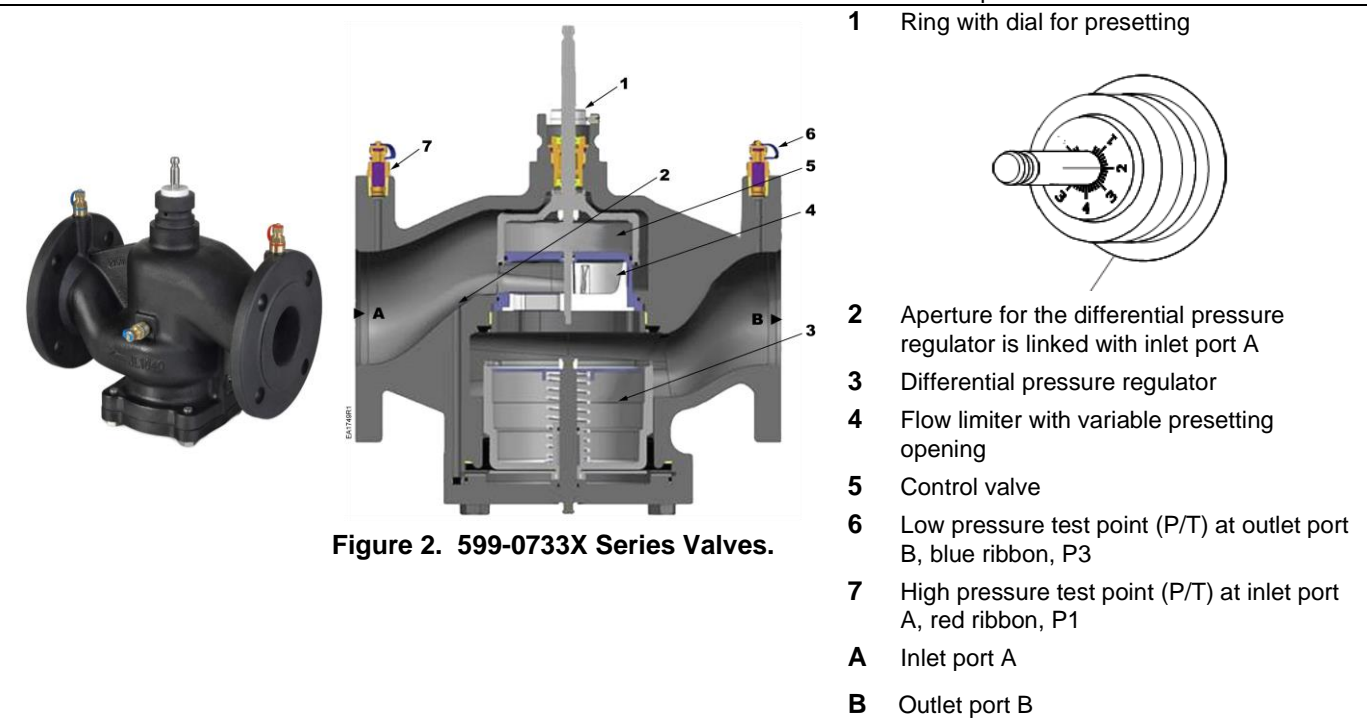
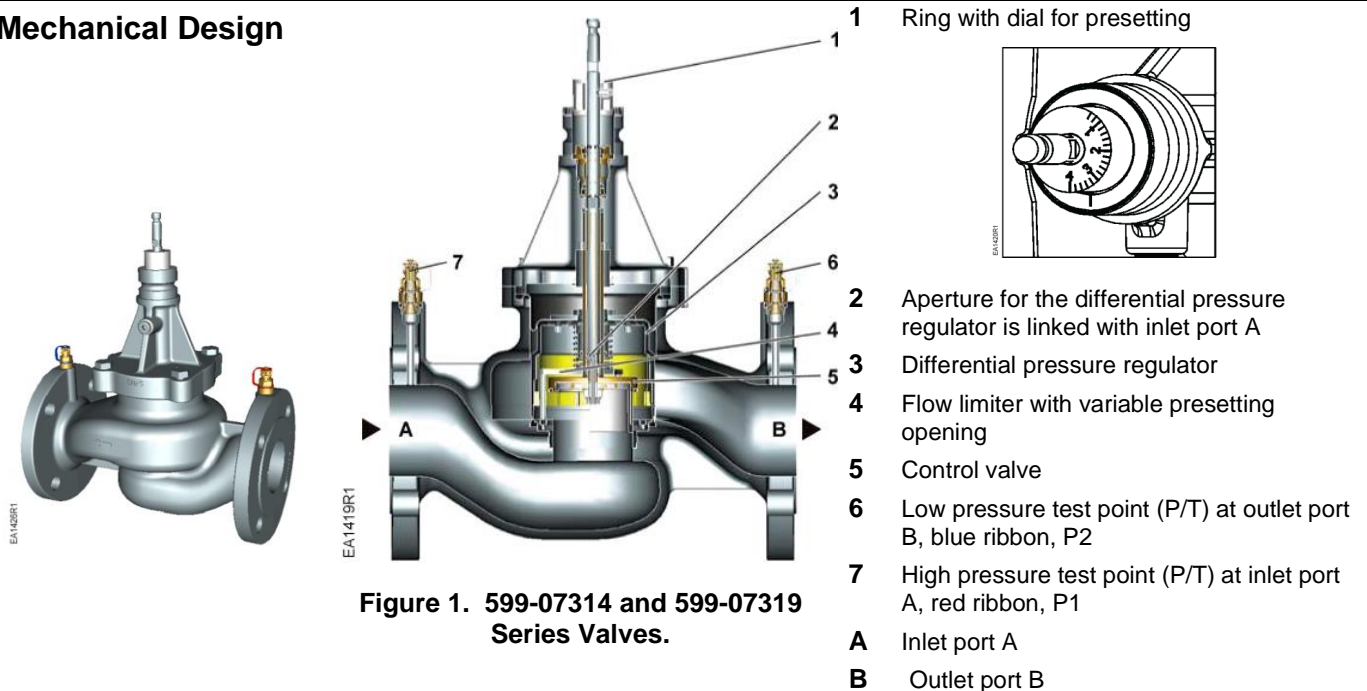

Pressure Test Points

The 599-07314 and 599-07319 Series PICV are equipped with two pressure test points (P1, P2) for measuring the differential pressure across the valve during commissioning or operation. See Figure 3.

The 599-0733X Series PICV are equipped with three pressure test points (P1, P2, P3) for measuring and monitoring the differential pressure across the control valve and across the PICV during commissioning or for analysis during operation. See Figure 4.

Operation

The Pressure Independent Control Valves combine three functions (see Figure 3):

- a control valve (5) for controlling the volumetric flow,
- a field-adjustable flow limiter (4) with a dial (1) for a pre-settable maximum volumetric flow,
- a differential pressure regulator (3) that automatically adjusts to pressure fluctuations in the hydraulic system respectively across the control valve to maintain a constant flow.

The mechanical series-connected differential pressure regulator keeps the differential pressure constant across the control valve, thus maintaining constant flow. The desired maximum volumetric flow can be preset with the field adjustable flow limiter. The building automation system controller (not shown) and the actuator regulate the volumetric flow and consequently the desired temperature in buildings, rooms or zones.

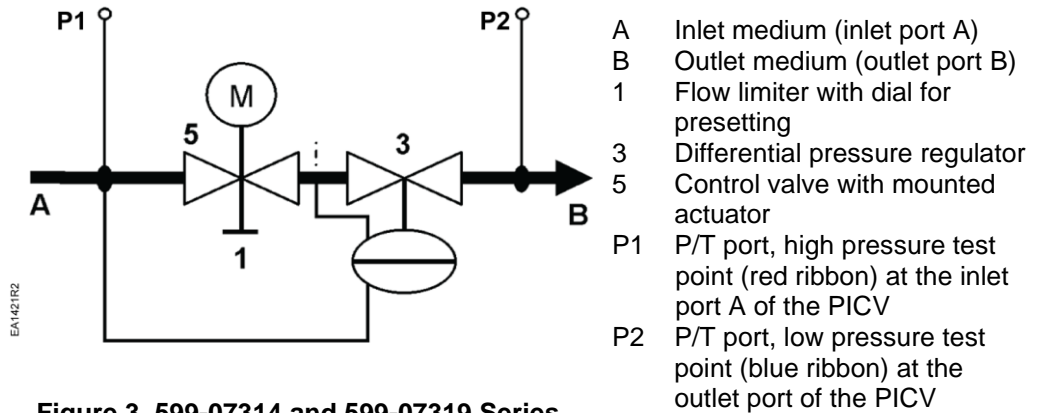

Figure 3. 599-07314 and 599-07319 Series Pressure Independent Control Valve Operation.

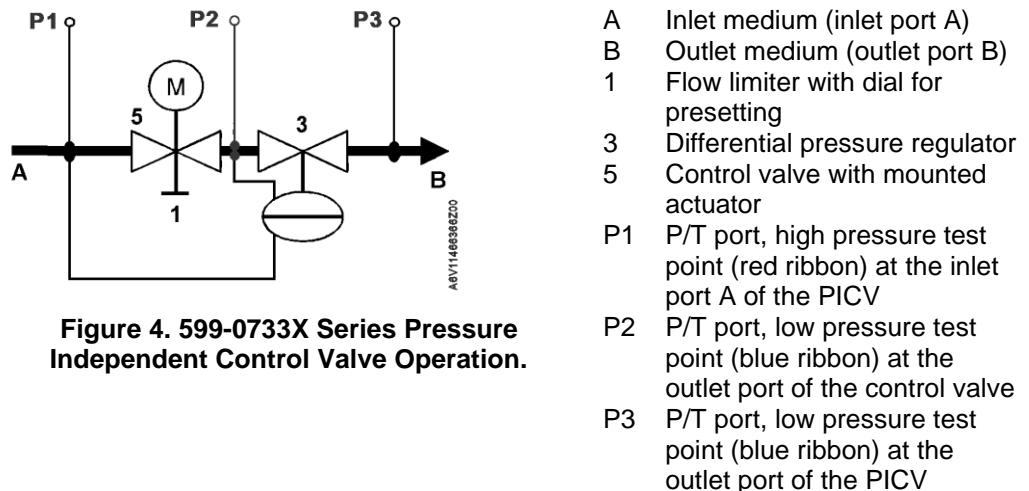

Figure 4. 599-0733X Series Pressure Independent Control Valve Operation.

Medium Flow

The medium entering the Pressure Independent Control Valve (inlet port A) first passes through the variable presetting opening (see Figure 1 and Figure 2) which is connected to the ring with a dial (1) for presetting the desired maximum volumetric flow. The actuator (M in Figure 3 and Figure 4) opens and accurately positions the control valve. Then, the medium flows through control valve (5) with a linear characteristic.

Before leaving the Pressure Independent Control Valve (outlet port B), the medium passes through a built-in mechanical differential pressure regulator (3). This differential pressure regulator is the heart of the Pressure Independent Control Valve and ensures that the selected volumetric flow is maintained across the whole working range and independent of the inlet pressure.

Manual Control

Manual control is only possible with a mounted actuator.

Advantages

The advantages of Pressure Independent Control Valves are:

- Once the flow limiter is set to design flow, the hydronic circuit self balances, even when changes to the system are made, such as additions.
- For any heat demand the Pressure Independent Control Valve with mounted actuator can be set to the desired volumetric flow and will remain constant regardless of pressure fluctuations in the system.

Constant flow regardless of pressure changes in the system leads to a more stable control, less wasted energy and greater comfort.

**Volumetric Flow/
 Dial Presetting**

Tables to determine the dial setting for a desired volumetric flow.

**Table 4. 2-1/2-Inch Valves
 Flow Rates.**

599-0733X Series Valves P/N 599-07330, 599-07335		
Setting	Max. GPM	Max. m ³ /h
4.0	132	30
3.8	125	28.5
3.6	118	26.9
3.4	111	25.2
3.2	104	23.6
3.0	96	21.9
2.8	89	20.2
2.6	81	18.5
2.4	74	16.8
2.2	66	15
2.0	58	13.2
1.8	52	11.9
1.6	47	10.6
1.4	42	9.6
1.2	38	8.6
1.0	32	7.2
0.8	26	5.9
0.6	21	4.8

**Table 5. 3-Inch Valves
 Flow Rates.**

599-0733X Series Valves P/N 599-07331, 599-07336		
Setting	Max. GPM	Max. m ³ /h
4.0	195	44.3
3.8	183	41.5
3.6	171	38.8
3.4	161	36.5
3.2	151	34.2
3.0	138	31.3
2.8	125	28.3
2.6	114	25.9
2.4	103	23.5
2.2	95	21.5
2.0	85	19.4
1.8	76	17.2
1.6	66	15.0
1.4	60	13.6
1.2	54	12.2
1.0	47	10.6
0.8	40	9.0
0.6	31	7.1

Table 6. 4-Inch Valves Flow Rates.

599-0733X Series Valves P/N 599-07332, 599-07337		
Setting	Max GPM	Max m ³ /h
4.0	370	84
3.8	367	83.3
3.6	364	82.6
3.4	350	79.4
3.2	336	76.3
3.0	310	70.4
2.8	279	63.3
2.6	250	56.7
2.4	221	50.2
2.2	199	45.2
2.0	177	40.2
1.8	155	35.3
1.6	134	30.5
1.4	119	27.1
1.2	104	23.7
1.0	89	20.3
0.8	77	17.4
0.6	64	14.4

Table 7. 5-Inch Valves Flow Rates.

P/N 599-0733X Series Valves P/N 599-07333, 599-07338		
Setting	Max. GPM	Max m ³ /h
4.0	525	119
3.8	512	116
3.6	490	111
3.4	452	103
3.2	414	94
3.0	378	86
2.8	354	81
2.6	317	72
2.4	276	63
2.2	253	57
2.0	216	49
1.8	194	44
1.6	168	38
1.4	152	35
1.2	127	29
1.0	109	25
0.8	96	22
0.6	78	18

Table 7. 6-Inch Valves Flow Rates.

Low Flow Valve P/N 599-07314		
Setting	Max. GPM	Max m ³ /h
4.0	650	148
3.8	610	139
3.6	571	130
3.4	533	121
3.2	497	113
3.0	462	105
2.8	429	98
2.6	398	90
2.4	367	83
2.2	338	77
2.0	310	70
1.8	282	64
1.6	255	58
1.4	228	52
1.2	201	46
1.0	173	39
0.8	143	33
0.6	115	26

High Flow Valve P/N 599-07319		
Setting	Max. GPM	Max m ³ /h
4.0	860	195
3.8	796	181
3.6	737	167
3.4	683	155
3.2	632	144
3.0	586	133
2.8	542	123
2.6	501	114
2.4	463	105
2.2	427	97
2.0	392	89
1.8	358	81
1.6	324	74
1.4	291	66
1.2	256	58
1.0	220	50
0.8	182	41
0.6	140	32

599-0733X Series Valves P/N 599-07339		
Setting	Max. GPM	Max m ³ /h
4.0	740	168
3.8	707	161
3.6	665	151
3.4	613	138
3.2	565	128
3.0	537	122
2.8	488	111
2.6	437	99
2.4	386	88
2.2	357	81
2.0	313	71
1.8	267	61
1.6	242	55
1.4	213	48
1.2	178	40
1.0	148	34
0.8	127	29
0.6	106	24

Engineering Notes



CAUTION:

Install the valve so that the flow of the medium matches the direction of the arrow on the valve body. Failure to do so may damage the differential pressure regulator.

Recommendations

- A strainer or dirt trap should be fitted upstream of the valve to enhance reliability and service life.
- Remove dirt, welding beads, and so on from valves and pipes.
- Do not insulate the actuator bracket; air circulation must be ensured.

Mounting Notes

Pressure Independent Control Valves and actuators can be easily assembled on site. Neither special tools nor adjustments, besides the presetting, are required. Prior to mounting the actuator, the required volumetric flow must be set. Each valve is supplied with a bib tag indicating the maximum GPM flow for each setting of the flow limiter.

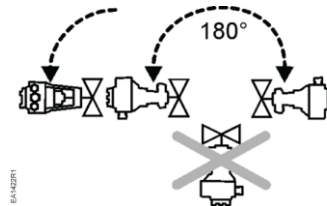

Figure 5. Accepted Mounting Positions.

Installation

- Install the valve so that the flow follows the direction of the arrow indicated on the valve body identification tag.
- For best performance, install the valve assembly with the actuator above the valve body. The valve and actuator can be installed in any position between vertical and horizontal. It is not recommended to install the valve assembly below horizontal or upside down.
- For flange dimensions and bolt hole information, see *Cast Iron Flange Dimensions for 2-1/2 through 6" Valves Technical Bulletin* (155-303P25 [TB 248]).
- Allow sufficient space for servicing the valve and actuator. See Figure 8, Figure 9, and Table 9 for valve body dimensions, and dimensions of the service envelope recommended around the actuator.

NOTE: Instructions for field mounting an actuator, spring adjustments, wiring diagrams, and start-up are covered in the Technical Instructions and Installation Instructions for each actuator.

Presetting

It is recommended to mount the actuator before the presetting.

1. Mount the actuator in the desired orientation and tighten the valve neck coupling.
2. If using an SQV Actuator, slide the anti-rotation device over the stem with the open end guided by the actuator pillar. Do not tighten on valve stem.
3. Mount the valve stem coupling and tighten slightly.
4. Make the presetting as shown below. Do NOT adjust presetting to a dial reading lower than 0.6. Use an open-ended, 8 mm wrench to turn the stem with dial to the desired presetting position.
5. Tighten the stem coupling.
6. Using a 2.5 mm hex wrench, tighten the SQV anti-rotation device onto the valve stem.

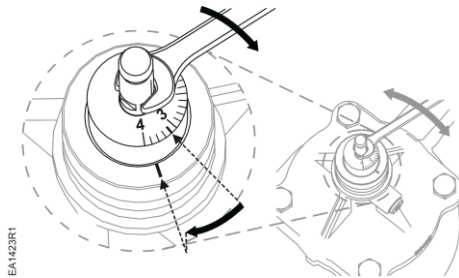

Figure 6. Maximum GPM Flow Presetting Scale for 599-07314 and 599-07319 Series Valves.

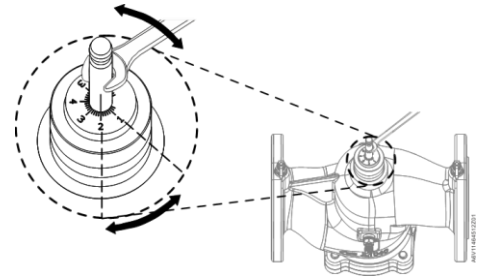

Figure 7. Maximum GPM Flow Presetting Scale for 599-0733X Series Valves.

Table 8. Presettings with Corresponding Nominal Flow and Minimum Δp for 599-0733X Series Valves

Size	Presetting	4	3.8	3.6	3.4	3.2	3	2.8	2.6	2.4	2.2	2	1.8	1.6	1.4	1.2	1	0.8	0.6
2.5"	Nominal Flow (gpm)	132	125	118	111	104	96	89	81	74	66	58	52	47	42	38	32	26	21
	Min Δp (psi)	4.4	4.3	4.2	4.2	4.1	4	4	3.9	3.8	3.8	3.7	3.6	3.5	3.5	3.4	3.3	3.3	3.2
3"	Nominal Flow (gpm)	195	183	171	161	151	138	125	114	103	95	85	76	66	60	54	47	40	31
	Min Δp (psi)	4.9	4.8	4.7	4.6	4.5	4.3	4.2	4.1	4	3.9	3.8	3.6	3.5	3.4	3.3	3.1	3	2.9
4	Nominal Flow (gpm)	370	367	364	350	336	310	279	250	221	199	177	155	134	119	104	89	77	64
	Min Δp (psi)	5.5	5.4	5.2	5.2	5.1	4.9	4.8	4.8	4.6	4.5	4.4	4.4	4.2	4.1	3.9	3.9	3.8	3.6
5	Nominal Flow (gpm)	525	512	490	452	414	378	354	317	276	253	216	194	168	152	127	109	96	78
	Min Δp (psi)	5.5	5.4	5.2	5.0	4.9	4.7	4.6	4.4	4.3	4.1	4.0	3.8	3.7	3.5	3.4	3.2	3.1	2.9
6	Nominal Flow (gpm)	740	707	665	613	565	537	488	437	386	357	313	267	242	213	178	148	127	106
	Min Δp (psi)	5.5	5.4	5.2	5.0	4.9	4.7	4.6	4.4	4.3	4.1	4.0	3.8	3.7	3.5	3.4	3.2	3.1	2.9

**Commissioning
Notes**

- The valves must be commissioned with the actuator correctly fitted.
- The Pressure Independent Control Valves must be open when flushing or pressure testing the system. Strong pressure impacts can damage closed Pressure Independent Control Valves.
- Differential pressure Δp_{\max} across the valve's control path is not allowed to exceed 90 psi.

**Maintenance
Notes**

The Pressure Independent Control Valves are maintenance-free.

When performing service work on the valve or actuator:

- Switch off the pump and disconnect the power supply.
- Close the shut-off valves in the piping network.
- Fully reduce pressure in the piping network and allow the pipes to cool down completely.

Remove the electrical connections only if necessary.

Stem Seals

The stem seals cannot be exchanged. In case of leakage, replace the entire valve.

Warranty

Application-related technical data are guaranteed only when the valves are used in connection with the Siemens actuators.

Siemens warranty is void, if used with non-Siemens actuators.

Dimensions

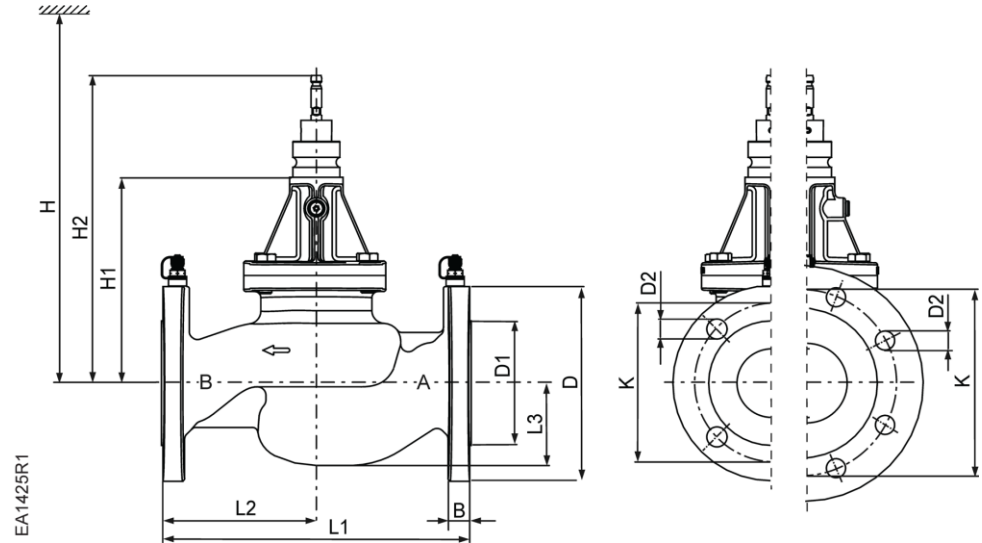

Figure 8. 599-07314 and 599-07319 Series Valves.

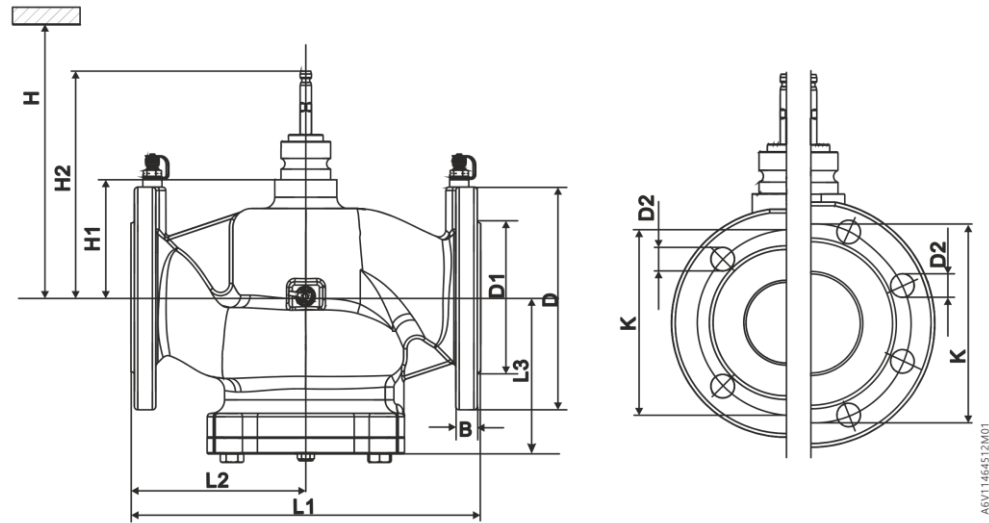

Figure 9. 599-0733X Series Valves.

Table 9. Dimensions and Weights.

Product Number	Valve Size Inches (mm)	B	Ø D	Ø D1	Ø D2	L1	L2	L3	Ø K	H1	H2	H			Weight Pounds (kg)
												SAX	SAV	SQV	
599-07330	2.5 (65)	0.69 (17.5)	7.01 (178)	N/A	0.75 (19)	10.87 (276)	5.43 (138)	5.1 (129.5)	5.50 (140)	4.09 (104)	7.89 (200.5)	21.5 (546)	—	23.35 (593)	42 (19)
599-07335		0.94 (24)	7.48 (190)	4.96 (126)	0.88 (22.4)	11.50 (292)	5.75 (146)	5.1 (129.5)	5.88 (149.4)	4.09 (104)	7.89 (200.5)	21.5 (546)	—	23.35 (593)	62 (28.1)
599-07331	3 (80)	0.75 (19)	7.50 (191)	N/A	0.75 (19)	11.75 (298)	5.87 (149)	5.77 (146.5)	6.00 (152)	4.09 (104)	7.89 (200.5)	21.5 (546)	—	23.35 (593)	59 (26.8)
599-07336		1.06 (27)	8.25 (210)	5.74 (145.8)	0.88 (22.4)	12.5 (318)	6.26 (159)	5.77 (146.5)	6.62 (168)	4.09 (104)	7.89 (200.5)	21.5 (546)	—	23.35 (593)	80 (36.3)
599-07332	4 (100)	0.98 (25)	9.00 (228.6)	N/A	0.75 (19)	13.86 (352)	6.93 (176)	7.26 (184.5)	7.5 (190.5)	6.65 (169)	11.24 (285.5)	—	24.96 (634)	25.91 (658)	82 (37.2)
599-07337		1.04 (26.5)	10 (254)	6.94 (176.3)	0.88 (22.4)	14.40 (365.8)	7.2 (183)	7.26 (184.5)	7.88 (200.2)	6.65 (169)	11.24 (285.5)	—	24.96 (634)	25.91 (658)	146 (66.2)
599-07333	5 (125)	0.98 (25)	10 (254)	N/A	0.88 (22.4)	15.75 (400)	7.87 (200)	7.99 (203)	8.50 (216)	8.01 (203.5)	12.70 (322.5)	—	31.14 (791)	32.09 (815)	182 (82.7)
599-07338	5 (250)	1.44 (36.6)	10.98 (279)	8.31 (211.1)	0.88 (22.4)	16.62 (422.2)	8.31 (211.1)	7.99 (203)	9.25 (235)	8.01 (203.5)	12.70 (322.5)	—	32.01 (813)	32.95 (837)	229 (104)
599-07314 599-07319	6 (150)	1.05 (26.70)	11 (279.4)	N/A	0.88 (22.4)	17.76 (451)	9.17 (233)	6.15 (156.3)	9.50 (241.3)	15.79 (401)	17.48 (444)	—	36.06 (916)	37.01 (940)	235 (106)
599-07339	6 (250)	1.50 (38.1)	12.52 (318)	9.69 (246)	0.88 (22.4)	18.62 (473)	9.31 (236.5)	9.17 (233)	10.63 (270)	7.76 (197)	12.56 (319)	—	32.01 (813)	32.95 (837)	322 (146)

ØD1 = Raised area of flange

H = Total actuator height plus minimum distance to the wall or the ceiling for mounting, connection, operation, maintenance, etc.

H1 = Dimension from the pipe center to install the actuator (upper edge)

H2 = Valve in the «Open» position means that the valve stem is fully extended

Information in this publication is based on current specifications. The company reserves the right to make changes in specifications and models as design improvements are introduced. Product or company names mentioned herein may be the trademarks of their respective owners. © 2022-2024 Siemens Industry, Inc.