

599 Series 6-Way Ball Valves



Description



The 599 Series 6-way ball valves couple with the Siemens GDE161.1P OpenAir™ modulating actuator to provide single valve and actuator changeover and control of hot and chilled water for heated/chilled beam applications or any four-pipe system.

Features

- Control two media sources (hot and chilled water) to a single coil with one valve and actuator.
- 232 psi (16 bar) pressure rating.
- Large C_v range (0.3 to 4.7 C_v) for each media source.
- 1/2-, 3/4-, and 1-inch line size connections.
- 58 psi (4 bar) close-off.
- 0% leakage prevents mixing of hot and chilled water.
- Chrome-plated brass balls and stainless steel stem.
- Blow-out proof stem.
- Actuator and mounting bracket can easily be rotated (90-degree increments).
- Operating handle for manual operation.
- Built-in pressure compensation function.

Application

The 6-way ball valves changeover and control hot and chilled water (both sources similarly treated) in heated/chilled beams and any other four-pipe system utilizing the same coil to heat and cool.

WARNING:		Personal injury or loss of life may occur if you do not perform a procedure as specified.
CAUTION:		Equipment damage may occur if you do not perform a procedure as specified.

Product Numbers	See Table 1 through Table 3.	
Accessories/Kits	ASK77.3	ISO Flange Mounting Kit for GDE Actuators on 6-way ball valves
	599-10660	1/2" union fittings with NPT female tailpieces and gaskets (6 pack)
	599-10662	3/4" union fittings with NPT female tailpieces and gaskets (6 pack)
	599-10663	1" union fittings with NPT female tailpieces and gaskets (6 pack)
Specifications	Body	Hot-pressed brass CW617N
	Balls	Chrome-plated brass
Material	Ball seals	Low friction PTFE
	C _v inserts	Stainless steel
	End connections	1/2-, 3/4-, and 1-inch NPT union, female
	Stem	Stainless steel
	Stem seals	EPDM O-rings
Operating	Valve body rating	232 psi (16 bar)
	Media temperature	41°F to 194°F (5°C to 90°C)
	Controlled medium	Water, water-glycol solutions up to 50%
	Flow characteristic	Linear
	Angle of rotation	0° to 90°
	Close-off rating	58 psi (4 bar)
	Leakage	0%
	Maximum recommended differential pressure	29 psi (2 bar)
Miscellaneous	Mounting location	NEMA 1 (interior only)
	Dimensions, service envelope, weight	See Figure 8 and Figure 9.
	Agency Certification (for actuator)	UL Meets UL 873 cUL Certified to Canadian Standard C22.2 No. 24.93

Ordering a Valve/Actuator Assembly

Use the product numbers in Table 1 through Table 3 to order a valve or a valve and actuator assembly. The valve product number consists of a 599 valve prefix code, a hyphen, a 5-digit valve body code, a hyphen, the source A C_v value, a hyphen, and the source B C_v value.

Valve Product Number Example:

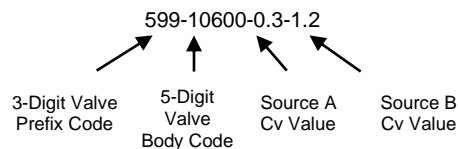

The valve and actuator assembly product number consists of the 171C actuator prefix code, a hyphen, a 5-digit valve body code, a hyphen, the source A C_v value, a hyphen, followed by the source B C_v value.

Valve and Actuator Product Number Example:

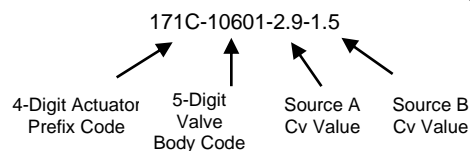

Table 1. 1/2-Inch Valve and Actuator Assemblies.

Valve Body	Line Size, Inch (mm)	Source A C _v Value	Source B C _v Value	Non-Spring Return, 0 to 10V GDE161.1P
				
				Actuator Prefix Code 171C
599-10600-0.3-0.3	1/2 (15)	0.3	0.3	171C-10600-0.3-0.3
599-10600-0.3-0.5		0.3	0.5	171C-10600-0.3-0.5
599-10600-0.3-0.8		0.3	0.8	171C-10600-0.3-0.8
599-10600-0.3-1.2		0.3	1.2	171C-10600-0.3-1.2
599-10600-0.3-1.5		0.3	1.5	171C-10600-0.3-1.5
599-10600-0.3-1.9		0.3	1.9	171C-10600-0.3-1.9
599-10600-0.5-0.3		0.5	0.3	171C-10600-0.5-0.3
599-10600-0.5-0.5		0.5	0.5	171C-10600-0.5-0.5
599-10600-0.5-0.8		0.5	0.8	171C-10600-0.5-0.8
599-10600-0.5-1.2		0.5	1.2	171C-10600-0.5-1.2
599-10600-0.5-1.5		0.5	1.5	171C-10600-0.5-1.5
599-10600-0.5-1.9		0.5	1.9	171C-10600-0.5-1.9
599-10600-0.8-0.3		0.8	0.3	171C-10600-0.8-0.3
599-10600-0.8-0.5		0.8	0.5	171C-10600-0.8-0.5
599-10600-0.8-0.8		0.8	0.8	171C-10600-0.8-0.8
599-10600-0.8-1.2		0.8	1.2	171C-10600-0.8-1.2
599-10600-0.8-1.5		0.8	1.5	171C-10600-0.8-1.5
599-10600-0.8-1.9		0.8	1.9	171C-10600-0.8-1.9
599-10600-1.2-0.3		1.2	0.3	171C-10600-1.2-0.3
599-10600-1.2-0.5		1.2	0.5	171C-10600-1.2-0.5
599-10600-1.2-0.8		1.2	0.8	171C-10600-1.2-0.8
599-10600-1.2-1.2		1.2	1.2	171C-10600-1.2-1.2
599-10600-1.2-1.5		1.2	1.5	171C-10600-1.2-1.5
599-10600-1.2-1.9		1.2	1.9	171C-10600-1.2-1.9
599-10600-1.5-0.3		1.5	0.3	171C-10600-1.5-0.3
599-10600-1.5-0.5		1.5	0.5	171C-10600-1.5-0.5
599-10600-1.5-0.8		1.5	0.8	171C-10600-1.5-0.8
599-10600-1.5-1.2		1.5	1.2	171C-10600-1.5-1.2
599-10600-1.5-1.5		1.5	1.5	171C-10600-1.5-1.5
599-10600-1.5-1.9		1.5	1.9	171C-10600-1.5-1.9
599-10600-1.9-0.3		1.9	0.3	171C-10600-1.9-0.3
599-10600-1.9-0.5		1.9	0.5	171C-10600-1.9-0.5
599-10600-1.9-0.8		1.9	0.8	171C-10600-1.9-0.8
599-10600-1.9-1.2	1.9	1.2	171C-10600-1.9-1.2	
599-10600-1.9-1.5	1.9	1.5	171C-10600-1.9-1.5	
599-10600-1.9-1.9	1.9	1.9	171C-10600-1.9-1.9	

Table 2. 3/4-Inch Valve and Actuator Assemblies.

Valve Body	Line Size, Inch (mm)	Source A Cv Value	Source B Cv Value	Non-Spring Return, 0 to 10V GDE161.1P
				 Actuator Prefix Code 171C
599-10601-0.8-0.8	3/4 (20)	0.8	0.8	171C-10601-0.8-0.8
599-10601-0.8-1.2		0.8	1.2	171C-10601-0.8-1.2
599-10601-0.8-1.5		0.8	1.5	171C-10601-0.8-1.5
599-10601-0.8-1.9		0.8	1.9	171C-10601-0.8-1.9
599-10601-0.8-2.9		0.8	2.9	171C-10601-0.8-2.9
599-10601-0.8-4.0		0.8	4.0	171C-10601-0.8-4.0
599-10601-0.8-4.7		0.8	4.7	171C-10601-0.8-4.7
599-10601-1.2-0.8		1.2	0.8	171C-10601-1.2-0.8
599-10601-1.2-1.2		1.2	1.2	171C-10601-1.2-1.2
599-10601-1.2-1.5		1.2	1.5	171C-10601-1.2-1.5
599-10601-1.2-1.9		1.2	1.9	171C-10601-1.2-1.9
599-10601-1.2-2.9		1.2	2.9	171C-10601-1.2-2.9
599-10601-1.2-4.0		1.2	4.0	171C-10601-1.2-4.0
599-10601-1.2-4.7		1.2	4.7	171C-10601-1.2-4.7
599-10601-1.5-0.8		1.5	0.8	171C-10601-1.5-0.8
599-10601-1.5-1.2		1.5	1.2	171C-10601-1.5-1.2
599-10601-1.5-1.5		1.5	1.5	171C-10601-1.5-1.5
599-10601-1.5-1.9		1.5	1.9	171C-10601-1.5-1.9
599-10601-1.5-2.9		1.5	2.9	171C-10601-1.5-2.9
599-10601-1.5-4.0		1.5	4.0	171C-10601-1.5-4.0
599-10601-1.5-4.7		1.5	4.7	171C-10601-1.5-4.7
599-10601-1.9-0.8		1.9	0.8	171C-10601-1.9-0.8
599-10601-1.9-1.2		1.9	1.2	171C-10601-1.9-1.2
599-10601-1.9-1.5		1.9	1.5	171C-10601-1.9-1.5
599-10601-1.9-1.9		1.9	1.9	171C-10601-1.9-1.9
599-10601-1.9-2.9		1.9	2.9	171C-10601-1.9-2.9
599-10601-1.9-4.0		1.9	4.0	171C-10601-1.9-4.0
599-10601-1.9-4.7		1.9	4.7	171C-10601-1.9-4.7
599-10601-2.9-0.8		2.9	0.8	171C-10601-2.9-0.8
599-10601-2.9-1.2		2.9	1.2	171C-10601-2.9-1.2
599-10601-2.9-1.5		2.9	1.5	171C-10601-2.9-1.5
599-10601-2.9-1.9		2.9	1.9	171C-10601-2.9-1.9
599-10601-2.9-2.9		2.9	2.9	171C-10601-2.9-2.9
599-10601-2.9-4.0		2.9	4.0	171C-10601-2.9-4.0
599-10601-2.9-4.7		2.9	4.7	171C-10601-2.9-4.7
599-10601-4.0-0.8		4.0	0.8	171C-10601-4.0-0.8
599-10601-4.0-1.2		4.0	1.2	171C-10601-4.0-1.2
599-10601-4.0-1.5		4.0	1.5	171C-10601-4.0-1.5
599-10601-4.0-1.9		4.0	1.9	171C-10601-4.0-1.9
599-10601-4.0-2.9		4.0	2.9	171C-10601-4.0-2.9
599-10601-4.0-4.0		4.0	4.0	171C-10601-4.0-4.0
599-10601-4.0-4.7		4.0	4.7	171C-10601-4.0-4.7
599-10601-4.7-0.8	4.7	0.8	171C-10601-4.7-0.8	
599-10601-4.7-1.2	4.7	1.2	171C-10601-4.7-1.2	
599-10601-4.7-1.5	4.7	1.5	171C-10601-4.7-1.5	
599-10601-4.7-1.9	4.7	1.9	171C-10601-4.7-1.9	
599-10601-4.7-2.9	4.7	2.9	171C-10601-4.7-2.9	
599-10601-4.7-4.0	4.7	4.0	171C-10601-4.7-4.0	
599-10601-4.7-4.7	4.7	4.7	171C-10601-4.7-4.7	

Table 3. 1-Inch Valve and Actuator Assemblies.

Valve Body	Line Size, Inch (mm)	Source A Cv Value	Source B Cv Value	Non-Spring Return, 0 to 10V GDE161.1P
				Actuator Prefix Code 171C
599-10602-1.9-1.9	1 (25)	1.9	1.9	171C-10602-1.9-1.9
599-10602-1.9-2.9		1.9	2.9	171C-10602-1.9-2.9
599-10602-1.9-4.0		1.9	4.0	171C-10602-1.9-4.0
599-10602-1.9-4.7		1.9	4.7	171C-10602-1.9-4.7
599-10602-2.9-1.9		2.9	1.9	171C-10602-2.9-1.9
599-10602-2.9-2.9		2.9	2.9	171C-10602-2.9-2.9
599-10602-2.9-4.0		2.9	4.0	171C-10602-2.9-4.0
599-10602-2.9-4.7		2.9	4.7	171C-10602-2.9-4.7
599-10602-4.0-1.9		4.0	1.9	171C-10602-4.0-1.9
599-10602-4.0-2.9		4.0	2.9	171C-10602-4.0-2.9
599-10602-4.0-4.0		4.0	4.0	171C-10602-4.0-4.0
599-10602-4.0-4.7		4.0	4.7	171C-10602-4.0-4.7
599-10602-4.7-1.9		4.7	1.9	171C-10602-4.7-1.9
599-10602-4.7-2.9		4.7	2.9	171C-10602-4.7-2.9
599-10602-4.7-4.0		4.7	4.0	171C-10602-4.7-4.0
599-10602-4.7-4.7		4.7	4.7	171C-10602-4.7-4.7

Mounting and Installation

The 6-way ball valve is delivered in the closed position. When shipped as a valve/actuator assembly, the actuator is in the 45° position.

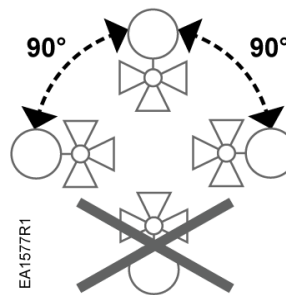

Figure 1. Acceptable Mounting Positions.

Operation

The 6-way ball valve enables control between two sources (A and B) through positions 0° and 90° and is closed at 45°. Both sources supply the same coil (C). See Figure 2 and Figure 3.

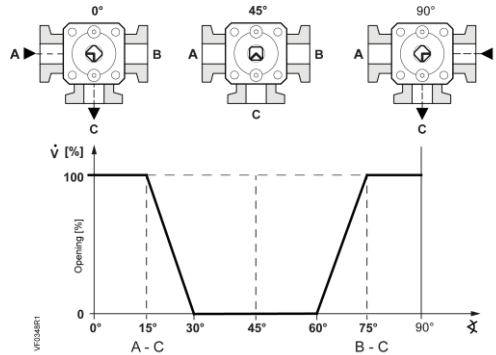

Figure 2. 6-way Ball Valve Characteristic Curve, 1/2-Inch Valve.

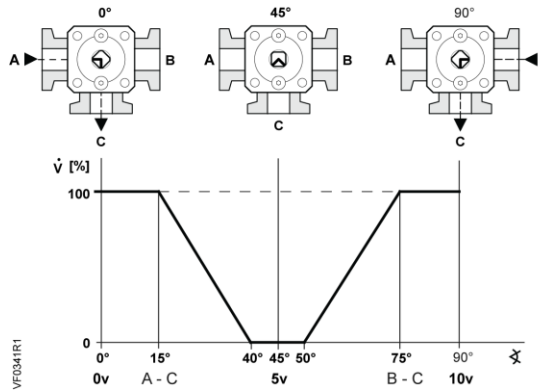

Figure 3. 6-way Ball Valve Characteristic Curve, 3/4- and 1-inch Valves.

The 6-way ball valve is combined with the GDE161.1P modulating fail-in-place actuator. The market standard operation is shown in Figure 2 and Figure 3. A control signal of 0V provides full flow from Source A, 5V is both Source A and Source B closed, and 10V provides full flow from Source B. Both Sources A and B have a linear flow characteristic. The control range for modulating the flow of Source A is with a control signal between 0V and 3.3V for the 1/2-inch valves and between 0V and 4.5V for the 3/4-inch and 1-inch valves. The control range for modulating the flow of Source B is with a control signal between 6.6V and 10V for the 1/2-inch valves and between 5.5V and 10V for the 3/4-inch and 1-inch valves.



CAUTION:

For the actuator to operate according to the market standard described above, the DIP switches must be set as shown in Figure 4. The left DIP switch is set to the off (down) position, while the middle and right DIP switches are set to the on (up) position. These are the settings when the 171C 6-way valve/actuator assemblies are shipped from the factory. If the GDE161.1P actuator is purchased separately, the default DIP switch settings are all in the off (down) position, and must be set as shown in Figure 4 when used with the 6-way ball valves.

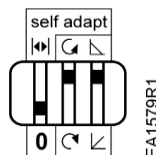

Figure 4. GDE161.1P DIP Switch Settings for Proper 6-Way Ball Valve Operation.

**Operation,
 Continued**

The Siemens 6-way Ball Valve has an internal pressure equalization function that ensures the safe operation of heated and chilled ceilings in a closed valve state (45° position). Changes to media temperature in the heated and chilled ceiling can result in over or under pressure in a closed state and may even damage part of the heated and chilled ceiling. The safety function only acts in the closed valve position (45°). The heating and cooling circuits are safely separated while operating.

Flow Direction

Ensure that the valve is installed with both media sources piped with proper flow direction. Flow direction is indicated on the bib tag that ships with each 6-way ball valve and is shown below. See Figure 5.

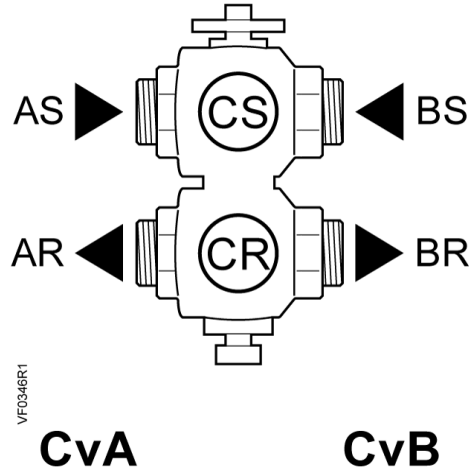

AS = Supply from Source A CS = Supply to Coil BS = Supply from Source B
 AR = Return to Source A CR = Return from Coil BR = Return to Source B
 C_{vA} = C_v for Source A C_{vB} = C_v for Source B

Figure 5. Flow Direction.

To illustrate the information in the *Operation* and *Flow Direction* sections above, Figure 6 shows the Source A and Source B flow curves versus the actuator rotation and control signal voltage for part numbers 599-10601-1.5-2.9 and 171C-10601-1.5-2.9. In this example, the C_v of Source A (C_{vA}) is 1.5, and the C_v of Source B (C_{vB}) is 2.9.

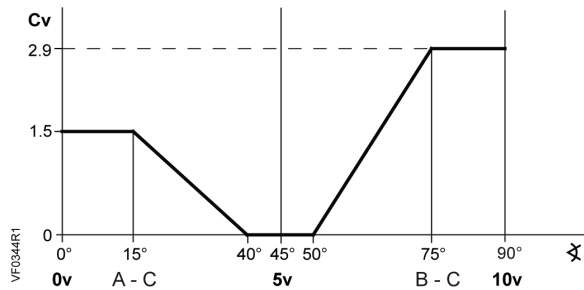

Figure 6. Example Control Characteristic Curve for 599-10601-1.5-2.9 and 171C-10601-1.5-2.9.

Application Example

Heating or cooling sources can be applied to either the Source A or Source B connection, but ensure that the correct C_v values correspond to the sources being connected to each side:

Stem rotates counterclockwise \Rightarrow Source B (cooling sequence) opens or Source A (heating sequence) closes.

Stem rotates clockwise \Rightarrow Source A (heating sequence) opens or Source B (cooling sequence) closes.

The following example application describes the flow direction in a heated and chilled ceiling:

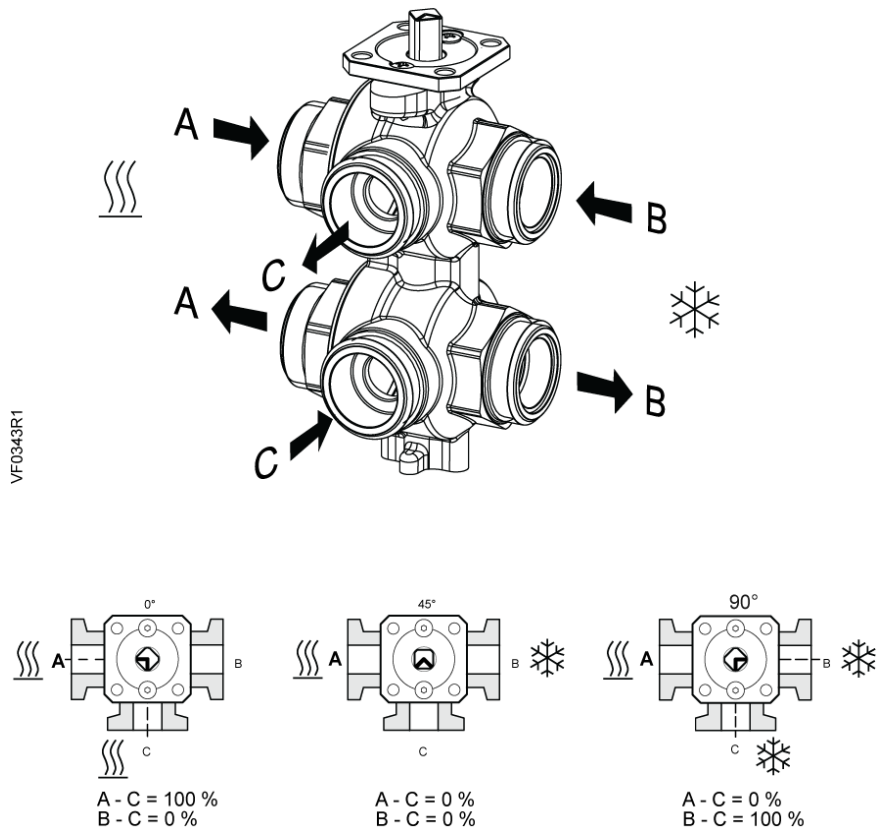

Figure 7. Source A (Heating) and Source B (Cooling) Application Example.

Service

The 6-way ball valve and actuator are maintenance-free.

Dimensions

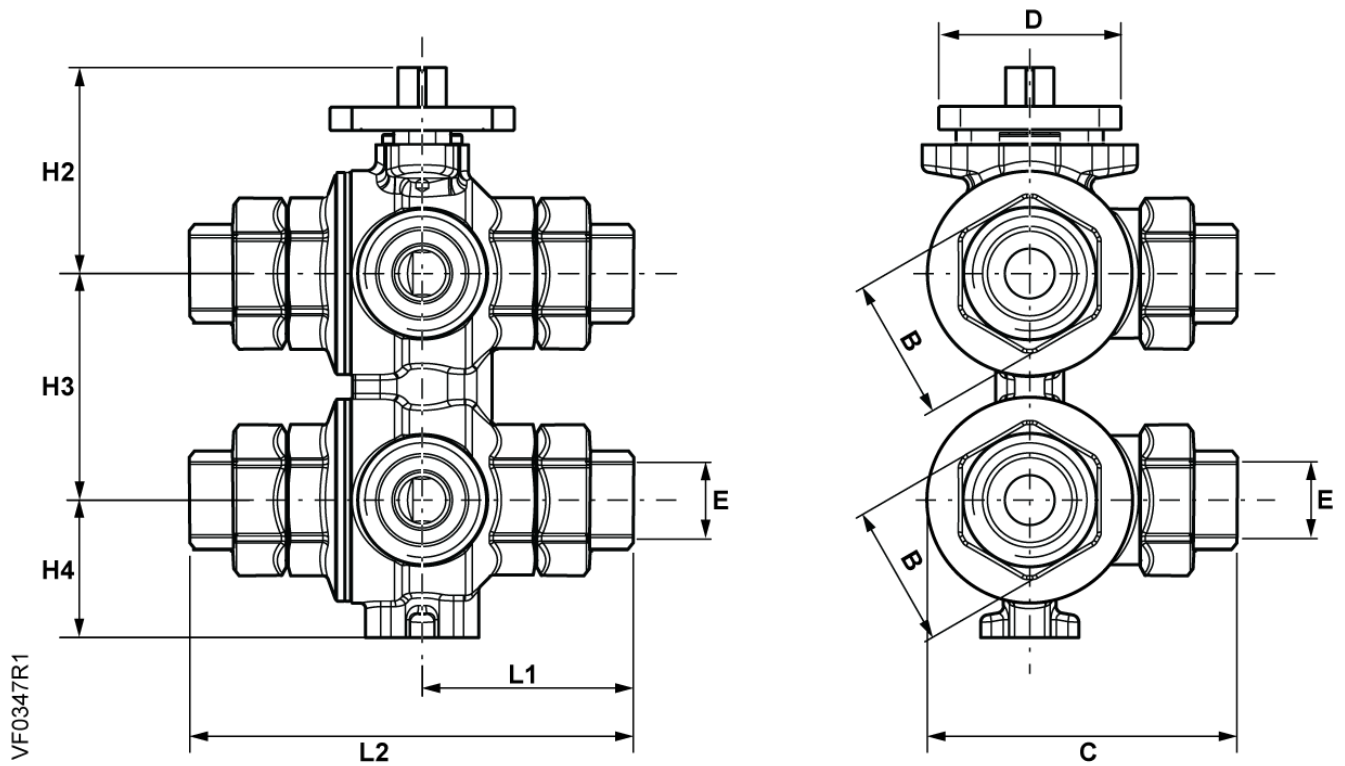

Figure 8. 6-Way Ball Valve Dimensions in Inches (Millimeters).

Part Number	Line Size	B	C	D	E	L1	L2	H2	H3	H4	Weight lb (kg)
599-10600...	1/2 (15)	1.00 (25)	3.44 (87)	1.65 (42)	0.50 (15)	2.81 (71)	5.63 (143)	1.88 (48)	1.75 (45)	1.13 (29)	5.2 (2.36)
599-10601...	3/4 (20)	1.50 (38)	4.25 (108)		0.75 (20)	3.31 (84)	6.63 (168)	2.0 (50)	2.36 (60)	1.42 (36)	6 (2.72)
599-10602...	1 (25)		4.50 (114)		1.00 (25)	3.50 (89)	7.00 (178)				6.8 (3.08)

Dimensions (Continued)

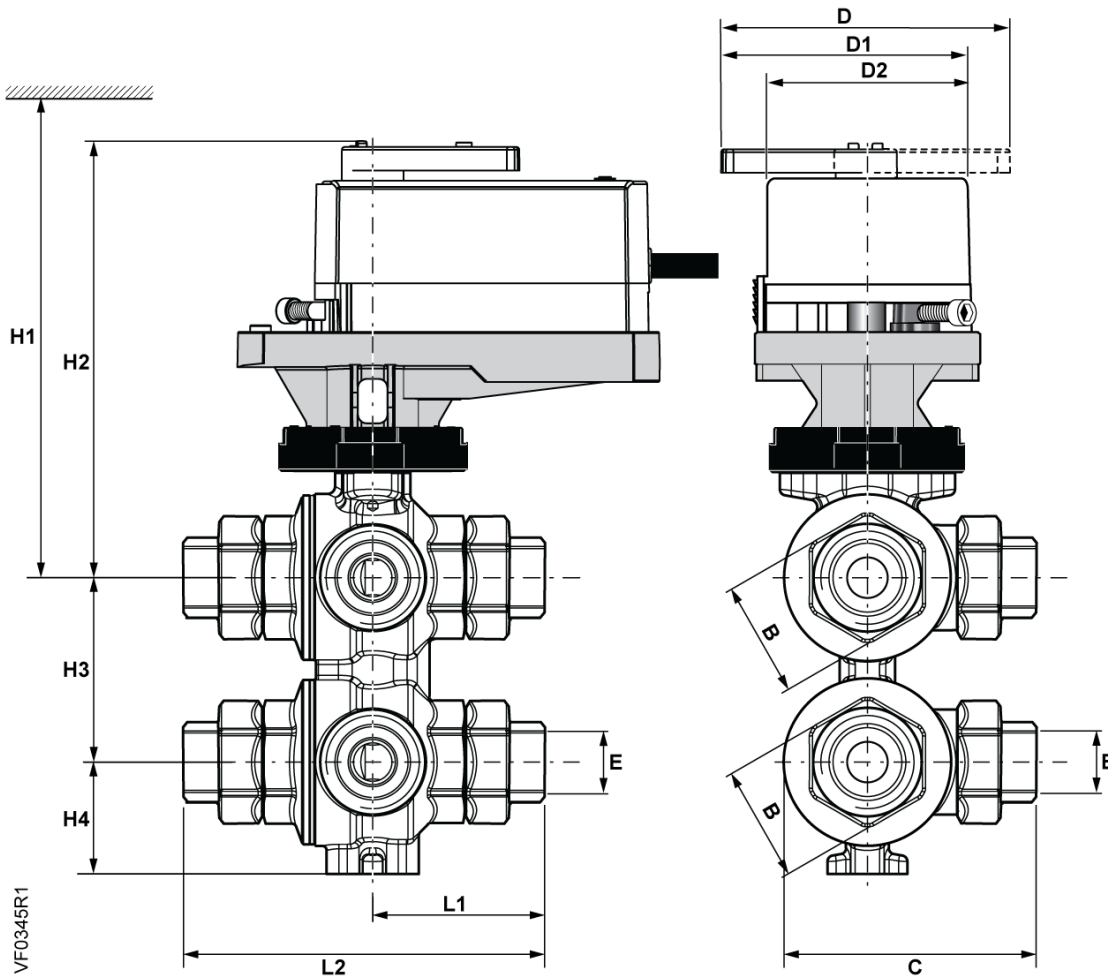

Figure 9. 6-Way Ball Valve with Actuator Dimensions in Inches (Millimeters).

Part Number	Line Size	B	C	D	D1	D2	E	H1	H2	H3	H4	L1	L2	Weight lb (kg)
599-10600...	1/2 (15)	1.00 (25)	3.44 (87)	3.98 (101)	3.44 (88)	2.91 (74)	0.50 (15)	13.75 (349)	5.75 (146)	1.75 (45)	1.13 (29)	2.81 (71)	5.63 (143)	6.8 (3.08)
599-10601...	3/4 (20)	1.50 (38)	4.25 (108)				0.75 (20)			2.36 (60)	1.42 (36)	3.31 (84)	6.63 (168)	7.6 (3.45)
599-10602...	1 (25)		4.50 (114)				1.00 (25)			3.50 (89)	7.00 (178)	8.4 (3.81)		

Information in this publication is based on current specifications. The company reserves the right to make changes in specifications and models as design improvements are introduced. OpenAir is a trademark of Siemens Schweiz AG. Other product or company names mentioned herein may be the trademarks of their respective owners. © 2020 Siemens Industry, Inc.