

POWERS® Controls

134-1861 Humidistat

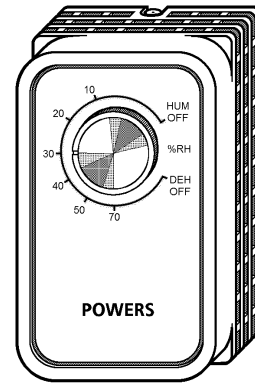

Description

The 134-1861 Humidistat controls humidifying and/or dehumidifying equipment. Typical uses include the control of humidity by ventilation, air conditioning, humidifiers, and dehumidifiers in residential, commercial, and industrial installations.

This humidistat has Single-Pole/Double-Throw (SPDT) snap-acting contacts rated to switch 1/4 hp motors. It has a wide setpoint range of 0 to 70% Relative Humidity (RH), as well as “off” dial positions for humidification and dehumidification. The differential of the 134-1861 is fixed at approximately 6% RH.

Features

- Human Hair Sensing Element – Provides stable, accurate measurement.
- 1/4 HP (6A) Rated Contacts – Permit direct operation of many fans in commercial applications.
- High/low Adjustable Knob Range Stops – Allow adjustments within a desired range.
- Enclosed Pennswitch – Provides dust protection for contacts.
- Mounting Plate – Allows easy mounting and wiring without removing the cover.

Product Number

134-1861

Accessories

| | |
|---|---------|
| Concealed Adjustment Faceplate, Vertical Mounting | 134-034 |
| Aluminum Guard | 134-117 |

Warning/Caution Notations

| | | |
|-----------------|--|---|
| WARNING: | | Personal injury or loss of life may occur if a procedure is not performed as specified. |
| CAUTION: | | Equipment damage or loss of data may occur if the user does not follow a procedure as specified |

Introduction

The 134-1861 Humidistat provides SPDT control for use on low or line voltage applications. It has a thermoplastic cover with an Allen-head locking screw to discourage unauthorized tampering. The sensing element consists of carefully selected and processed human hair.

An adjusting knob and easy-to-read dial allow quick selection of the desired setpoint. The humidistat is supplied with the faceplate installed for vertical mounting and knob adjustment. However, a horizontal faceplate is enclosed for horizontal mounting and knob adjustment if desired. There is also an optional Concealed Adjustment Faceplate (P/N 134-034) available for installations where humidity adjustment by the occupants is not desired.



WARNING:

The low temperature detection thermostat is designed for use only as an operating control. Where an operating control failure would result in personal injury and/or loss of property, it is the responsibility of the installer to add devices (safety, limit controls) or systems (alarm, supervisory systems) that protect against, or warn of control failure.

Operation

The humidistat has a setpoint range of 0 to 70% RH, as well as humidification off (**HUM OFF**) and dehumidification off (**DEH OFF**) positions. At the **HUM OFF** position, the C to L terminal circuit is open and the C to H terminal circuit is closed. At the **DEH OFF** position, the C to H terminal circuit is open and the C to L terminal controls the humidification equipment.

At any given setpoint, the C to L circuit closes on a decrease in relative humidity, and the C to H circuit closes on an increase in relative humidity.

The usual setting in winter is 30 to 40% RH. Lower settings may be necessary in extremely cold weather to prevent condensation on windows, doors, and so on. The same setting should be used where reduction of humidity by means of exhaust fans is provided in well-constructed homes. Summer settings on air conditioning or dehumidifying equipment will usually be near 50% RH.

The suggested indoor humidity at 70°F (21°C) for residential applications on humidifying or dehumidifying equipment in winter is shown in Table 1.

Table 1. Humidity Settings.

| Outside Temperature | Suggested Humidity Setting |
|-------------------------|-----------------------------|
| -20°F (-29°C) and Below | 15% RH |
| -10°F (-23°C) | 20% RH |
| 0°F (-18°C) | 25% RH |
| 10°F (-12°C) | 30% RH |
| 20°F (-7°C) | 35% RH |
| Above 20°F (-7°C) | 40% RH or Higher as Desired |

| Specifications | 120 Vac | 208 Vac | 240 Vac |
|---------------------------------|---|----------------|----------------|
| Contact ratings | | | |
| Full load ampere | 6.0 | 3.5 | 3.0 |
| Locked rotor ampere | 36.0 | 21.0 | 18.0 |
| Pilot duty 125 VA at 24/277 Vac | | | |
| Switch action | SPDT | | |
| Switch | Snap-acting in a dust-protected enclosure | | |
| Range | 0 to 70% RH | | |
| Ambient temperature | 40 to 100°F (4.4 to 38°C) | | |
| Differential | Fixed at approximately 6% RH | | |
| Sensing element | Selected human hair | | |
| Material | | | |
| Case | 0.050 inch (1.27 mm) cold rolled steel | | |
| Cover | Beige thermoplastic | | |
| Finish | | | |
| Base | Zinc plate dichromate dipped | | |
| Cover | Brown markings on gold anodized aluminum | | |
| Mounting | Vertical or horizontal 2 × 4 in. (51 × 102 mm) wall box | | |
| Wiring terminals | Large 8-32 × 1/4 in. binder head screws | | |
| Weight | 0.9 lb. (0.4 kg) | | |
| Dimensions | 4.71 × 2.96 × 2.94 in. (120 × 75 × 75 mm) | | |
| Agency listings | UL Guide No. XAPX; File E6688 CSA Class No. 4813.02 File LR948 | | |

- Mounting and Installation**
- Locate the 134-1861 as follows:
- on an inside wall away from ranges, sinks, bathrooms, or other areas of extreme moisture and temperature.
 - where natural air circulation is unrestricted.
 - where lamps, sunlight, fireplaces, heat registers, radiators, concealed air ducts or pipes, or room occupants will not affect its operation.

- General Guidelines**
-
- Required Tools**
- 2 × 4 in. (51 × 102 mm) wall box (field-supplied)
 - 3-wire cable (field supplied)
 - Screwdriver (slotted standard)
 - Marking pencil
 - Wire strippers

Installation



CAUTION:

Do not remove the humidistat cover during installation. The sensing element must be carefully protected against accidental damage. All wiring and mounting can be completed without removing the cover.



WARNING:

Shock hazard. Disconnect the power supply before wiring connections are made to prevent electrical shock or possible damage to the equipment.

1. Select the proper mounting location (see *General Guidelines*) and install a vertical or horizontal wall box 4 to 5 feet (1.2 to 1.5 m) above the floor.
2. Run conduit or cable, as required by national and/or local electric codes, from the wall box to the equipment to be controlled. Leave approximately 6 inches (152 mm) of wire for connection to the humidistat terminals.
3. Remove the humidistat mounting plate by loosening the mounting plate locking screw (see Figure 1) and lifting and removing the plate from the base.
4. Pull wires through the mounting plate and fasten the plate, grounding screw end up, to the wall box with the screws provided.
5. Strip the wires and connect to the proper terminals on the back of the humidistat. See *Wiring Diagrams*.

NOTE: Use the terminal screws provided (8-32 x 1/4 in. binder head). Substitution of other screws may cause problems in making proper connections.

6. Connect the grounding provision of the humidistat to the branch circuit ground.
7. Hook the two slots in the humidistat base over the projections on the mounting plate and swing the humidistat into place. Push the wires back flush into the wall box.
8. Securely tighten the mounting plate locking screw.

The installation is now complete.

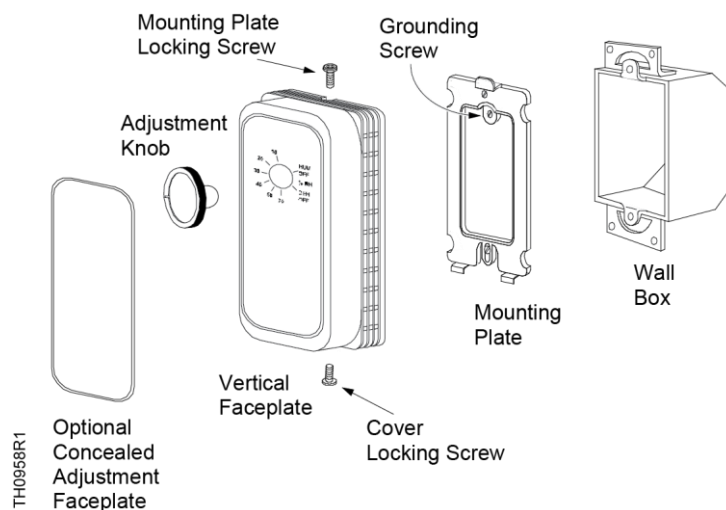

Figure 1. 134-1861 Humidistat.

Mounting and Installation, continued

(Optional) Horizontal Faceplate Installation

1. Mount and wire the humidistat. See *Installation*.
2. Pull the adjustment knob off the humidistat cover.
3. Peel off the backing of the horizontal faceplate.
4. Position the horizontal faceplate over the factory-installed vertical faceplate. Ensure that the plate is positioned straight and even to over the existing plate.
5. Firmly press the horizontal faceplate onto the humidistat cover.
6. Replace the adjustment knob.

The installation is now complete.

Wiring Diagrams

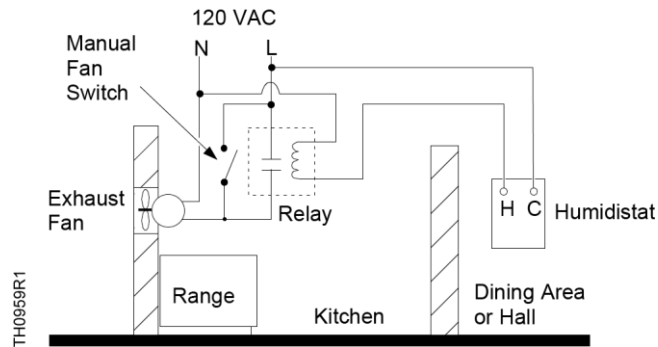

Figure 2. Typical Wiring Diagram of a 134-1861 Used to Reduce Excessive Humidity in a Well-Constructed Building by Manual or Automatic Control of an Exhaust Fan.

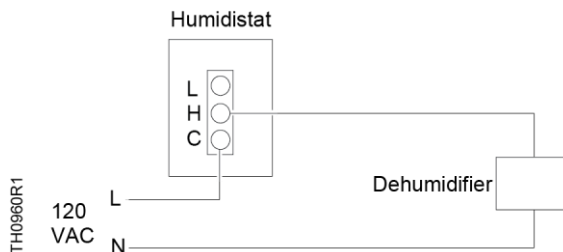

Figure 3. Dehumidification Control Wiring Diagram.

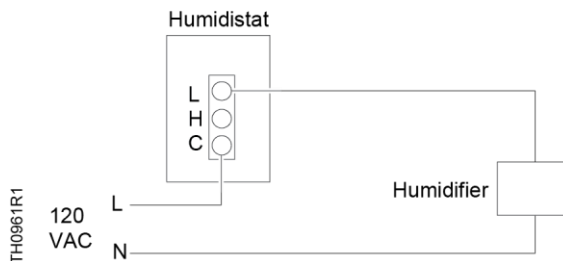

Figure 4. Humidification Control Wiring Diagram.

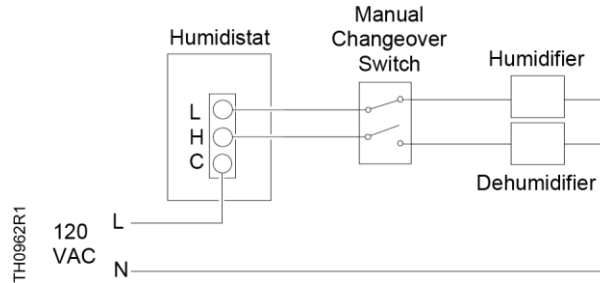

Figure 5. Schematic Wiring Diagram of a 134-1861 Automatically Operating a Humidifier or Dehumidifier as Selected by the Manual Changeover Switch.

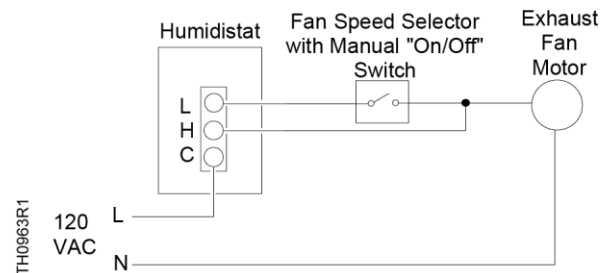

Figure 6. Schematic Wiring Diagram of a 134-1861 Automatically Operating an Exhaust Fan at Full Speed to Control Excessive Humidity. A Combination Speed Control and "On/Off" Switch Permits Manual Operation of an Exhaust Fan at Selected Speeds.

Range Stops

High and low range stops of the humidistat can be field adjusted as desired. Use the following procedures to set the high and low range stops.

High Range Stop

1. Set the adjustment knob to the maximum desired RH setting.
2. Pull the adjustment knob off the humidistat cover.
3. Loosen the bottom cover screw and remove the humidistat cover.



CAUTION:
Equipment damage hazard.

Avoid contact with the human hair sensing element. Contact with the hair element can affect control accuracy and/or product life.

4. While holding the dial firmly in place, keep the setting in line with the calibrating mark, press Tab **A** (see Figure 7) and rotate it counterclockwise until it is against Stop Pin **C**.
5. Release the tab making sure it fits into the nearest notch.
6. Replace the humidistat cover, tighten the bottom cover screw, and replace the adjustment knob.
7. Rotate adjustment knob to desired normal operating setpoint.

Low Range Stop

1. Set the adjustment knob to the minimum desired RH setting.
2. Pull the adjustment knob off the humidistat cover.
3. Loosen the bottom cover screw and remove the humidistat cover.



CAUTION:
Equipment damage hazard.

Avoid contact with the human hair sensing element. Contact with the hair element can affect control accuracy and/or product life.

4. While holding the dial firmly in place, keep the setting in line with the calibrating mark, press Tab **B** (see Figure 7) and rotate it clockwise until it is against the stop pin **C**.
5. Release the tab making sure it fits into the nearest notch.
6. Replace the humidistat cover, tighten the bottom cover screw, and replace the adjustment knob.
7. Rotate adjustment knob to desired normal operating setpoint.

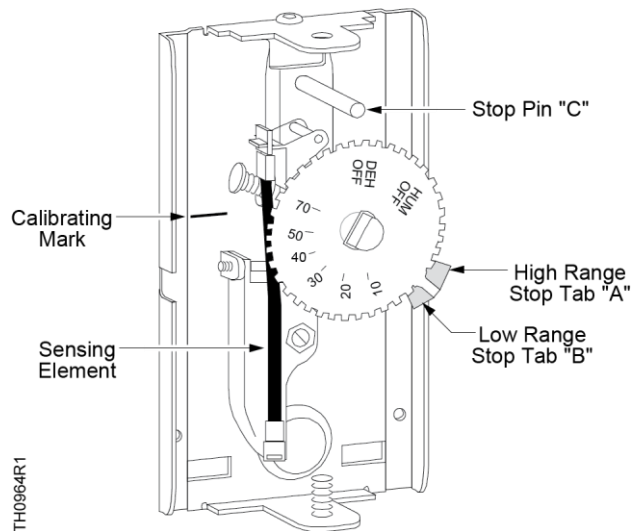

Figure 7. 134-1861 Humidistat Range Tabs and Stop

Dial Lock

The high and low range stops can be set to keep the adjustment knob from rotating. To lock the dial:

1. Set the adjustment knob to the minimum desired RH setting.
2. Pull the adjustment knob off the humidistat cover.
3. Loosen the bottom cover screw and remove the humidistat cover.



CAUTION:
Equipment damage hazard.

Avoid contact with the human hair sensing element. Contact with the hair element can affect control accuracy and/or product life.

Dial Lock, Continued

4. While holding the dial firmly in place, keep the setting in line with the calibrating mark, press Tab **A** and rotate it counterclockwise until it is against Stop Pin **C**. Press Tab **B** and rotate it clockwise until it is against Stop Pin **C**. See Figure 7.
5. Ensure each tab fits into the notch closest to the stop.
6. Replace the humidistat cover, tighten the bottom cover screw, and replace the adjustment knob.

Checkout Procedure

Before applying power, ensure that installation and wiring connections are made according to job specifications.

After all necessary adjustments and electrical connections have been made, put the system into operation and observe at least three complete operating cycles before leaving the installation.

Service

There is no servicing of the humidistat. For a replacement 134-1861, contact your local Siemens Industry representative.

Dimensions

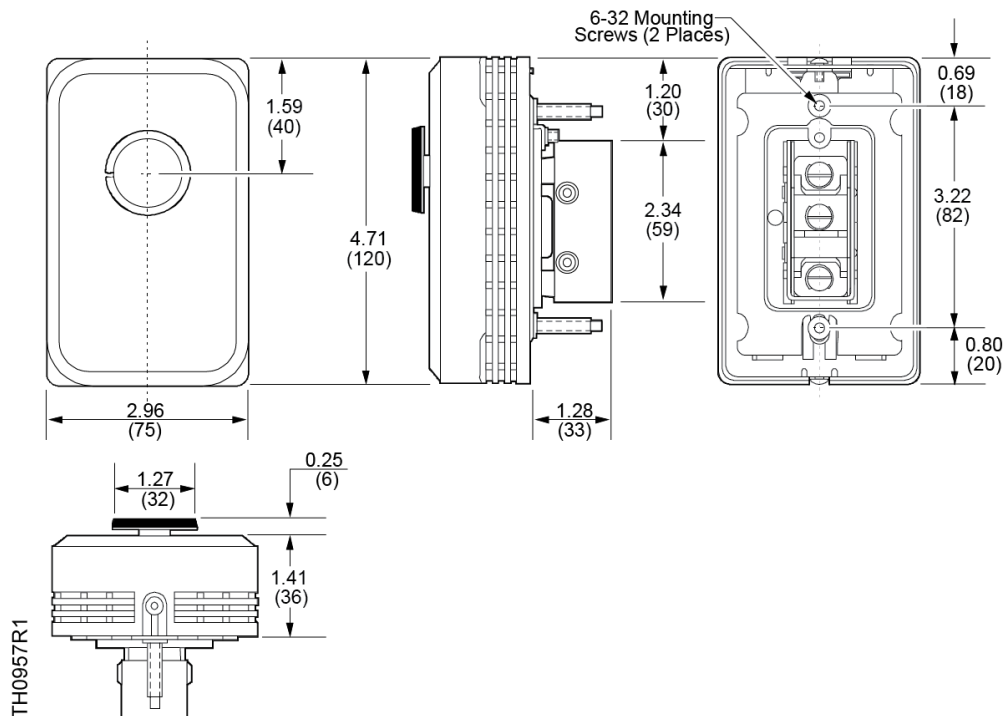

Figure 8. Dimensions of the 134-1861 Humidistat in Inches (Millimeters).

Information in this publication is based on current specifications. The company reserves the right to make changes in specifications and models as design improvements are introduced. POWERS is a registered trademark of Siemens Industry, Inc. Other product or company names mentioned herein may be the trademarks of their respective owners. © 2019 Siemens Industry, Inc.