

A-Series Industrial Electric Actuator (600 to 18,000 lb-in)



Description	The A-Series quarter-turn industrial electric actuator features a compact, reliable design that mounts directly to Siemens resilient seat butterfly valves without the need for brackets and linkages. Available in torque outputs from 600 to 18,000 lb-in (68 to 2,033 Nm), 24V and 120 Vac, Two-position (On/Off) and Modulating units all in NEMA 4x and IP65-rated housings.
Features	<ul style="list-style-type: none">• Compact, lightweight design and direct mounting• High visibility Beacon position indicator• Manual, declutchable override handwheel• Terminal strip for cable terminations• Servo NXT option for modulating control• Travel limit cams adjustable by hand or screwdriver• UL-approved (120 Vac only)• On/off or modulating control• Available in 120, 24 Vac 50/60 Hz, single-phase, 24 Vdc voltages• Output torque 600 lb-in (68 Nm) to 18,000 lb-in (2,033 Nm)• ISO 5211 for direct mounting• All actuators include a heater to prevent condensation build-up• All modulating units include a feedback potentiometer
Servo NXT Features (for Modulating Actuators)	<ul style="list-style-type: none">• Provides precise modulating control of valve position• Single Finger Technology (SFT) menu-driven, pushbutton, programming with LED confirmation of all settings:<ul style="list-style-type: none">○ Input Control – 4 to 20 mA, 0 to 10 Vdc, 0 to 5 Vdc or 2 to 10 Vdc○ Position Feedback – 4 to 20 mA, 0 to 10 Vdc, or 0 to 5 Vdc○ Auto Calibrating○ Fail Position<ul style="list-style-type: none">▪ Loss of supply power – fail-in-place▪ Loss of control signal - selectable○ Adjustable speed control• Including:<ul style="list-style-type: none">○ Manual mode○ Onboard signal generator to simplify field set-up○ Fault display – Simplifies troubleshooting○ Stall detection – Eliminates mechanical damage in case of obstruction or bad switch settings• Optical isolation of all inputs/outputs<ul style="list-style-type: none">○ Provides interoperability with all controllers○ Earth ground tolerant○ Allows for parallel operation
Ordering	Actuators can be ordered separately or together with a valve as an assembly.

Product Numbers Table 1. A-Series Industrial Electric Actuators, 24V.

Product Number	Operating Mode	Voltage 50/60 Hz	Torque		90° Stroke Time*	Current Draw (Amps)	
			(lb-in)	(Nm)		Full Load	Locked Rotor
A126.600	On/Off	24 Vac/dc	600	68	60 sec. AC 40 sec. DC	1.80	--
A126.2K			2,000	226	60 sec.	2.00	--
A126.5K			5,000	565	60 sec.	4.00	--
A166.600	Modulating	24 Vac	600	68	60 sec.	1.80	--
A166.2K			2,000	226	60 sec.	2.00	--
A166.5K			5,000	565	60 sec.	4.00	--

* Operating times shown are with 60 Hz power supply. Actuators with 50 Hz power supply will be 20% slower.



Table 2. A-Series Industrial Electric Actuators, 120V.

Product Number	Operating Mode	Voltage 50/60 Hz	Torque		90° Stroke Time*	Current Draw (Amps)	
			(lb-in)	(Nm)		Full Load	Locked Rotor
A226.600	On/Off	120 Vac	600	68	30 sec.	0.80	1.00
A226.1K			1,200	135	30 sec.	0.78	2.10
A226.2K			2,000	226	30 sec.	1.00	2.10
A226.3K			3,000	339	30 sec.	1.20	3.00
A226.5K			5,000	565	30 sec.	1.60	3.00
A226.6K			6,500	734	30 sec.	2.30	3.10
A226.13K			13,000	1,470	110 sec.	2.30	3.10
A226.18K			18,000	2,034	110 sec.	2.50	3.10
A266.600	Modulating	120 Vac	600	68	30 sec.	0.80	1.00
A266.1K			1,200	135	30 sec.	0.78	2.10
A266.2K			2,000	226	30 sec.	1.00	2.10
A266.3K			3,000	339	30 sec.	1.20	3.00
A266.5K			5,000	565	30 sec.	1.60	3.00
A266.6K			6,500	734	30 sec.	2.30	3.10
A266.13K			13,000	1,470	110 sec.	2.30	3.10
A266.18K			18,000	2,034	110 sec.	2.50	3.10

* Operating times shown are with 60 Hz power supply. Actuators with 50 Hz power supply will be 20% slower.

NOTE: 13K and 18K torque models are available starting July 2020.

Warning/Caution Notations

WARNING:		Personal injury or loss of life may occur if you do not perform a procedure as specified.
CAUTION:		Equipment damage may occur if you do not perform a procedure as specified.



CAUTION:



Do not install or use the A-Series Industrial Electric Actuator in or near environments where corrosive substances or vapors could be present. Exposure of the electric actuator to corrosive environments may damage the internal components of the device and will void the warranty.

Application

These actuators are ideal for use on valves for chillers, cooling towers, boilers, heat exchangers and other indoor or outdoor applications. The actuators' advanced electronics assure reliable compatibility with virtually any analog control signal used in today's building automation and temperature control systems.

All Siemens A-Series Industrial actuators are NEMA 4X rated for protection against the elements and are suitable for outdoor applications. The NEMA 4x rated housing prevents any water ingress in outdoor applications. The heater prevents any condensation build-up inside the housing.

Warning/Caution Notations

WARNING:		Personal injury or loss of life may occur if you do not perform a procedure as specified.
CAUTION:		Equipment damage may occur if you do not perform a procedure as specified.



CAUTION:

Do not install or use the A-Series Industrial Electric Actuator in or near environments where corrosive substances or vapors could be present. Exposure of the electric actuator to corrosive environments may damage the internal components of the device and will void the warranty.

A-Series Industrial Electric Actuator

Specifications

Operating Conditions

Ambient Temperature	-20 to 150°F (-29° to 65°C)
Fail Position	Loss of supply power - fail-in-place
Motor Insulation	
120 Vac	Class F, 311°F (155°C) thermal trip at 275°F (135°C)
24 Vac/dc	Class B, Slow Blow Fuse 5A @ 250 Vac

Physical Description

Housing	ASTM B85 Pressure Die Cast Aluminum, Polyester Powder Coated
Motor	
120 Vac	Single-Phase, Reversible, Permanent Split Capacitor Induction Motor
24 Vac/Vdc	Single-Phase, Permanent Magnet-Brush D.C. Motor
Auxiliary/Limit Switches SPDT	
120 Vac	10A- 1/3 HP
12 Vdc	2A
Terminal Strip	
Switch Plate	12 to 22 AWG (2.0 to 0.65 mm)
Servo	14 to 24 AWG (1.63 to 0.51 mm)
Heater	5-Watt, PTC style
Dimensions and weight	See Dimensions.
Enclosure	Designed to meet NEMA Type 4, 4x and IP65 specifications
Travel stops	Externally adjustable at both 0 and 90 degrees.
Conduit entries	
600 lb-in	Two 1/2" NPT (BSP)
1200 lb-in and higher	Two 3/4" NPT
Manual operation	Pull to engage, push to disengage - 30:1 drive ratio, 12 and 18K lb.-in. models are 90:1
Certifications	UL508 certified (120 Vac only)

Servo Specifications (for Use with Modulating Actuators)

Power Requirements		120 Vac 50/60 Hz +/- 10% 24 Vac 50/60 Hz +/- 10% 24 Vdc -10%, +30% 5 VA average (no load) Fuse: 5A Slow Blow 5 mm x 20 mm
Input Signal	Control Signal	4 to 20 mA, 0 to 10 Vdc, 0 to 5 Vdc, 2 to 10 Vdc
	Input Impedance	>100 Meg Ohms (0 to 10V, 2 to 10V, 0 to 5V)
Output Signal	Operating Modes	4 to 20 mA, 0 to 10 Vdc, 0 to 5 Vdc
	Output Impedance	<10 Ohms (0 to 5 Vdc, output, 0 to 10V output) 200 Ohms (4 to 20 mA output mode)
	Loop Voltage	12 Vdc (4 to 20 mA output mode)
Resolution	Absolute Position Accuracy	<1%
	Dead Band Adjustment	1% (+/- 0.5%) to 6% (+/-3%) (3% default) 1% minimum increment
Potentiometer Feedback Signal	Supply Voltage	3.3 Vdc
	External Feedback Potentiometer	1K to 10K Ohms
Speed Control	Open/Close Speed Actuator	0% to 100% (default). Step size: 20%. open/close speed as a percentage of full speed.(See motor speed specification for maximum 90° run times.)
Operating Mode	Normal Mode	Modulating – follow setpoint
	Loss of Control Signal	Selectable to Open, Close, or Last
	Loss of Supply Power	Fail-in-place
	Reverse Acting Mode	Configurable for inverted input signal
	Autocalibration	Automatic endpoint detection
	Manual Operation	Keypad electrical manual operation of actuator (Open, Stop, Close)
Torque Protection	Stall Detection	Motor detected stationary >2 seconds (600 to 6500 lb-in units only)
	Torque Limit Open/Close torque	(Optional) externally connected limit switch
	Electronic Torque Limit current/torque	(Optional) factory-programmable limit switch
Environmental	Ambient Temperature	-20°F (-29°C) to 150°F (65°C)
	Compliance	120V units comply with UL, cUL, and CSA. All models are CE certified.

Table 3. Product Numbers.

Use the product numbers in the following table to order a valve or a valve and actuator assembly. The valve product number consists of the type, action, valve size, disc type, and valve configuration. To order an assembly, add a (-) after the valve product number and then choose the application, actuator, voltage, control signal, end switches followed by a separator (.) and the actuator torque.

Sample:	B	2	02	F	C	-	S	A	1	2	6	.	600
Valve Type: Butterfly													
Action: 2 = 2-Way 3 = 3-Way													
Valve Size: 02=2", 25=2.5", 03=3", 04=4", 05=5", 06=6", 08=8" 10=10", 12=12", 14=14", 16=16", 18=18", 20=20", 24=24"													
Disc Type: F = Full Cut U = Under Cut													
Valve Configuration: 3-Way - A, B, C, D 2-Way O = Normally Open C = Normally Closed M = Valve assembly with manual operator													
Denotes Assembly													
Application: S = Standard Temp – Intermittent 250°F Operation H = High Temperature – Continuous 250°F Operation Blank = Siemens Commercial Actuator													
Actuator: A = Industrial Actuator GCA = Siemens SR Commercial Actuator GIB = Siemens NSR Commercial Actuator													
Voltage: 1 = 24V 2 = 120V													
Control Signal: 2 = 2-Position 3 = Floating (Commercial Actuators only) 6 = Modulating (0-10V)													
End Switches: 1 = No switches 6 = Switches													
Separator													
Actuator Torque (lb-in): 600=600, 1K=1200, 2K=2000, 3K=3000, 5K=5000, 6K=6500, 13K=13000, 18K=18000, 21K=21300, 41K=40680, 3U = Shaft adapter with 3-foot cable (Commercial Actuators only)													

NOTE: 13K and 18K torque models are available starting July 2020.

Accessories/Kits	Part Number	Description
	599-10097LT	120V Servo NXT Kit A-Series 600 to 6.5K lb-in actuators
	599-10097HT	120V Servo NXT Kit for A-Series 13K & 18K lb-in actuators
	599-10098	24V Servo NXT Kit A-Series 600 to 5K lb-in actuators

Mounting and Installation

All A-Series industrial electric actuators are suitable for direct mounting on Siemens resilient seat butterfly valves.

NOTE:

The standard mounting position for the actuator is to orient the base of the actuator parallel to the pipeline.

To mount an actuator on a vertical pipe, position the unit with the conduit entries on the bottom to prevent condensation from entering the actuator through its conduits.

Service

The resilient seat butterfly valve and actuator are maintenance-free.

Wiring

CAUTION:



- When wiring an A-Series Industrial Electric Actuator for two-position (on/off) control and the power to the actuator is commanded to be off, you must ensure that there is no extraneous or leakage voltage between hot and common. Leakage voltage greater than 3 Vac can cause actuator failure.
- When wiring an A-Series Industrial Electric Actuator for two-position control, the controller should use at minimum a one-second time delay for command signal reversal. Instantaneous command reversals may cause actuator failure.

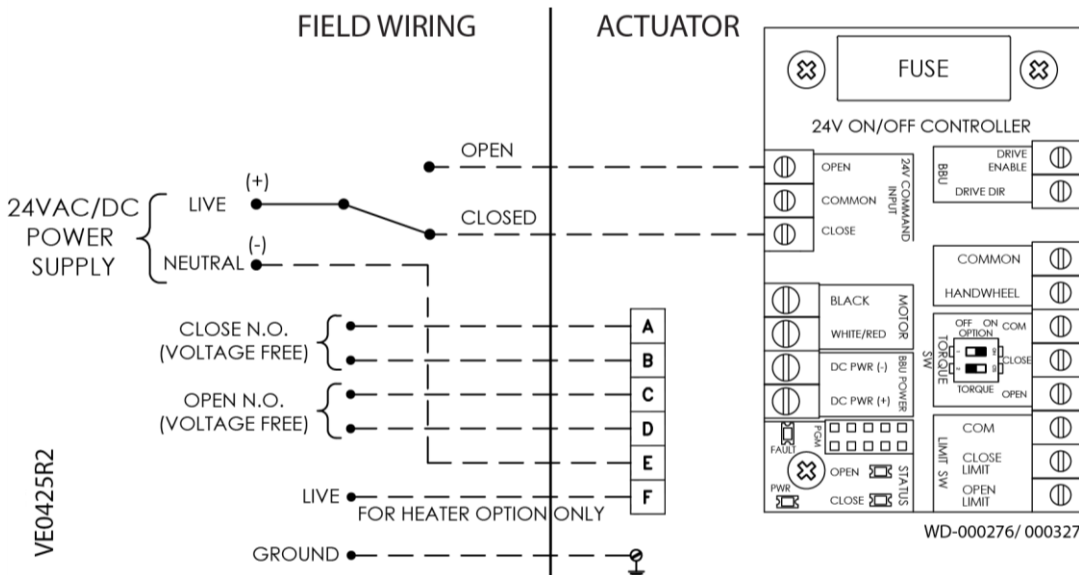

Figure 1. 24 Vac/dc On/Off Wiring 600 and 2000 lb-in Models.

NOTE:

Use this A-Series Industrial Electric Actuator only to control equipment under normal operating conditions. Where failure or malfunction of the electric actuator could lead to personal injury or property damage to the controlled equipment or other property, additional precautions must be designed into the control system. Incorporate and maintain other devices such as supervisory or alarm systems or safety or limit controls intended to warn of, or protect against, failure or malfunction of the electric actuator.

Wiring, Continued

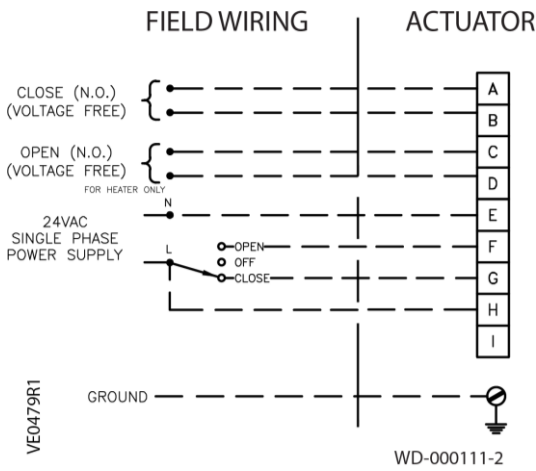

Figure 2. 24 Vac On/Off Wiring 5000 lb.-in. Models.

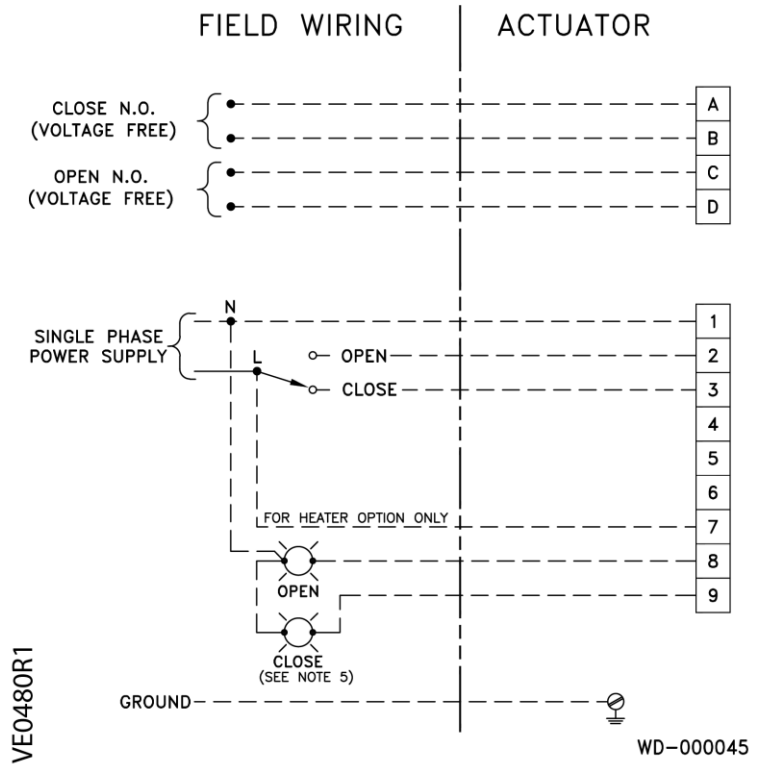

Figure 3. 120 Vac On/Off Wiring, All Models.

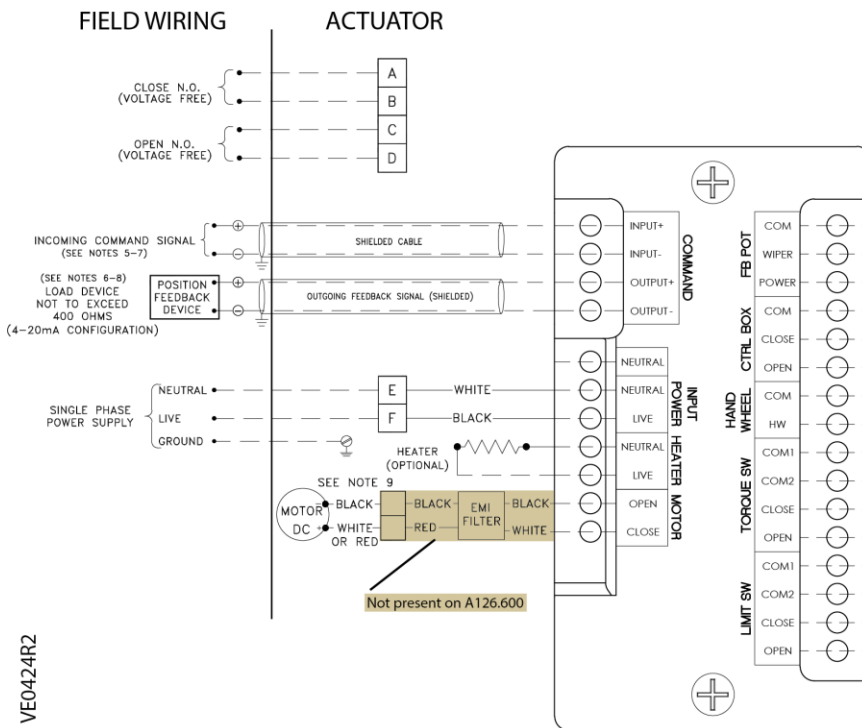
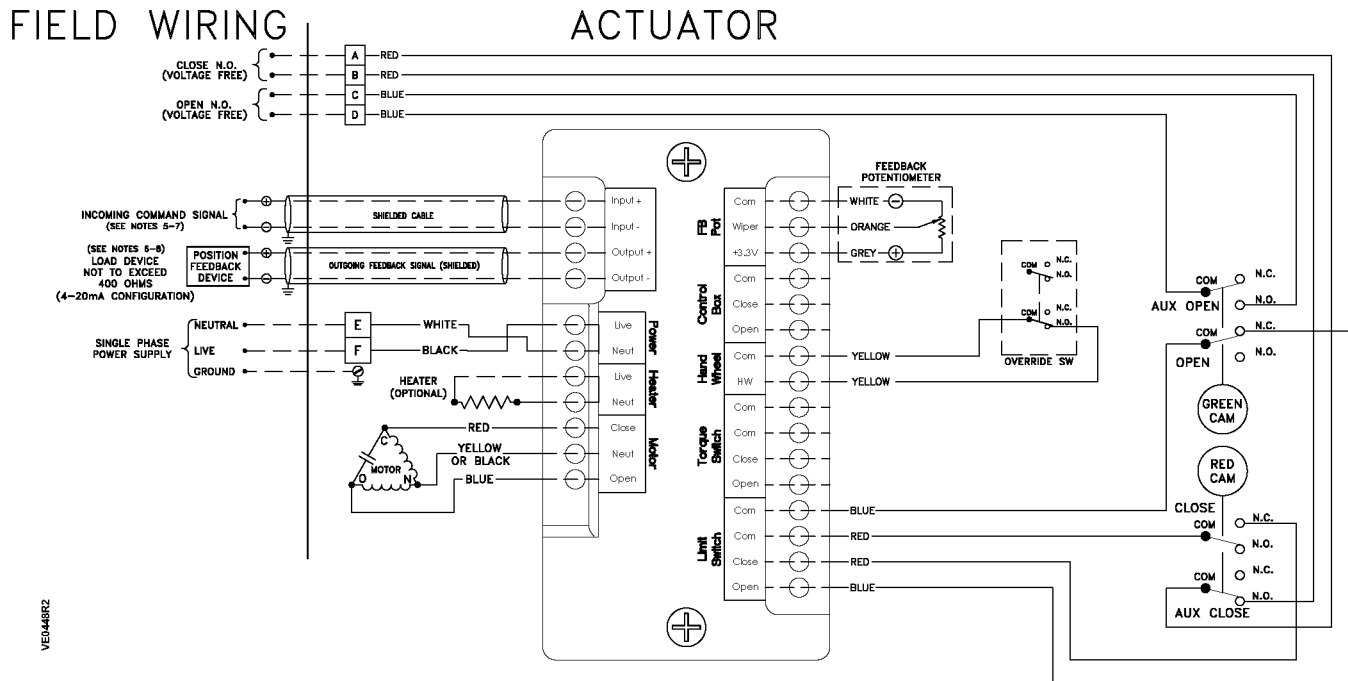

Figure 4. 24 Vac Modulating.

NOTES:

1. Command signal and feedback wires **MUST** be shielded and grounded for proper servo operation.
2. The command signal input (-) terminal is internally connected to the Servo neutral terminal. DO NOT connect the live to the neutral terminal on the Servo.
3. Command signal and feedback signal must be isolated from each other and any other circuits. When using 0 to 10 Vdc, 0 to 5 Vdc and 2 to 10 Vdc the common of the command signal should NOT be ground/earth referenced.
4. The feedback loop is powered by the Servo, do not supply external power.
5. Command signal and feedback signal wires should be properly shielded and grounded, on one end only, preferably the controller end.
6. The 24V Servo Pros can be wired with 3- or 4-wire configuration.

Wiring, Continued



VED48R2

Figure 5. 120 Vac Modulating.

Dimensions

Actuator Model Number	A	B	C	D	E	F	G	H	J	K	L	M	N	P	Q	R	S	Wt lbs (kgs)
Axx6.600	7.5 (191)	5.8 (147)	5.6 (141)	1 (48)	1.94 (49.2)	.19 (4.7)	1/2	2.2 (55)	5/16-18 xØ 2.76 (F07)	-	L75 (19)	.51 (31)	1.75 (44.5)	3.5 (89)	-	-	-	13 (6)
Axx6.1K Axx6.2K	10.1 (256)	7.8 (198)	6.6 (168)	2.4 (62)	2.69 (68.3)	.56 (14.3)	3/4	2.6 (66)	1/2-13 x Ø4.92 (F12)	1/2-13 x Ø 6.50 (F16)	1.18 (30)	.87 (22)	2.22 (56.3)	8.0 (203)	8.0	8.0	8.0	28 (13)
Axx6.3K Axx6.5K Axx6.6K	12.1 (308)	9.5 (242)	7.2 (183)	2.9 (73)	3.19 (80.9)	.56 (14.3)	3/4	3.1 (78)	1/2-13 x Ø4.92 (F12)	3/4-10 x Ø 6.50 (F16)	See Detail A1			12 (304.8)	-	-	-	48 (22)
Axx6.13K Axx6.18K	12.1 (308)	9.5 (242)	12.5 (317)	8.1 (206)	9.2 (234)	.56 (14.2)	3/4	8.3 (211)			See Detail A1			12 (305)	6.1 (155)	12.7 (323)	8 (203)	118 (54)

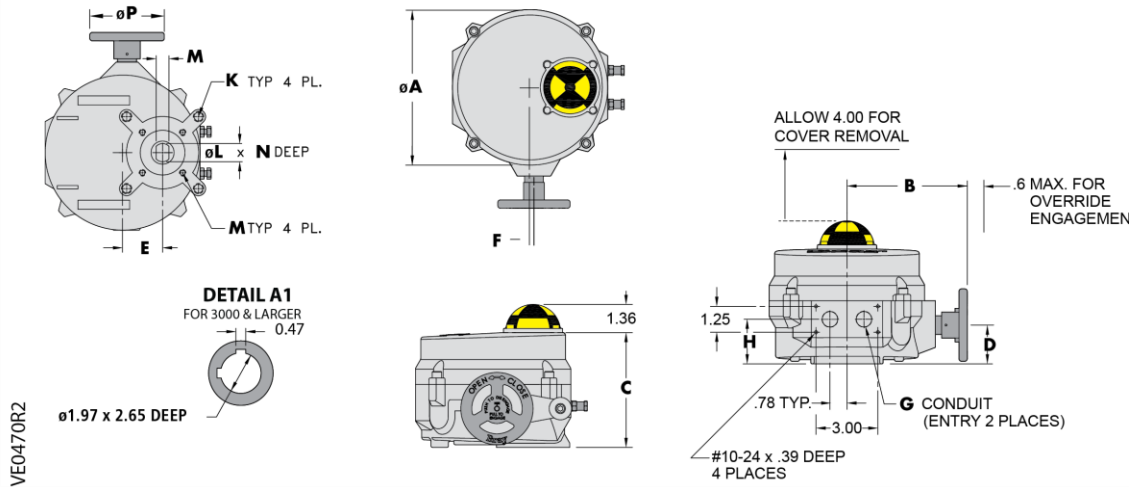

Figure 6. Models Axx6.600 to Axx6.6K

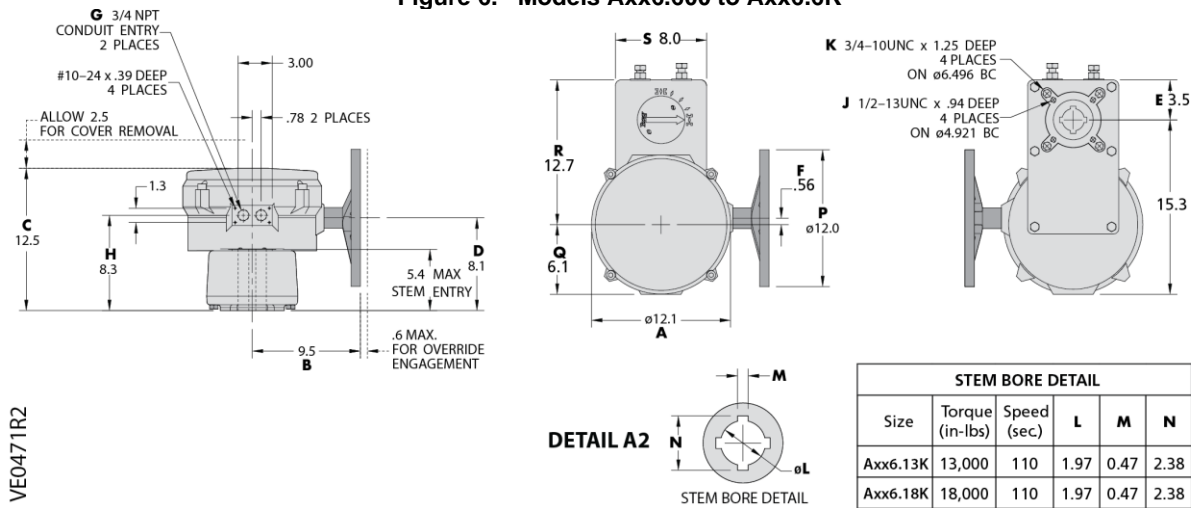

Figure 7. Models Axx6.13K and Axx6.18K.

Information in this publication is based on current specifications. The company reserves the right to make changes in specifications and models as design improvements are introduced. Products or company names mentioned herein may be the trademarks of their respective owners. © 2020-2022 Siemens Industry, Inc.