

Symaro™

Room relative humidity and temperature sensor Modbus RTU

QFA3150/MO



QFA3150/MO



QFA3150/MO + AQF3100

Relative humidity (high accuracy) and temperature sensor with Modbus communication

- Modbus RTU (RS-485)
- High measuring accuracy across the entire measuring range
- DIP switches setting together with other controllers
- With the AQF3100 accessory for outdoor use

Use

The sensor is used in ventilation and air conditioning plants where high accuracy and short response times for measuring temperature and relative humidity are required. The measuring range covers the entire humidity range of 0...100 %.

Examples

- Storage and production facilities in the paper, textile, pharmaceutical, food, chemical and electronics industry, and so on.
- Laboratories
- Hospitals
- Computer and EDP centers
- Indoor swimming pools
- Greenhouses
- With the AQF3100 accessory for outdoor use

The sensor is used as a

- control sensor in the supply or exhaust air
- limit sensor for maximum limitation of supply air humidity after a steam humidifier
- limit sensor, for example, for measured value indication or for connection to a building automation and control system

Technical design

Cable entry is made via the screwed cable gland M16 supplied with the sensor, which can be screwed into the housing.

If the sensor is used outdoors, the opening must be closed off and the prepared hole on the opposite side of the base must be knocked out.

Outdoor mounting kit AQF3100

The outdoor mounting kit consists of:

- 1 wall mounting bracket complete with radiation shield
- 4 Phillips-head screws K35 × 12
- 1 grommet M 16 × 1.5 with O-ring and nut M 16 × 1.5 for closing off the sensor's cable entry hole if not required

Type summary

Product number	SSN NO.	Temperature measuring range	Humidity measuring range	Operating voltage	Output signal
QFA3150/MO	S55720-S535	-40...70 °C	0...100 %	AC 24 V ±20 %/ DC 13.5...35 V	Modbus RTU

Ordering and delivery

When ordering, specify name and product number, e.g.: Room sensor QFA3150/MO. The outdoor mounting kit AQF3100 listed under Accessories must be ordered as a separate item.

Accessories (not included in standard delivery)

Name	Type reference
Outdoor mounting kit (incl. radiation shield)	AQF3100
Filter cap (for replacement)	AQF3101

Name	Type reference
Measuring tip (exchangeable for replacement)	AQF3150
Service set (for function test)	AQF3153
3 m cable for remote measurement	AQY2010

Notes

Engineering

Powering the sensor requires a transformer for safety extra low-voltage (SELV) with separate windings for 100 % duty. When sizing and protecting the transformer, comply with all local safety regulations.

When sizing the transformer, determine the power consumption of the room sensor.

For correct wiring, see the datasheets of the devices with which the sensor is used.

Observe permissible line lengths.

Cable routing and cable selection

Note that when routing cables, the longer the cables run side by side and the smaller the distance between them, the greater the electrical interference. Shielded cables must be used in environments with EMC problems.

Twisted pair cables are required for the secondary supply lines and the signal lines.

Mounting

Interior mounting (without AQF3100)

Mounting location

Inside wall (not on outside wall!) of the room to be air conditioned; not in recesses, behind curtains, above or close to heat sources or shelves; not on walls behind which a chimney is located.

The sensor must not be exposed to direct solar radiation.

Install the sensor in the occupied space about 1.5 m above the floor and at least 50 cm from the next wall.

CAUTION!

- The degree of protection IP65 is not ensured if the seal between the base and cover is removed.
- The sensing elements inside the measuring tip are sensitive to impact. Avoid any impact on mounting.

Mounting position

Without using the AQF3100 outdoor mounting kit, the sensor must not be mounted with the measuring tip pointing upward.

Mounting instructions

Mounting instructions are printed on the package.

Outdoor mounting (with AQF3100)

Mounting location

Exterior wall, preferably on the North or Northwestern side of the building; if possible in the middle of the wall, at least 2.5 m above the ground.

Not above or below windows, above doors and ventilation shafts, below balconies or eaves.

Mounting position

The sensor with AQF3100 must be mounted in a vertical position (radiation shield at the top).

Mounting instructions

Mounting Instructions are enclosed with the AQF3100.

NOTICE! When using the AQF3100 outdoor mounting kit, the sensor's cable entry hole must be closed off with the grommet and the prepared M16 cable entry on the opposite side knocked out.

Disposal



This symbol or any other national label indicate that the product, its packaging, and, where applicable, any batteries may not be disposed of as domestic waste. Delete all personal data and dispose of the item(s) at separate collection and recycling facilities in accordance with local and national legislation.

For additional details, refer to [Siemens information on disposal](#).

Technical data

Function	
Communication	Modbus RTU (RS-485)
Supported baud rate	9600; 19200; 38400; 57600; 76800; 115200
Transmission format	1-8-E-1; 1-8-O-1; 1-8-N-1; 1-8-N-2
Bus termination	120 ohm, jumper selection

For detailed information about specific functions, see Basic documentation (A6V12297475 *).

Power supply	
Operating voltage	AC 24 V \pm 20 % or DC 13.5...35 V (SELV) or AC/DC 24 V class 2 (US)
Frequency	50/60 Hz at AC 24 V
External supply line protection	Fuse slow max. 10 A or Circuit breaker max. 13 A Characteristic B, C, D according to EN 60898 or Power source with current limitation of max. 10 A
Power consumption	\leq 1.5 VA

Functional data	
Humidity sensor	
Measuring range	0...100 % r.h.
Measuring accuracy at 23 °C and AC/DC 24 V in 0...100 % r.h.	\pm 2 % r.h.
Temperature dependency	\leq 0.05 % r.h./°C
Time constant	< 20 s

Functional data	
Temperature sensor	
Measuring range	-40...70 °C
Measuring accuracy at AC/DC 24 V in 23 °C 15...35 °C -35...+70 °C	±0.3 K ±0.6 K ±0.8 K
Time constant	8.5 min. (according to airflow and wall coupling)

Ambient conditions and protection classification	
Protection degree of housing <ul style="list-style-type: none"> • Base unit • Measuring tip • Unit with outdoor mounting kit 	EN 60529 <ul style="list-style-type: none"> • IP65 • IP40 • IP65
Protection class	III according to EN 60730-1
Environmental conditions Transport <ul style="list-style-type: none"> • Climatic conditions <ul style="list-style-type: none"> – Temperature – Humidity Operation <ul style="list-style-type: none"> • Climatic conditions <ul style="list-style-type: none"> – Temperature (housing with electronics) – Humidity 	-40...70 °C < 95 % r.h. -40...70 °C 0...100 % r.h. (with condensation)

Standards, directives and approvals	
Product standard	EN 60730-1, EN 60730-2-9, EN 61000-6-2, EN 61000-6-3 Automatic electrical controls for household and similar use
Electromagnetic compatibility (Applications)	For use in residential, commerce, light-industrial and industrial environments
EU conformity (CE)	A5W00171680A *)
RCM conformity	A5W00171677A *)
UL	UL 873, http://ul.com/database
UKCA	A5W00178368A *)
Environmental compatibility	The product environmental declaration (A5W00159346A *) contains data on environmentally compatible product design and assessments (RoHS compliance, materials composition, packaging, environmental benefit, disposal).

General	
Cable lengths for measuring signals Perm. cable lengths	See data sheet of the device handling the signal
Electrical connections screw terminals	1 × 2.5 mm ² or 2 × 1.5 mm ²

General	
Cable entry gland (enclosed)	M 16 × 1.5
Materials and colors	
Base	Polycarbonate, RAL 7001 (silver-grey)
Housing cover	Polycarbonate, RAL 7035 (light-grey)
Measuring tip	Polycarbonate, RAL 7001 (silver-grey)
Filter cap	Polycarbonate, RAL 7001 (silver-grey)
Mounting bracket	PA, RAL 7035 (light-grey)
Cable entry gland	PA, RAL 7035 (light-grey)
Sensor (complete assembly)	Silicone-free
Packaging	Corrugated cardboard
Weight including package	Approx. 169 g

*) The documents can be downloaded from <http://siemens.com/bt/download>.

Diagrams

Connection terminals

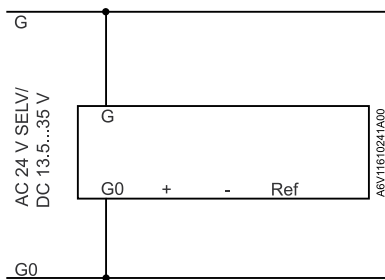

G	Operating voltage AC 24 V ±20 % or DC 13.5...35 V
G0	Ground
+	RS485 Modbus A
-	RS485 Modbus B
Ref	GND_ISO

Without AQF3100

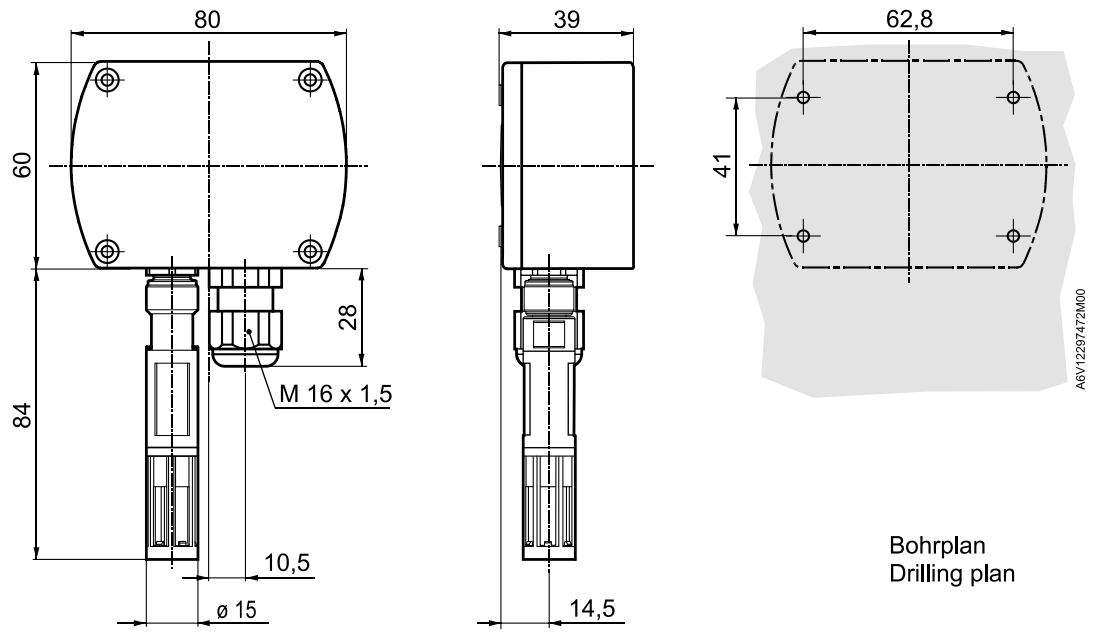

With AQF3100

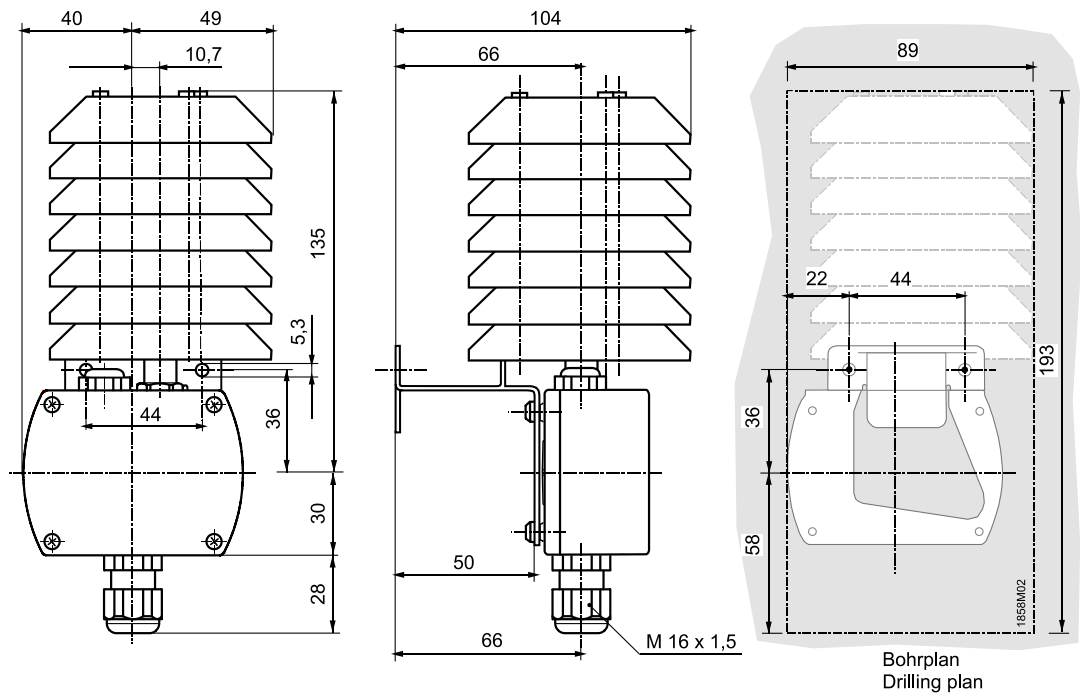

Dimensions in mm

Issued by
Siemens Switzerland Ltd
Smart Infrastructure
Global Headquarters
Theilerstrasse 1a
CH-6300 Zug
+41 58 724 2424
www.siemens.com/buildingtechnologies

© Siemens Switzerland Ltd, 2021
Technical specifications and availability subject to change without notice.

Document ID A6V12297472_en--_b
Edition 2022-10-18