

O-ring assembly replacement instruction

	
<p>VPF54.100F70</p>	<p>O-ring Lubricating grease, Sintono Mega 2KL</p>
<p>VPF54.100F90</p>	
<p>VPF44.100F70</p>	
<p>VPF44.100F90</p>	
<p>599-07332</p>	
<p>599-07337</p>	

1 Remove DPR

①

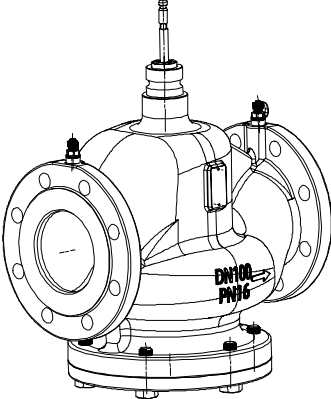
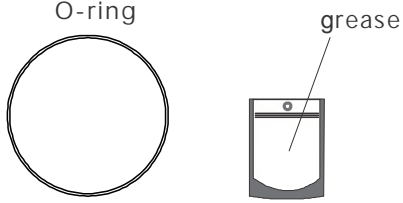
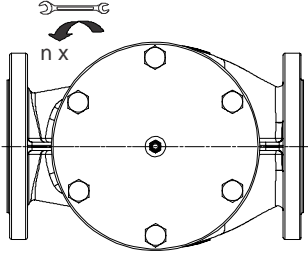

n x

	DN100	4-inch
 (mm)	24	24

A6V13459977203

②

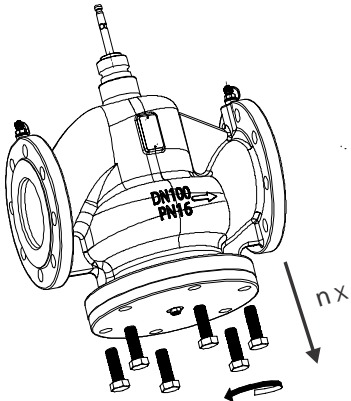

n x

A6V13459977200

③

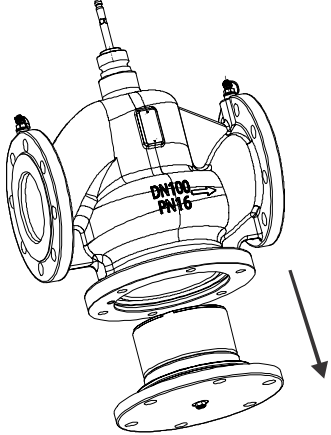

A6V13459977201

2 Remove existing O-ring



- 3 Check choke plug is in position. Lubricate O-ring with supplied grease. Put on new O-ring into the O-ring groove of the flange plate. See notes 1-3 below for more details.

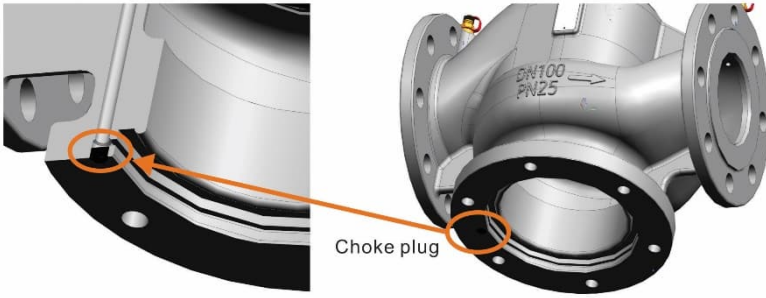

Note:

- 1 Check choke plug is in position. If the choke plug is not in place, the valve doesn't work properly.
- 2 Lubricate O-ring with 2 g provided grease (Sintno Mega 2KL) before putting into groove.
- 3 The O-ring should be in groove evenly, ensure that the O-ring is not twisted and is fully seated into groove without any protrusion.

- 4 Re-install the DPR component

①

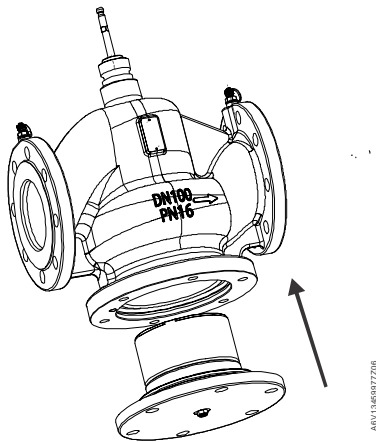

②

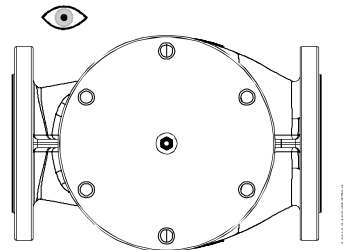

③

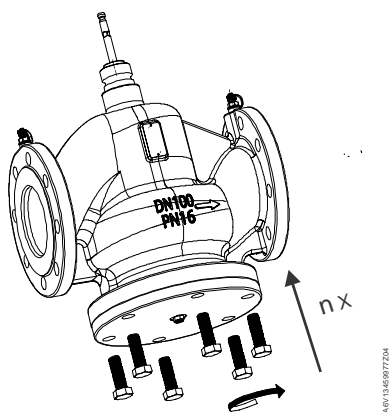

④

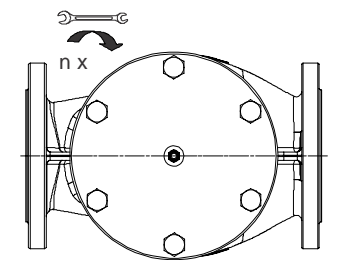

	DN100	4-inch
(mm)	24	24
MA (Nm)	110-125	110-125
MA (ft. lbs.)	81-92	81-92
n	6	6