

Flowrite™ AP 599 Series 12-inch Pneumatic Valve Actuator

Product Description



The Flowrite AP 599 Series 12-inch Pneumatic Valve Actuator is designed for use with the Flowrite VF 599 Series Valves with a 3/4-inch (20 mm) or 1-1/2 inch (40 mm) stroke.

Product Numbers

599-01000

599-01010

Warning/Caution Notations

WARNING		Personal injury/loss of life may occur if a procedure is not performed as specified.
CAUTION		Equipment damage, or loss of data may occur if the user does not follow procedure as specified.

Required Tools

- 24 and 30 mm open-end wrenches
- 3/8, 9/16, and 1-1/16 inch open-end wrenches

Expected Installation Time

60 minutes for field mounting of the actuator

100 minutes for removing and replacing an actuator

Prerequisites



WARNING:

If mounting the actuator to a valve already in line, either close the shut-off valves in the piping (upstream first, then downstream) or switch off the pump to allow the differential and static pressure in the valve to drop.



CAUTION:

Do not damage or scratch the polished surface of the valve stem.

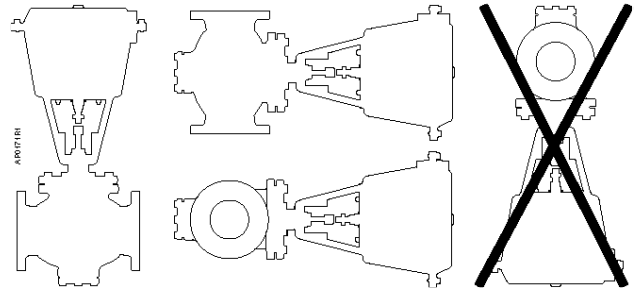

Figure 1. Acceptable Mounting Positions.

The vertical position is recommended for mounting. *Figure 1* shows the acceptable mounting positions.

Installation

Begin with the instructions of *Figure 3* if you are not replacing an existing actuator.

Removing an existing actuator from a valve

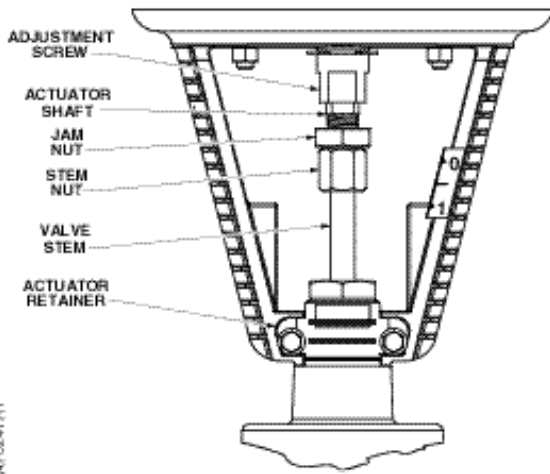

Figure 2.

1. Hold the stem nut firmly with a 24 mm open-end wrench. Using a 33 mm open-end wrench, loosen the jam nut.
2. Hold the actuator shaft firmly with a 9/16-inch open-end wrench. Using the 24 mm open-end wrench, loosen the stem nut from the actuator shaft and lower the valve stem.
3. Using a 3/8-inch open-end wrench, remove the two actuator retainer screws.
4. Remove the actuator retainer from the actuator, and carefully remove the actuator from the valve body being careful not to scratch the valve stem.
5. Remove the stem nut from the valve stem. Remove and discard the stem retainer washer.

Before mounting an actuator to a valve

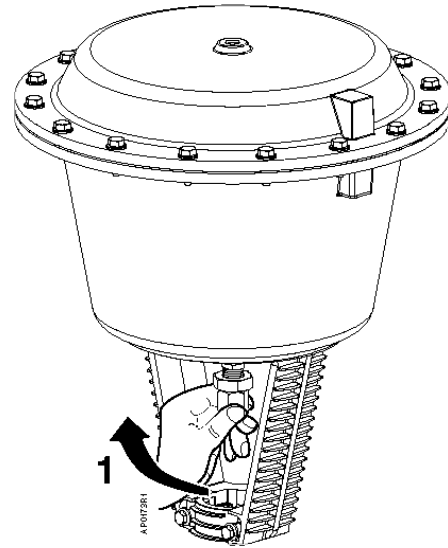

Figure 3.

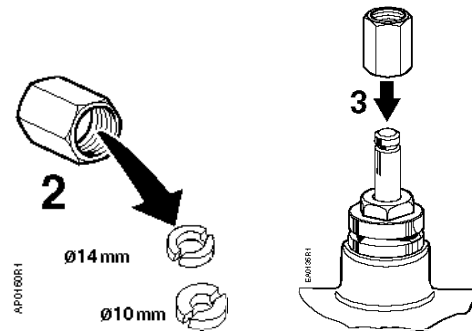
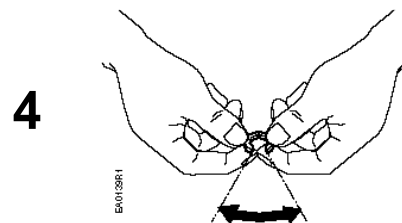

Figure 4.



NOTE: Be careful not to break the washer.

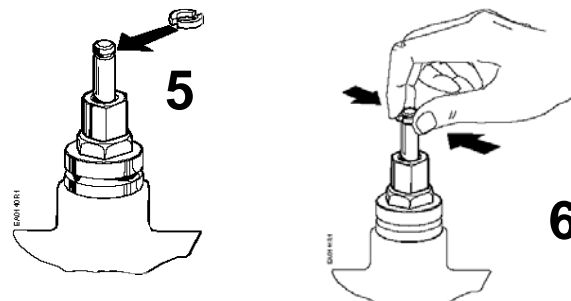

Figure 5.

Installation, Continued

Mounting an actuator to a valve

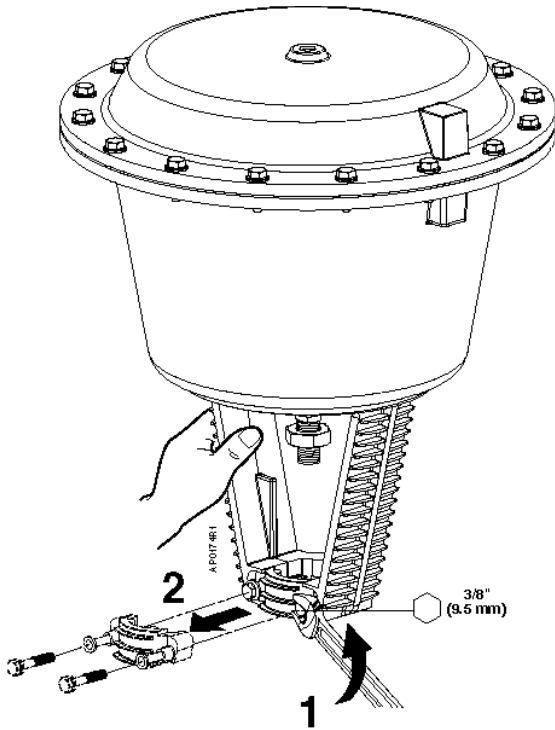

Figure 6.

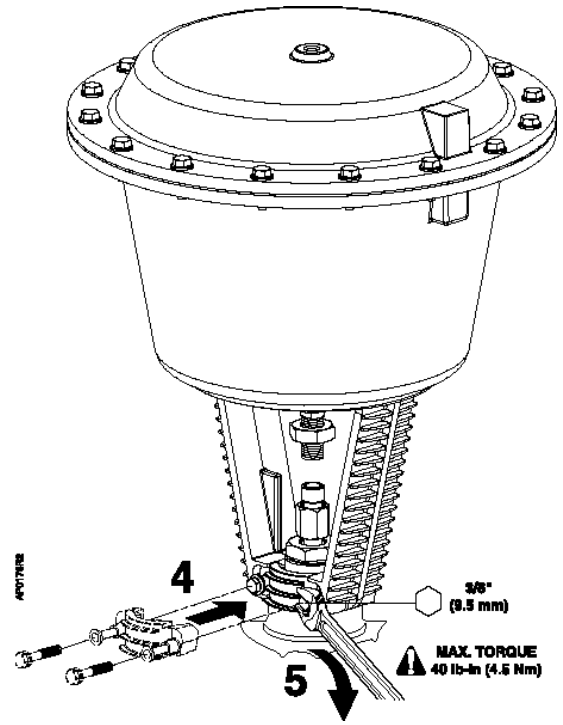

Figure 8.

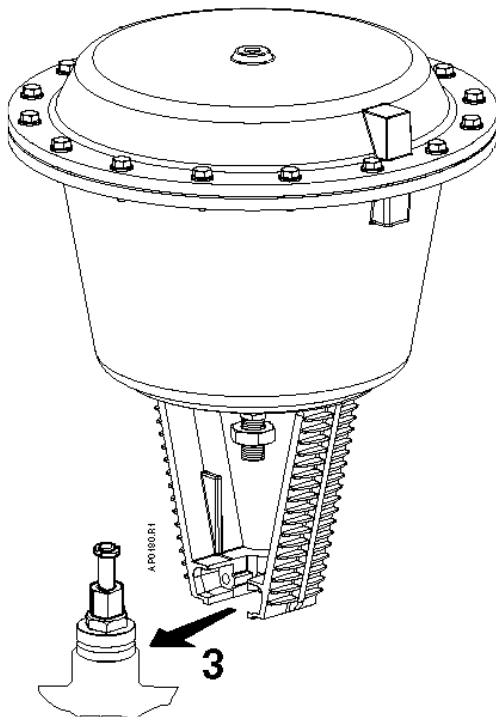

Figure 7.

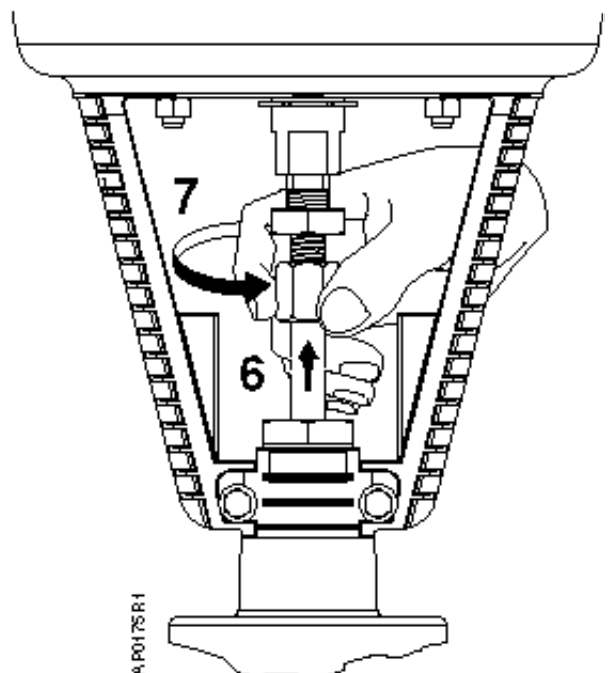

Figure 9.

Installation, Continued

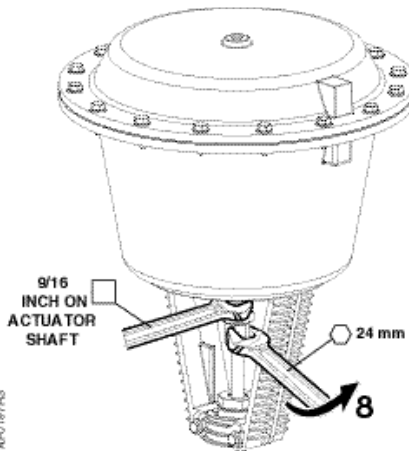

Figure 10.

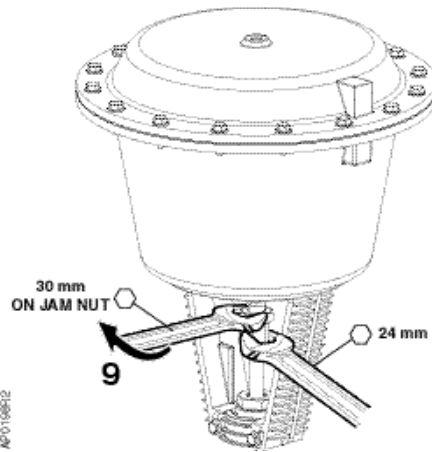

Figure 11.

Spring Adjustment

The top edge of the stem nut indicates the valve stem position. The "0" marking on the actuator yoke indicates stem up position. The "1" mark indicates stem down position. See *Figure 12*.

With the actuator in an upright position and the stem visible as shown in *Figure 12*, use a 1-1/16 inch open-end wrench to turn the adjustment screw.

- **For Normally Open Valves:**
 To increase the start to close pressure, turn the adjustment screw counterclockwise. To decrease, turn the adjustment screw clockwise.
- **For Normally Closed Valves:**
 To increase the start to open pressure, turn the adjustment screw counterclockwise. To decrease, turn the adjustment screw clockwise.

NOTE: As the line pressure differential across the valve increases, the spring span will increase.

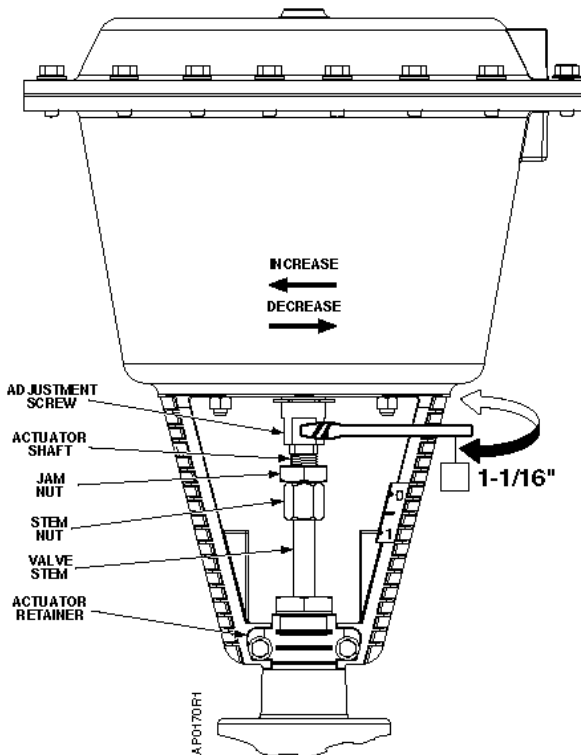

Figure 12. Spring Adjustment.

The installation is now complete.

Reference

Technical Instructions

AP 599-2 Flowrite AP 599 Series
 12-inch Pneumatic Valve Actuator
 155-162P25

Information in this publication is based on current specifications. The company reserves the right to make changes in specifications and models as design improvements are introduced. Flowrite is a registered trademark of Siemens Industry, Inc. Product or company names mentioned herein may be the trademarks of their respective owners. © 2009 Siemens Industry, Inc.