

### SKB/C Electronic Valve Actuator

#### Product Description



The SKB/C actuators require a 24 Vac supply signal to control either a 3/4-inch (20 mm) or 1-1/2-inch (40 mm) stroke valve. These actuators work with Flowrite™ 599 Series valves with a 3/4-inch (20 mm) stroke (SKB) or a 1-1/2-inch (40 mm) stroke (SKC).

#### Product Numbers

SKBx 3/4-inch (20 mm) stroke

SKCx 1-1/2-inch (40 mm) stroke

#### Warning/Caution Notations

<b>WARNING:</b>		Personal injury or loss of life may occur if you do not follow a procedure as specified.
<b>CAUTION:</b>		Equipment damage, or loss of data may occur you do not follow a procedure as specified.

#### Required Tools

- 24 mm open-end wrench
- 3/8-inch open-end wrench
- No. 1 Phillips or flat-blade screwdriver
- Small adjustable wrench

#### Expected Installation Time

20 minutes for factory-installed actuator

46 minutes for field replacement of actuator

#### Prerequisites



**WARNING:**

If mounting the actuator to a valve already in line, either close the shut-off valves in the piping (upstream first, then downstream) or switch off the pump to allow the differential and static pressure in the valve to drop.



**CAUTION:**

Do not damage or scratch the polished surface of the valve stem.

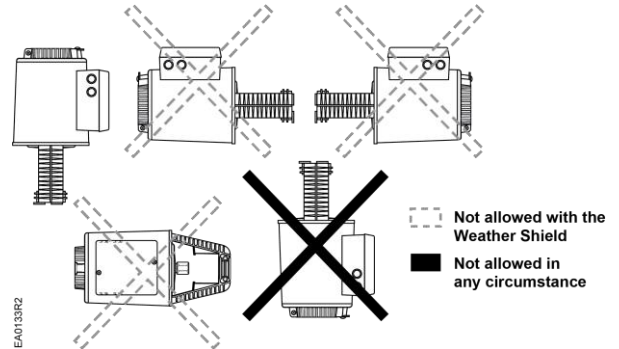

**Figure 1. Acceptable Mounting Positions.**

The vertical position is required for mounting and is the only position for the NEMA Type 3R rating with the Weather Shield.

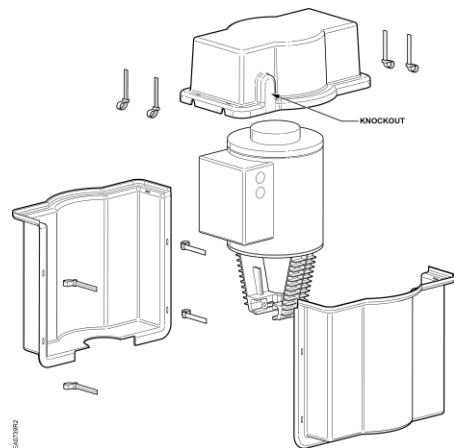

**Figure 2. SKB/C Weather Shield.**

#### Using the Weather Shield

The SKB/C actuator is UL listed to meet NEMA Type 3R requirements (a degree of protection against rain, sleet, and damage from external ice formation) when installed with the Weather Shield, product number 599-10065, and outdoor-rated conduit fittings. The SKB/C must be in the vertical position. Complete instructions for the mounting of the Weather Shield are included with that product. See Figure 31 for Weather Shield dimensions.

## Installation

If you are mounting an actuator on a new valve, begin with the instructions in Figure 6.

### Removing the Actuator from the Valve

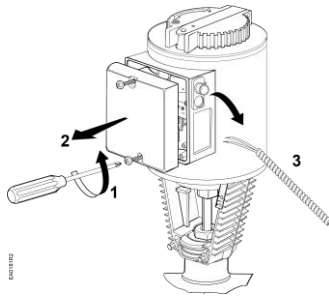

Figure 3.

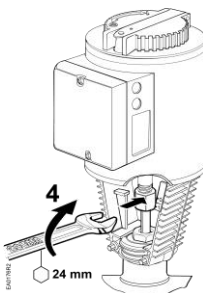

Figure 4.

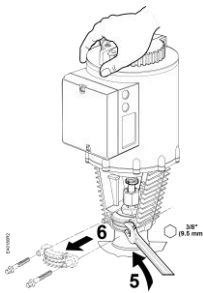

Figure 5.

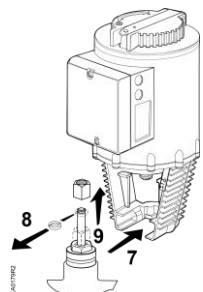

Figure 6.

### Preparation for Mounting an Actuator on a Valve.

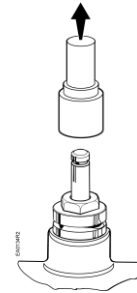

Figure 7. Preparing a New Valve.

**NOTE:** Install the stem heating element (P/N ASZ6.6), if used, before proceeding to Figure 8.

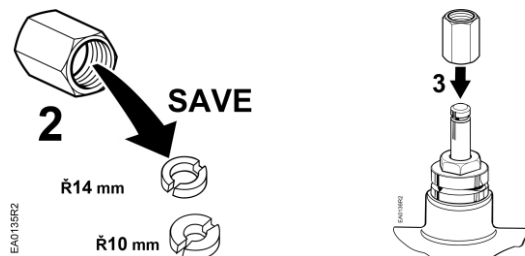
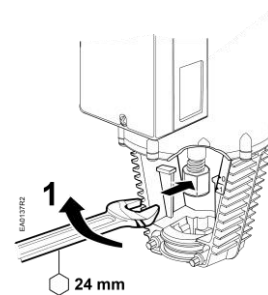

Figure 8.

**NOTE:** Place the narrow opening end of the nut over the valve stem first.

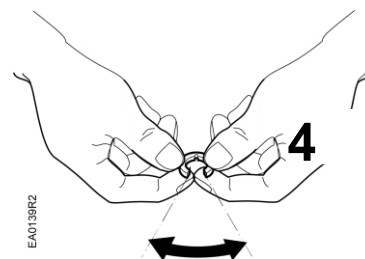

Figure 9.

**NOTE:** Be careful not to break the washer.

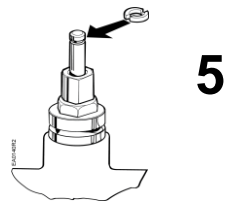

Figure 10.

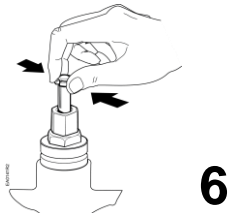

Figure 11.

**Mounting an Actuator to a Valve**

**NOTE:** Install the stem heating element, (P/N ASZ6.6), if used, before proceeding.

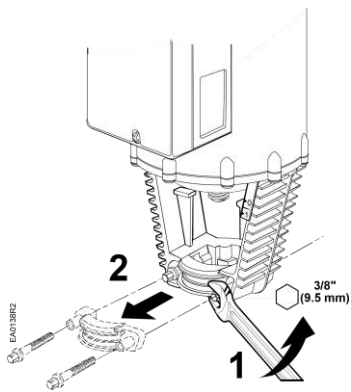

Figure 12.

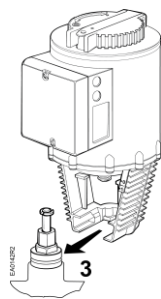

Figure 13.

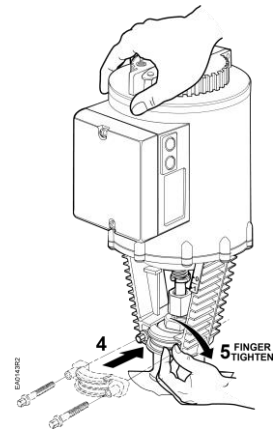

Figure 14.

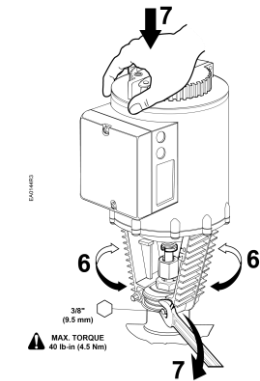

Figure 15.

Position the actuator to accommodate the wiring. Hold the actuator in place while tightening the retaining clamp.

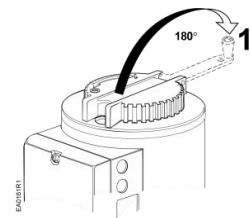

Figure 16.

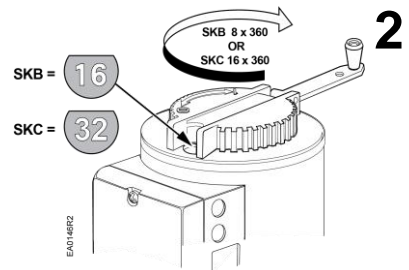

Figure 17.

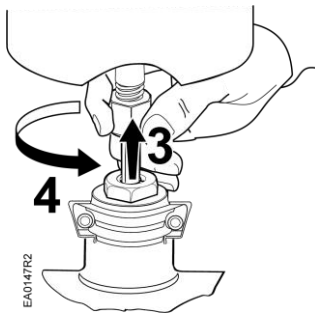

Figure 18.

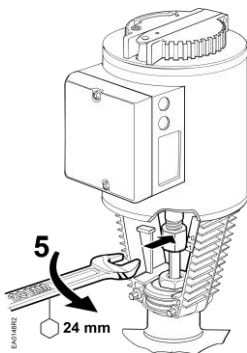

Figure 19.

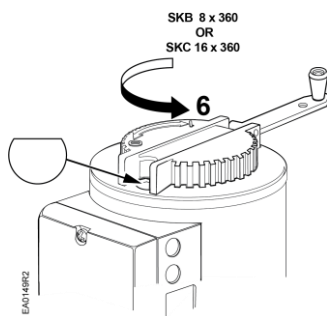

Figure 20.

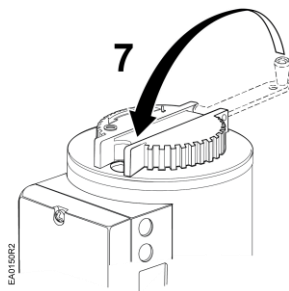

Figure 21.

## Wiring



**CAUTION:** Use care when removing the knockout. Do not damage the circuit board. If possible, use the top knockout position.

Do not use autotransformers. Use earth ground isolating step-down Class 2 transformers.

Determine supply transformer rating by summing total VA of all actuators used. The maximum rating for a Class 2 step-down transformer is 100 VA.

Actuator	Power Consumption	Actuators Per Class 2 Supply Circuit* (80% of transformer VA)
SKB62U	17 VA	4
SKC62U	28 VA	2
SKB82.50U	10 VA	8
SKB82.51U	15 VA	5
SKC82.60U	19 VA	4
SKC82.61U	20 VA	4

\* Operating more actuators requires additional transformers or separate 100 VA power supplies.

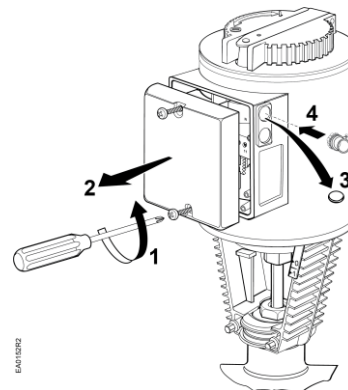

Figure 22.

- Wiring for SKB/C62U is shown in Figure 23 and Figure 24.
- Wiring for SKB/C82...U is shown in Figure 25, Figure 26, and Figure 27.
- The position output signal **U** will switch from 0 to 10 Vdc to 4 to 20 mA when a 4 to 20 mA input signal is selected and used on the terminal.

**SKB/C62U**

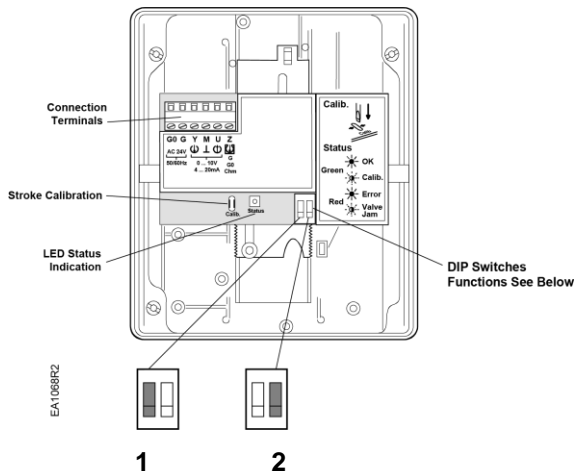

Figure 23. SKB/C62U.

DIP Switches	1 Selection of Control Signal	2 Selection of Flow Characteristic
ON	4 to 20 mA	Modified*
OFF (Factory Setting)	0 to 10 Vdc	Default

\*Changing the default setting will modify an equal percentage valve to a linear flow characteristic. When set to default, the flow characteristic is determined by the valve body.

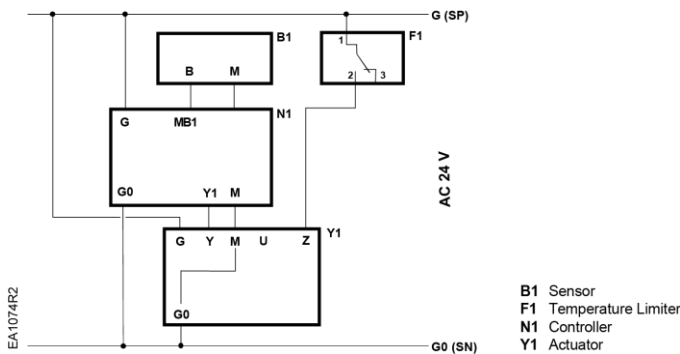

Figure 24.

**Connecting Terminals**

24 Vac	
G	System Potential (SP)
G0	System Neutral (SN)
Y	Control Input 0 to 10 Vdc or 4 to 20 mA (DIP switch selectable)
Z	Override Input (See <i>Technical Instructions 155-163P25</i> )
M	Measuring Neutral
U	Position Indicator for 0 to 10 Vdc or 4 to 20 mA .

**Non-Spring Return  
 SKB82.50U, SKC82.60U**

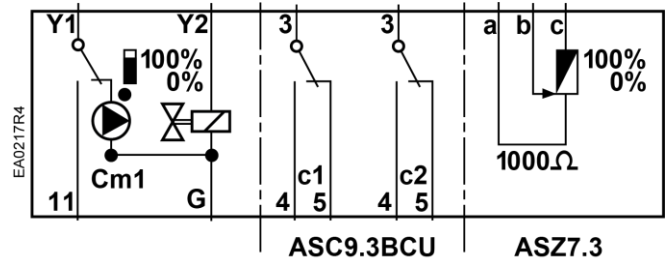
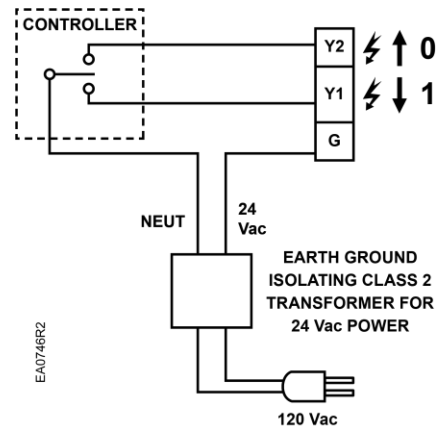

Figure 25. Non-Spring Return.

**Connecting Terminals**

G	System Potential 24 Vac (+)
Y1	Downward movement of coupling piece (0 to 1)
Y2	Upward movement of coupling piece (1 to 0)
Cm1	Limit switch for 100% stroke
c1	ASC9.3BCU double auxiliary switch
c2	ASC9.3BCU double auxiliary switch
1000 Ω	ASZ7.3 potentiometer

The diagram shows all possible connections. How many and which are used depend on the application.

### Spring Return SKB82.51U and SKC82.61U

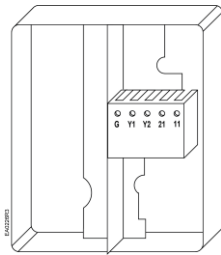

Figure 26.

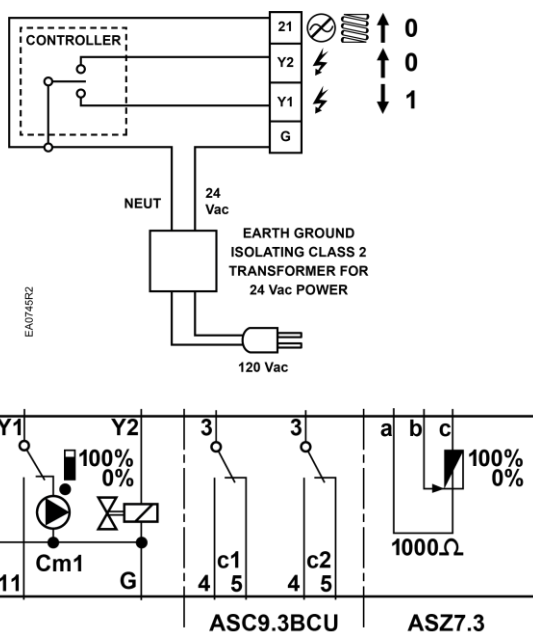

Figure 27. Spring Return.

#### Connecting Terminals

G	System Potential 24 Vac (+)
21	System Neutral (SN)
Y1	Downward movement of coupling piece (0 to 1)
Y2	Upward movement of coupling piece (1 to 0)
Cm1	Limit switch for 100% stroke
c1	ASC9.3BCU double auxiliary switch
c2	ASC9.3BCU double auxiliary switch
1000 Ω	ASZ7.3 potentiometer

#### Start-up

Check the wiring for proper connections.

Consult Technical Instructions for detailed commissioning instructions.

#### Stroke Calibration

To determine the stroke positions 0% and 100% in the valve, calibration is required when the valve/actuator are commissioned for the first time.

For this purpose, the actuator must be mechanically connected to a valve and must have a supply voltage of 24 Vac. Repeat the calibration procedure as often as necessary. See *Flowrite 599 Series SKB/C Electronic Valve Actuator Proportional Control Technical Instructions 155-163P25* for details.

#### Normally Closed Valve

Actuator pressure cylinder moves:

- Outward (0 to 1): Valve opens.
- Inward (1 to 0): Valve closes.

#### Normally Open Valve

Actuator pressure cylinder moves:

- Outward (0 to 1): Valve closes.
- Inward (1 to 0): Valve opens.

#### Three-Way Valve

Actuator pressure cylinder moves:

- Outward: Valve opens between port NC and C.
- Inward: Valve opens between ports NO and C.

**NOTE:** The valve body assembly determines the complete assembly action.

#### Reference

Technical Instruction	Document Number
Flowrite EA599 Series SKB/C Electronic Valve Actuator Proportional Control	155-163P25
Flowrite EA599 Series SKB/C Electronic Valve Actuator 3-position (Floating) Control	155-171P25

### Manual Operation

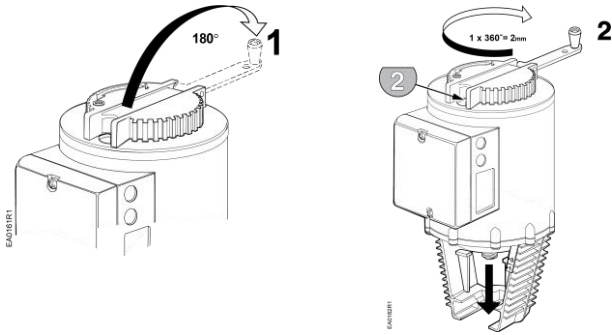

Figure 28. Manual Operation.

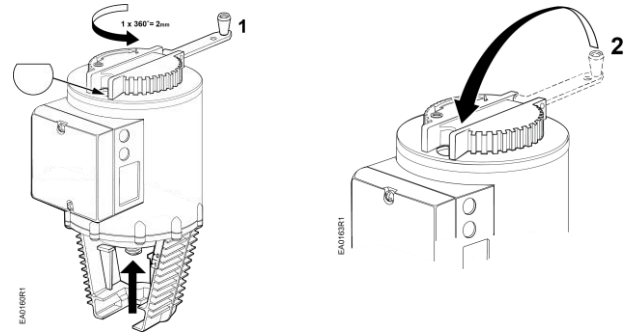

Figure 29. Return to Automatic Operation.

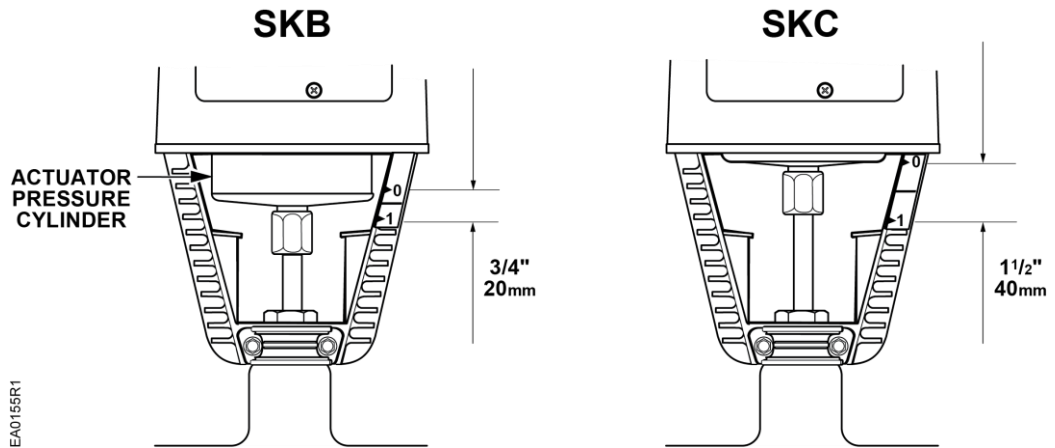

Figure 30. Valve Stem Travel Indication.

## Dimensions

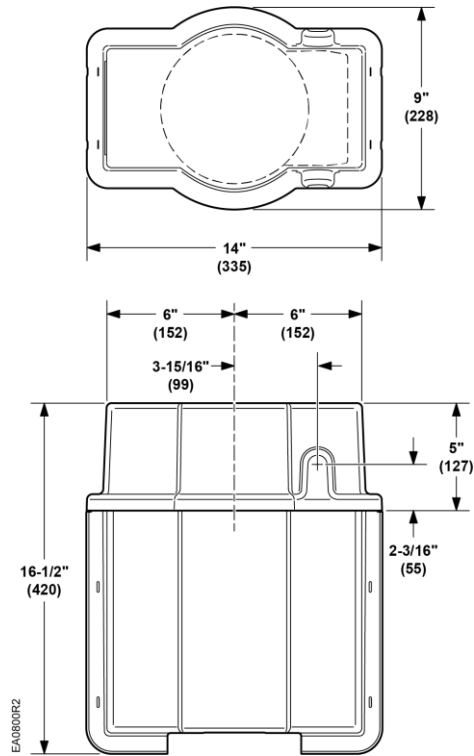

Figure 31. SKB\C Weather Shield, 599-10065 in Inches (mm).



## Dimensions, continued



### CAUTION:

Be careful when removing the knockout. Do not damage the circuit board. Use the top knockout position.

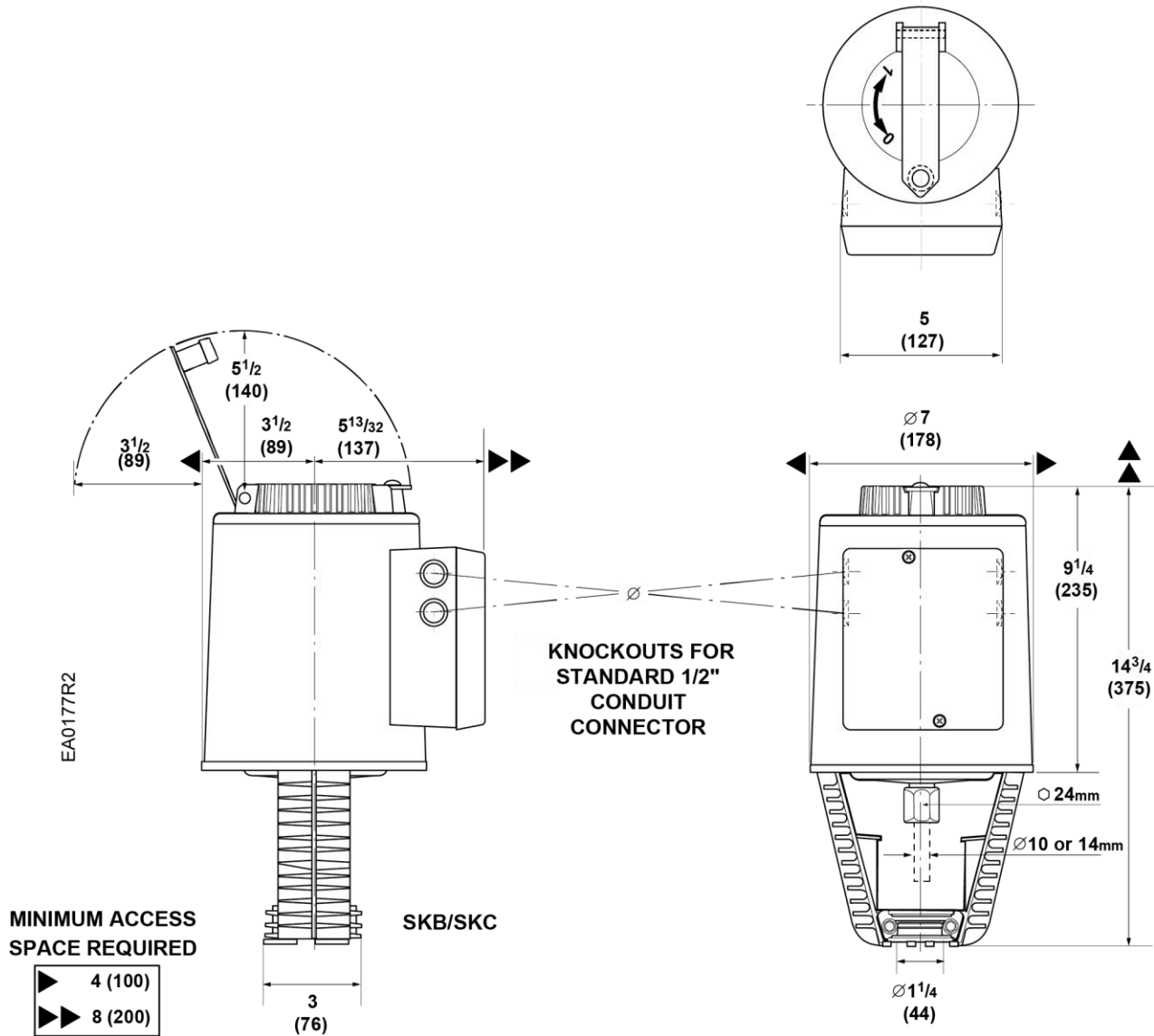

Figure 32. SKB/SKC Dimensions in Inches (mm).

Information in this publication is based on current specifications. The company reserves the right to make changes in specifications and models as design improvements are introduced. Other product or company names mentioned herein may be the trademarks of their respective owners. Flowrite is a trademark of Siemens Industry, Inc. © 2018 Siemens Industry, Inc.