



## SSB Series Electronic Valve Actuator

### Product Description

The SSB actuator requires a 24 Vac, Class 2, 0 to 10 Vdc supply signal or floating control signal to control Powermite 599 MZ Series zone control valves with 7/32-inch (5.5 mm) stroke.

### Installation Conventions

<b>WARNING:</b>		Personal injury/loss of life may occur if a procedure is not performed as specified.
<b>CAUTION:</b>		Equipment damage, or loss of data may occur if the user does not follow procedure as specified.

### Product Number

SSB81U      3-position (floating) control

### Contents

- 1 – actuator
- 1– terminal plug
- 1– terminal connector.

### Required Tools

- Small flat blade screwdriver
- Wire stripper

### Estimated Installation Time

20 minutes

### Prerequisites



#### WARNINGS:

- If mounting the actuator to a valve already in line, either close the shut-off valves in the piping (upstream first, then downstream) or switch off the pump to allow the differential pressure in the valve to drop.
- Disconnect the controller power before replacing the actuator.

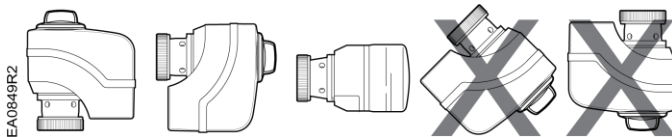

Figure 1. Acceptable Mounting Positions.

**NOTE:** The vertical position is recommended for mounting.

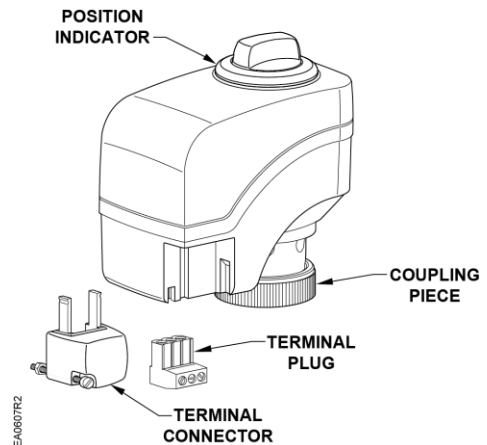

Figure 2. SSB Actuator.

### Instructions

If you are mounting an actuator on a new valve, begin with the instructions *Mounting an Actuator to a Valve*.

#### Removing the Actuator from a Valve

1. Loosen the terminal connector with a flat blade screwdriver.
2. Remove the terminal connector and the terminal plug from the actuator.
3. Remove the terminal plug from the connector and save.
4. Loosen the coupling piece.
5. Remove the actuator from the valve.

#### Mounting an Actuator to a Valve

1. If you are attaching the actuator to a new valve, remove the protective plastic cap from the valve stem.
2. Turn the manual-positioning knob on the top of the actuator to **0**.
3. Attach the wires to the terminal plug.
4. Insert the terminal plug into the terminal connector. See Figure 3.

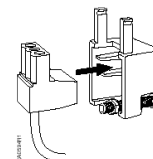

Figure 3.

- Place the terminal connector and plug into the actuator, fitting the nut into the recess in the bottom of the actuator. See Figure 4.

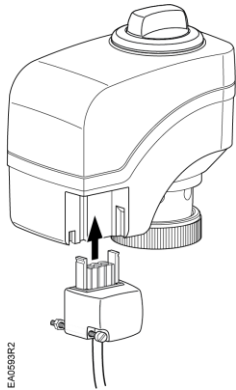

Figure 4.

- Tighten the screw to hold the connector in place. See Figure 5.

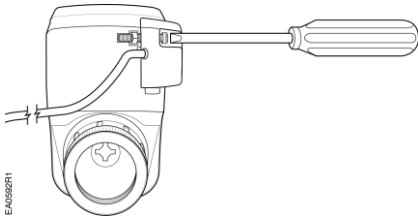

Figure 5.

- Place the actuator on the valve and firmly hand-tighten the coupling. See Figure 6.

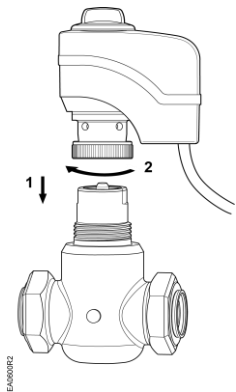

Figure 6.

The installation is complete

## Wiring

- All wiring must conform to NEC and local codes and regulations.
- Use earth ground isolating step-down Class 2 transformers. Do not use autotransformers.
- Determine the supply transformer rating by summing total VA of all actuators used. The maximum rating for Class 2 step-down transformer is 100 VA.

- It is recommended that one transformer power no more than 10 actuators.



**WARNING:**

Terminal connection G is 24 Vac HOT, not ground.



**CAUTION:**

G must be properly wired for correct function and full life of the actuator.

## SSB81U

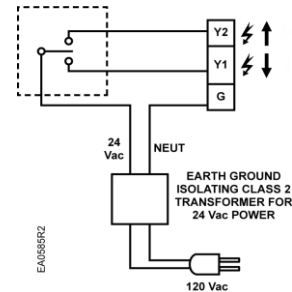

Figure 7. Wiring diagram for SSB81U.

G	24 Vac operating voltage
Y1	Outward movement of the output shaft
Y2	Inward movement of the output shaft

## References

### Technical Instructions

EA 599-13  
 Powermite 599 Series SSB Electronic Valve Actuator  
 3-position Control

### Document Number

155-195P25

## Manual Override

For manual positioning, turn the manual override knob in the center of the position indicator. See Figure 9. Turn the wrench clockwise to extend the actuator spindle. The actuator will maintain its position until power is provided or restored.

### NOTE: For SSB61U

If an override is performed while the power supply is connected, the actuator will not track accurately when the control signal is applied. A short power off/power on sequence is recommended to recalibrate the actuator.

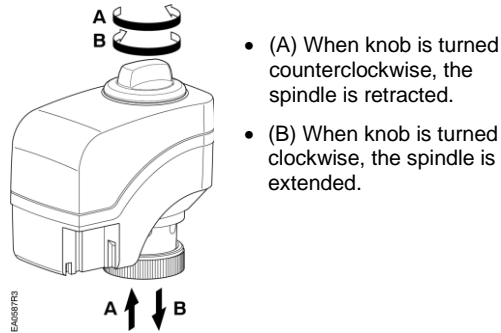

- (A) When knob is turned counterclockwise, the spindle is retracted.
- (B) When knob is turned clockwise, the spindle is extended.

Figure 8.

## Start-up

- Check the wiring and the position indication.
- When the position indicator is on the **1** position the output shaft is extended.
- When the position indicator is in the **0** position, the output shaft is retracted.

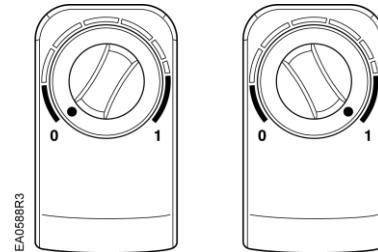

Position indicator at **1**.

Position Indicator at **0**.

The **0** and **1** position markings are for reference only, and not intended for stroke measurement.

## Troubleshooting

Check the wiring for the proper connections.

## Dimensions

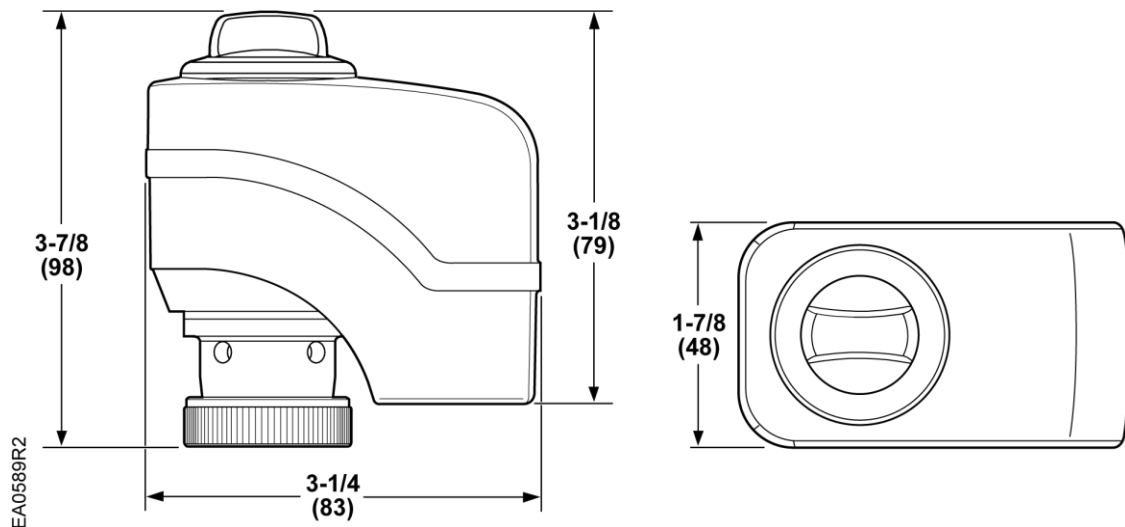

Figure 9. Dimensions shown in inches (millimeters).

## Service envelope

Minimum access space recommended: 8 inches (200 mm) above the actuator, 8 inches (200 mm) beside the terminal plug.

Information in this publication is based on current specifications. The company reserves the right to make changes in specifications and models as design improvements are introduced. Product or company names mentioned herein may be the trademarks of their respective owners.

© 2009-2022 Siemens Industry, Inc.