

SKB/C62UA Series Electronic Valve Actuator with Advanced Features



Product Description

The SKB/C62UA valve actuators require a 24 Vac supply and receive a 0 to 10 Vdc or 4 to 20 mA control signal to proportionally control a valve. These actuators work with Flowrite™ 599 Series valves or other manufacturer's valves with the appropriate Universal Valve Linkage Kit.

Product Numbers

SKB62UA 3/4-inch (20 mm) stroke
 SKC62UA 1-1/2-inch (40 mm) stroke

Warning/Caution Notations

WARNING:		Personal injury or loss of life may occur if you do not follow procedure as specified.
CAUTION:		Equipment damage or loss of data may occur if you do not follow a procedure as specified.

Required Tools

- 24 mm open-end wrench
- 3/8-inch open-end wrench
- No. 1 Phillips or flat-blade screwdriver
- Small adjustable wrench

Expected Installation Time

20 minutes for factory installed actuator
 46 minutes for field replacement of actuator

Prerequisites



WARNING:

If mounting the actuator to a valve already in line, either close the shut-off valves in the piping (upstream first, then downstream) or switch off the pump to allow the differential and static pressure in the valve to drop.



CAUTION:

Do not damage or scratch the polished surface of the valve stem.

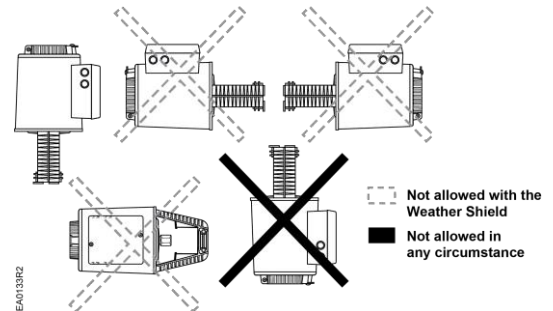

Figure 1. Acceptable Mounting Positions.

The vertical position is recommended for mounting and the only position for the NEMA Type 3R rating with the Weather Shield.

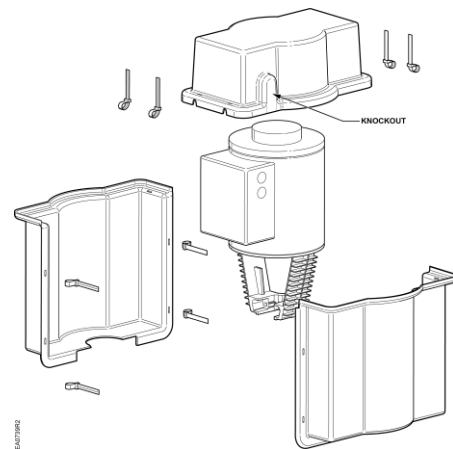

Figure 2. SKB/C Weather Shield.

Using the Weather Shield

The SKB/C62UA actuator is UL listed to meet NEMA Type 3R requirements (a degree of protection against rain, sleet, and damage from external ice formation) when installed with the Weather Shield, product number 599-10065, and outdoor-rated conduit fittings.

The SKB/C62UA must be in the vertical position. Complete instructions for the mounting of the Weather Shield are included with that product. See Figure 28 for Weather Shield dimensions.

Installation

If you are mounting an actuator on a new valve, begin with the instructions in Figure 7.

Removing the Actuator from the Valve

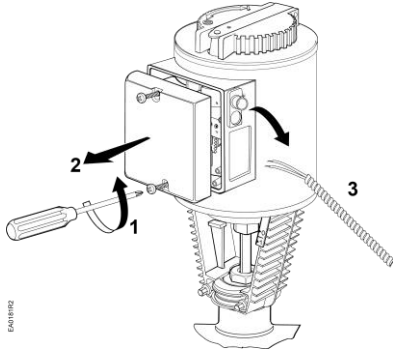

Figure 3.

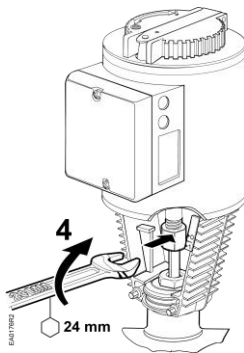

Figure 4.

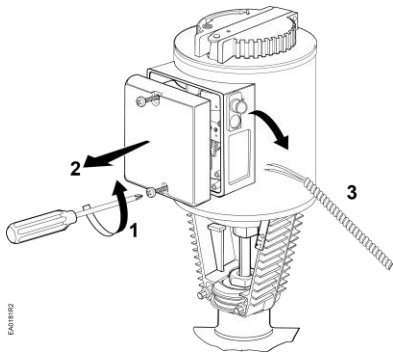

Figure 5.

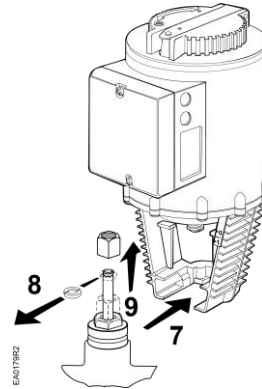

Figure 6.

Preparation for Mounting an Actuator on a Valve.

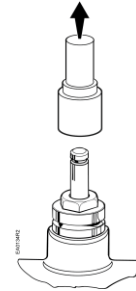

Figure 7. Preparing a New Valve.

NOTE: Install the stem heating element (P/N ASZ6.6), if used, before proceeding to Figure 9.

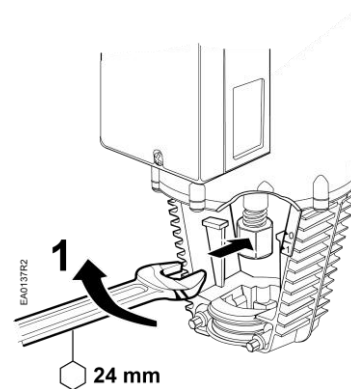

Figure 8.

Preparation for Mounting an Actuator on a Valve, Continued

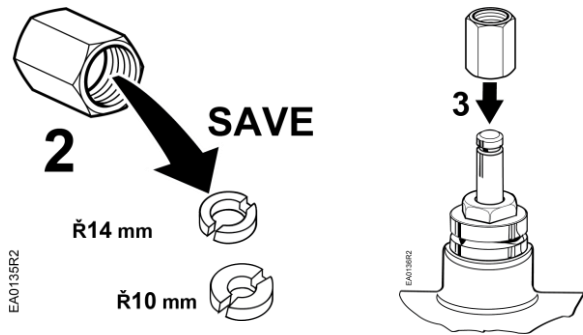

Figure 9.

NOTE: Place the narrow opening end of the nut over the valve stem first.

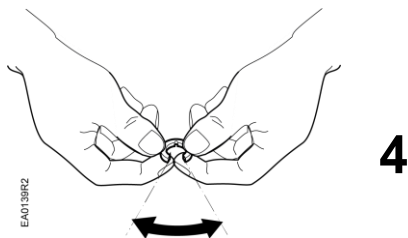

Figure 10.

NOTE: Be careful not to break the washer.

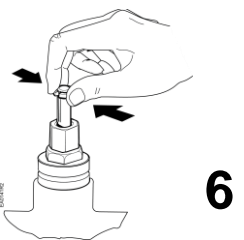
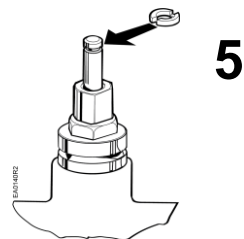

Figure 11.

Mounting an Actuator to a Valve

NOTE: Install the stem heating element, (P/N ASZ6.6), if used, before proceeding.

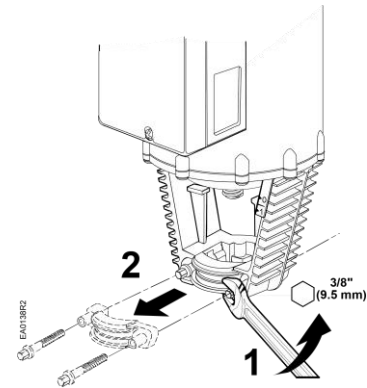

Figure 12.

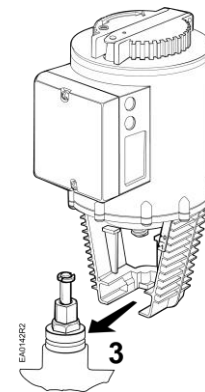

Figure 13.

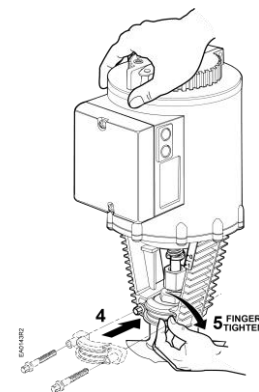

Figure 14.

Mounting an Actuator to a Valve, Continued

Position the actuator to accommodate the wiring. Hold the actuator in place while tightening the retaining clamp. See Figure 15.

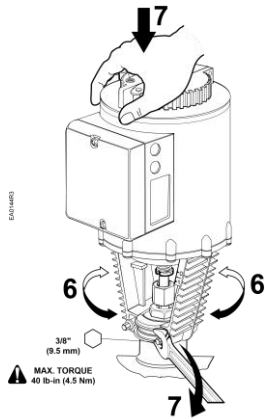

Figure 15.

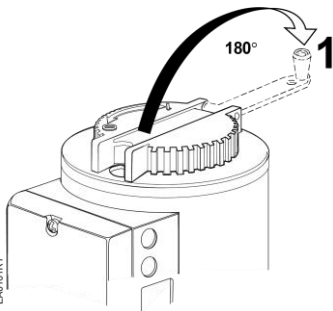

Figure 16.

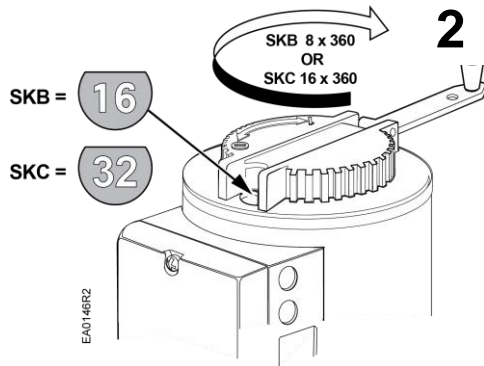

Figure 17.

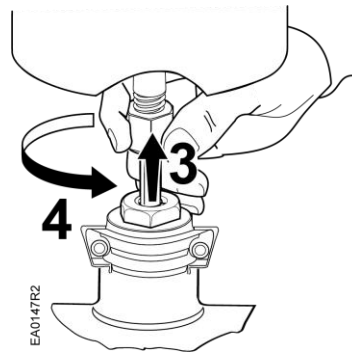

Figure 18.

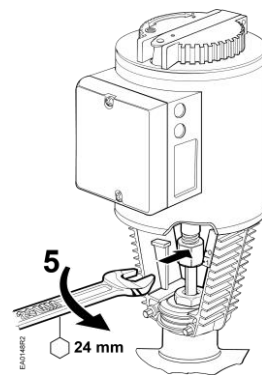

Figure 19.

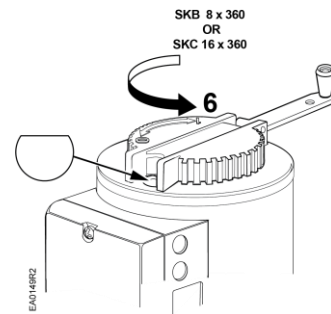

Figure 20.

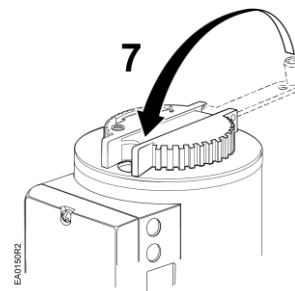

Figure 21.

Wiring



CAUTION:

Use care when removing the knockout. Do not damage the circuit board. Use the top knockout position.

Do not use autotransformers. Use earth ground isolating step-down Class 2 transformers.

Determine supply transformer rating by summing the total VA of all actuators used. The maximum rating for a Class 2 step-down transformer is 100 VA.

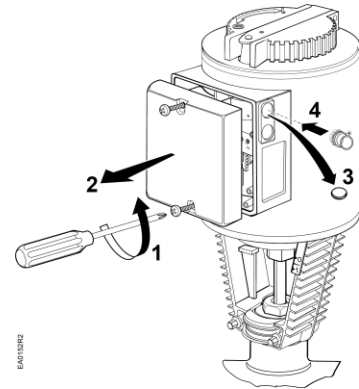

Figure 22.

Actuator	Power Consumption	Actuators per Class 2 Supply Circuit* (80% of transformer VA)
SKB62UA	17 VA	4
SKC62UA	28 VA	2

Wiring for SKB/C62UA is shown in Figure 23 and Figure 24.

*Operating more actuators requires additional transformers or separate 100 VA power supplies.

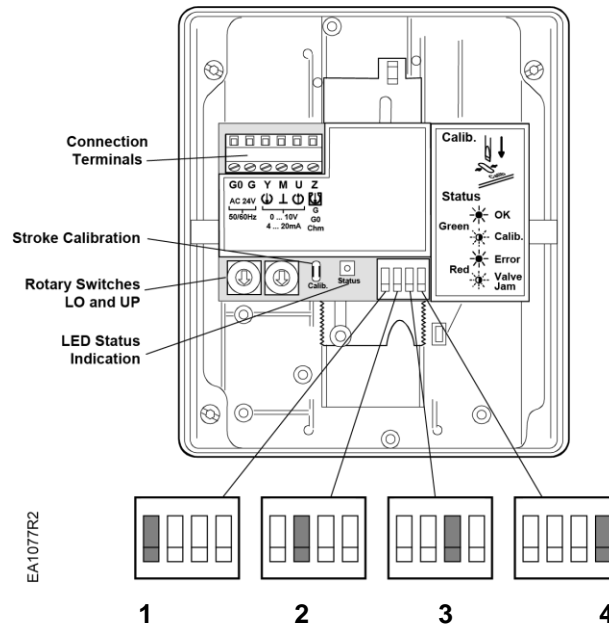

Figure 23. SKB/C62UA.

DIP Switches (From Left to Right)	1 Select Direction of Operation	2 Sequence Control or Stroke Limit Control	3 Selection of Control Signal	4 Selection of Flow Characteristic
ON	Reverse-acting	Sequence control	4 to 20 mA	Modified*
OFF (Factory Settings)	Direct-acting	Stroke limit control	0 to 10 Vdc	Default

*Changing the default setting will modify an equal percentage valve to a linear flow characteristic. When set to Default, the flow characteristic is determined by the valve body.

Wiring

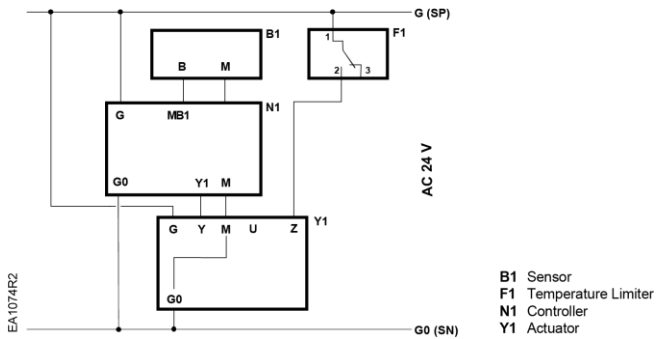

Figure 24. Wiring Diagram.

Connecting Terminals

24 Vac	
G	System Potential (SP)
G0	System Neutral (SN)
Y	Control Input: 0 to 10 Vdc or 4 to 20 mA (DIP switch selectable)
Z	Override Input (See <i>Technical Instructions 155-717</i>)
M	Measuring Neutral
U	Position Indicator: 0 to 10 Vdc or 4 to 20 mA

The position output signal U will switch from 0 to 10 Vdc to 4 to 20 mA when a 4 to 20 mA input signal is selected and used on the terminal.

Start-Up

- Check the wiring for proper connections.
- Consult the *Flowrite 599 Series SKB/C/D 62UA Series Electronic Valve Actuator 24 Vac Proportional Control Advanced Features Technical Instructions 155-717* for detailed commissioning instructions.

Stroke Calibration

To determine the stroke positions 0 and 100% in the valve, calibration is required when the valve/actuator are commissioned for the first time.

The actuator must be mechanically connected to a valve and must have a supply voltage of 24 Vac. The calibration procedure can be repeated as often as necessary.

To initiate the calibration procedure, short circuit the contacts inside the slot located on the printed circuit board (with a screwdriver).

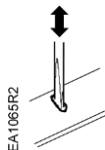

Automatic calibration proceeds as follows:

- Actuator runs to the 0 stroke position (1) the green LED flashes .
- Actuator then runs to the 100% stroke position (2) the green LED flashes.

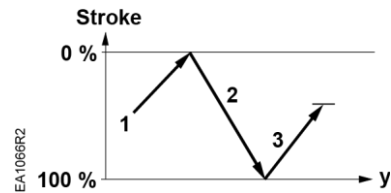

- Measured values are stored in the EPROM.
- The actuator now moves to the position defined by control signal Y or Z (3), and the green LED now glows steady (normal operation)
- Throughout this procedure, output U is inactive, meaning the values only represent actual positions when the green LED stops flashing and remains on continually.

Table 1. LED Status.

LED	Display	Function	Action
Green	ON	Normal Operation	Automatic operation
	Flashing	Stroke calibration In Progress	Wait for calibration to be completed (LED stops flashing)
Red	ON	Faulty stroke calibration	- Check mounting - Restart stroke calibration (by short-circuiting calibration slot)
	Flashing	Internal Error	- Replace electronics
	OFF	Inner valve jammed	Check the valve
	OFF	<ul style="list-style-type: none"> • No power supply • Faulty electronics 	-Check mains -Replace electronics



CAUTION:

Before starting calibration, be sure that the manual adjuster is set to **Automatic** to register the actuator values.

Stroke Calibration, continued

Normally Closed Valve

Actuator pressure cylinder moves:

- Outward (0 to 1): Valve opens.
- Inward (1 to 0): Valve closes.

Normally Open Valve

Actuator pressure cylinder moves:

- Outward (0 to 1): Valve closes.
- Inward (1 to 0): Valve opens.

Three Way Valve

Actuator pressure cylinder moves:

- Outward: Valve opens between port NC and C.
- Inward: Valve opens between ports NO and C.

NOTE: The valve body assembly determines the complete assembly action.

Reference

Technical Instructions

Flowrite™ EA599 Series SKB/C/D 62U
 Series Electronic Valve Actuators 24 Vac
 Proportional Control Advanced Features

**Document
 Number**
 155-717

Manual Operation

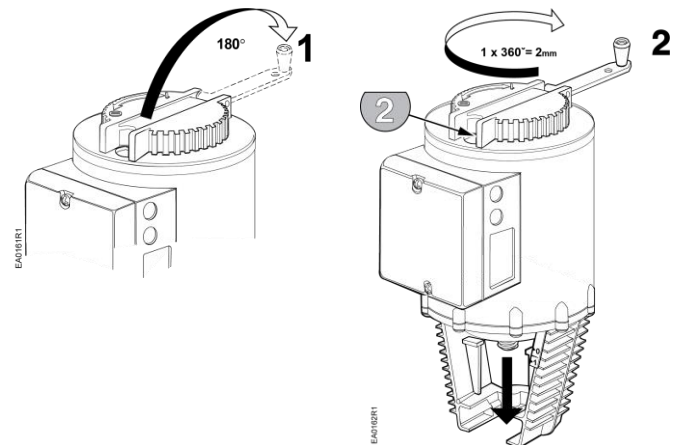

Figure 25. Manual Operation.

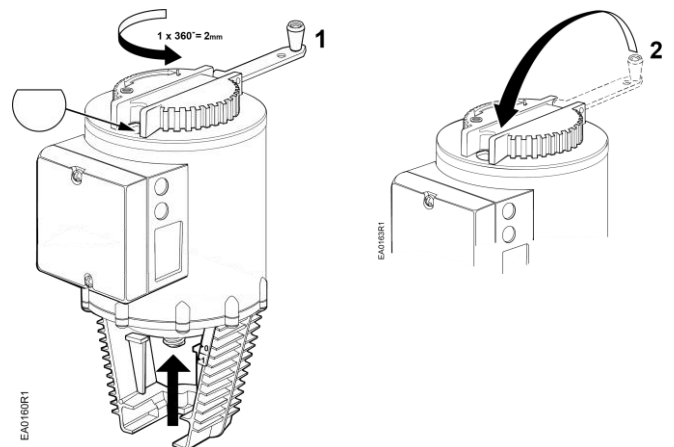

Figure 26. Return to Automatic Operation.

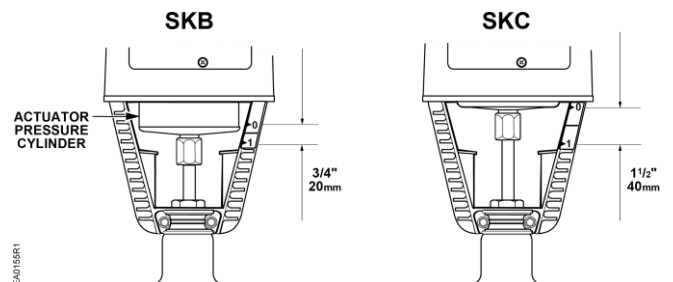

Figure 27. Valve Stem Travel Indication.

Dimensions

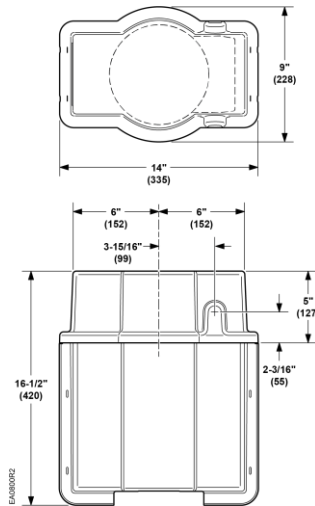

Figure 28. SKB/C Weather Shield, 599-10065 Dimensions in Inches (Millimeters).



CAUTION:

Be careful when removing the knockout. Do not damage the circuit board. Use the top knockout position.

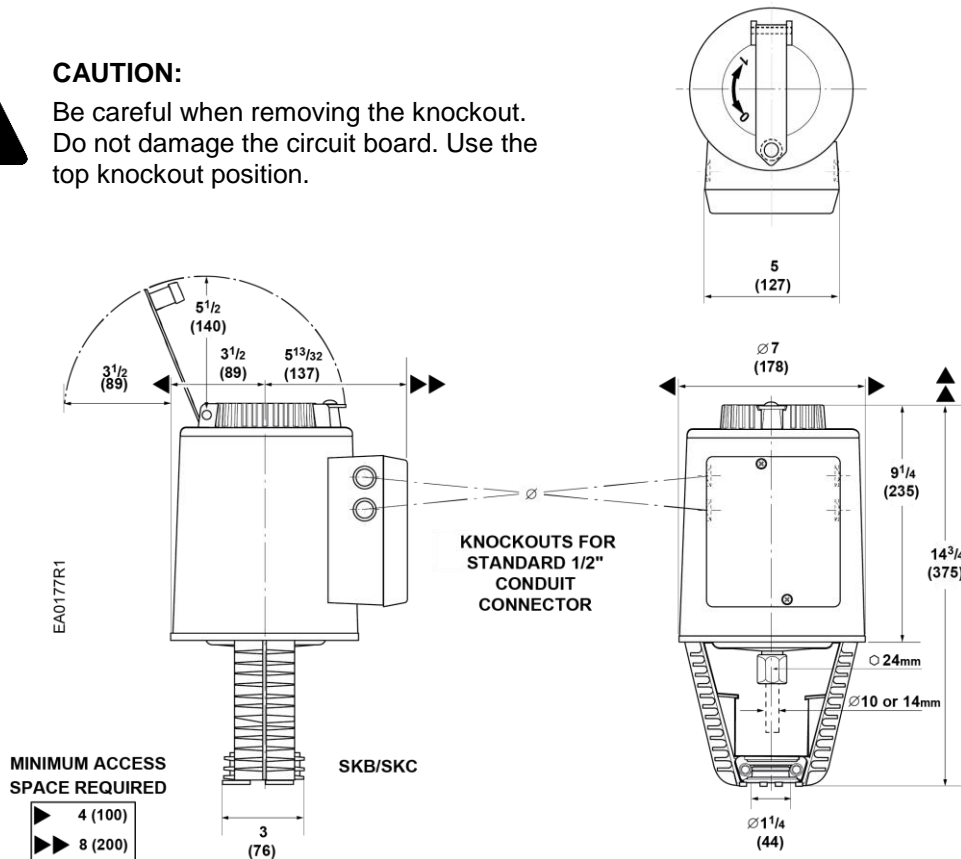

Figure 29. SKB/C62UA Dimensions in Inches (Millimeters).

Information in this publication is based on current specifications. The company reserves the right to make changes in specifications and models as design improvements are introduced. Flowrite is a registered trademark of Siemens Industry, Inc. Product or company names mentioned herein may be the trademarks of their respective owners. © 2018 Siemens Industry, Inc.