

## Surface Mount Temperature Sensor

### Product Description

The Surface Mount Temperature Sensor mounts directly on a pipe inlet and senses the temperature of water in the pipe.

### Product Number

Product Number	Output Signal
QAD2030U	10k WNTC Type II Thermistor
QAD2032U	10k WNTC Type III Thermistor
QAD2012U	1k WPt RTD (385a)
QAD2020U	1k W @ 32°F Ni RTD
QAD2021U	1k W @ 70°F Ni RTD
536-780	4 to 20 mA (30°F to 250°F)
544-089	1k WPt RTD (375a)

### Contents

Description	Quantity
Sensor	1
Mounting Kit:	
· Junction box	1
· Strap	1
· Wire nuts	2
· No. 20 stretch tape	1 roll

**NOTE:** 536-780 also includes 4 to 20 mA transmitter and two additional wire nuts.

### Required Tools

- Wire cutters
- Knife
- Duct tape
- Wire brush, sandpaper or other abrasive tool
- Medium flat-blade screwdriver

### Expected Installation Time

13 minutes

### Prerequisite

If the pipe is not insulated, a 12-inch to 18-inch (30 cm to 46 cm) piece of insulation will be needed to ensure an accurate temperature reading. The insulation should be at least one-inch (25 mm) thick.

### Installation

**NOTE:** To ensure accuracy, the sensor must be mounted under insulation, away from drafts. Do not cut any wire from the sensor.

1. If the pipe is insulated, remove a portion of the insulation by making two cuts around the circumference of the pipe (between 6 inches and 12 inches [15 cm and 30 cm] apart).
2. Make a third cut perpendicular to the first two cuts so that the insulation can be removed in one piece. See Figure 1. **Save this piece.**

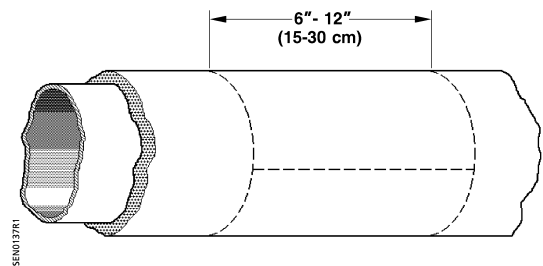
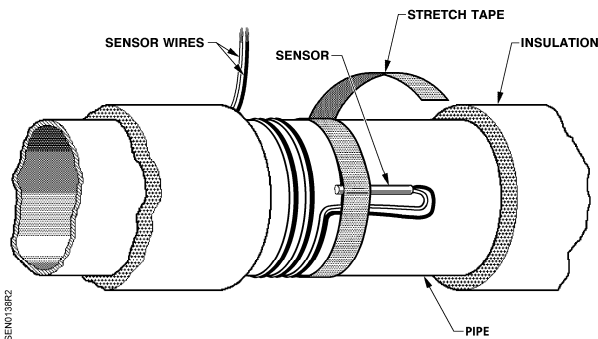

Figure 1. Cutting the Insulation.

## Installation, Continued

- Using an abrasive tool, clean the surface of the pipe where the sensor is to be mounted to ensure good contact with the pipe. See Figure 2.



**Figure 2. Pipe Temperature Sensor.**

- Bend the sensor wires back along the pipe next to the sensor for strain relief. See Figure 2.
- Secure the sensor to the pipe with 1-1/2 to three wraps of the stretch tape provided. Stretch the tape about 25% as you wrap it around the pipe. See Figure 2.
- Wrap the excess sensor wires around the pipe and secure with the stretch tape or duct tape. See Figure 2.
- Replace the insulation removed in Step 1, and secure it to the pipe with duct tape.

**NOTE:** If the pipe is not insulated, wrap a piece of insulation around the sensor and the pipe (see *Prerequisites*). The insulation should be secured to the pipe using duct tape to ensure accuracy.

## Wiring

- Position the junction box on top of the pipe insulation and feed the sensor wires into it from the bottom of the box. The box should be positioned so that the sensor wires come straight up into the junction box from the seam in the reinstalled insulation.

- Thread the strap through the junction box and attach the junction box to the pipe. See Figure 3.

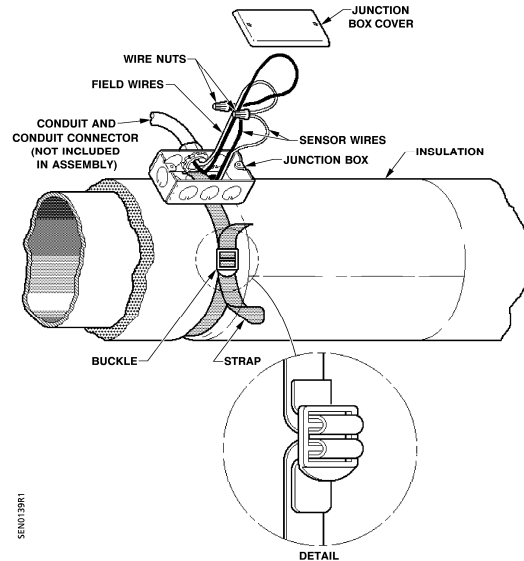

**Figure 3. Attaching the Junction Box and Connecting the Sensor Wires.**

- Connect the electrical conduit, with the field wiring, to the junction box.
- Using two of the wire nuts provided, connect the sensor wires to the field wires. See Figure 3.
- Put all the excess wire into the junction box and install the cover on the box.
- Connect the field wires to the applicable controller. See Figure 4.

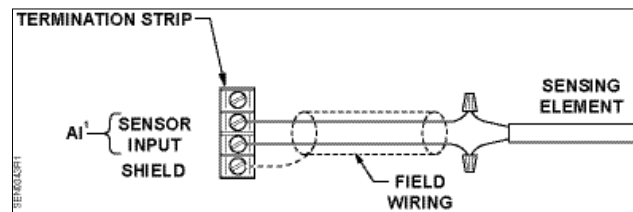

**Figure 4. Typical Sensor Connection.**

**NOTE:** Configure the analog input (AI) point for sensor input.

7. **For 536-780 only**, Connect the wires from the sensor to the appropriate RTD leads of the transmitter with wire nuts. Connect the field wiring to the transmitter. The positive (+) 26V supply lead goes to the **PWR** wire of the transmitter, and the negative signal lead goes to the **SIG** wire. See Figure 5.

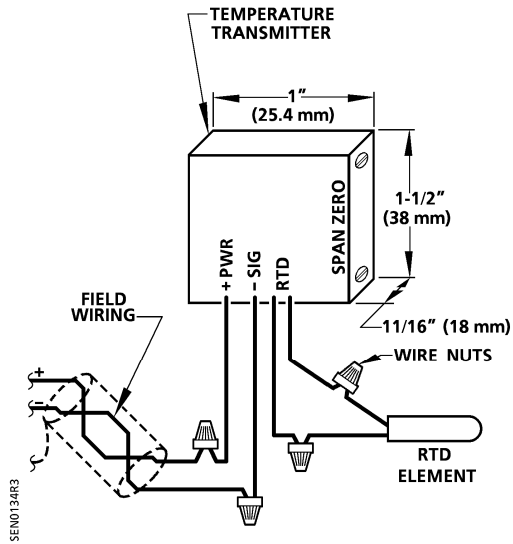

Figure 5. 536-780 (4 to 20 mA Output) Only.

The installation is now complete.

Information in this publication is based on current specifications. The company reserves the right to make changes in specifications and models as design improvements are introduced. Product or company names mentioned herein may be the trademarks of their respective owners. © 2017 Siemens Industry, Inc.