

## Immersion Well Temperature Sensor

### Product Description

The Immersion Well Temperature Sensor provides a temperature input to a controller. It threads into a coupling on a piping system.

### Contents

- Immersion well
- Sensing element
- Pulling elbow for wiring connections

### Product Numbers

Product Number	Sensing Element
QAE2030.XXX	10K $\Omega$ NTC Type II
QAE2032.XXX	10K $\Omega$ NTC Type III
QAE2012.XXX	1K $\Omega$ Pt (385 $\alpha$ )
QAE2020.XXX	1K $\Omega$ Ni Siemens
QAE2021.XXX	1K $\Omega$ Ni JCI
.XXX	U (Insertion Length in Inches [mm])
.005	2.5 (63.5)
.010	4 (101.6)
.015	6 (152.4)

### Required Tools

- Power screwdriver with 1/4-inch (6 mm) hex extension or medium flat-blade screwdriver
- 1-1/4 inch (32 mm) open-end wrench or equivalent adjustable wrench
- Medium crescent wrench
- Pipe sealant
- Wire stripper

### Expected Installation Time

3 hours

### Prerequisites

- The appropriate field wiring within the maximum wiring run length for the individual field panel or equipment controller must be in place.
- All wiring must comply with National Electric Code (NEC) and local regulations.
- A 1/2-inch (13 mm) NPT mounting coupling must be installed in the piping system at the sensor location. Figures 1 and 2 show two types of installation in a pipe joint.

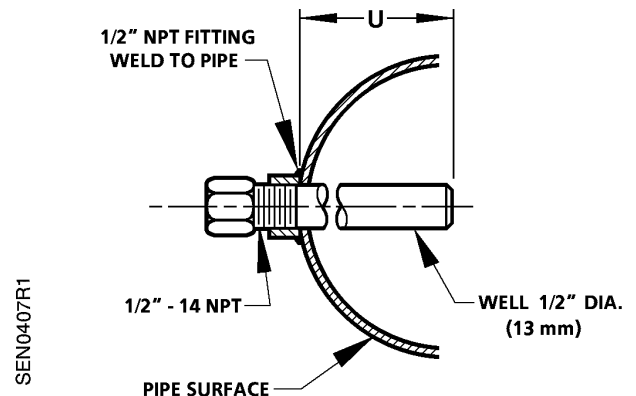

Figure 1. Pipe Surface Installation.

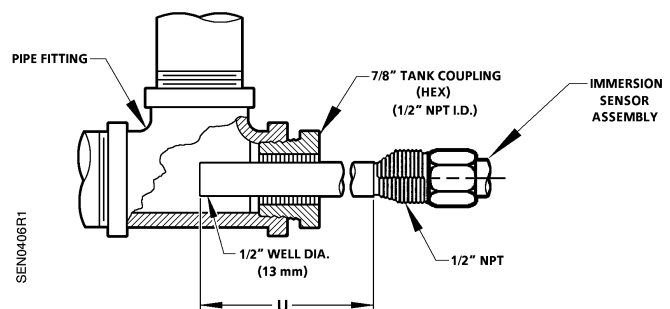

Figure 2. Pipe Joint Installation.

## Installation

**NOTE:** It is not recommended or necessary to separate the well and the pulling elbow to install the sensor assembly. The pulling elbow should only be removed to replace a damaged or defective sensing element.

1. Clean any dust away from the coupling for the well.
2. Apply pipe sealant to the threads of the well and insert the entire sensor assembly into the coupling.
3. Hand-tighten the sensor assembly. Finish tightening the assembly by using a 1-1/4 inch (32 mm) open-end wrench. Tighten the assembly until the outlet of the pulling elbow is aligned with the controller.
4. Pull the field wiring to the pulling elbow and connect the field wiring to the Thermistor. See Figure 3.

**NOTE:** In applications where condensate may accumulate (chillers, low temperature sensing, etc.) seal all wire connections with RTV adhesive (ordered separately, P/N 535-495).

5. Connect the field wiring at the controller as shown in Figure 4.

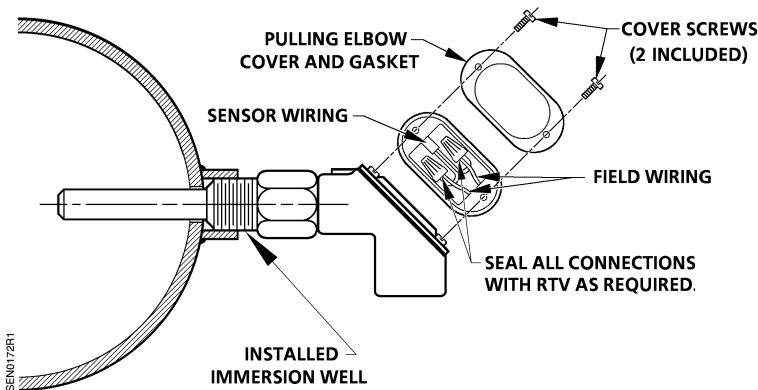

**Figure 3. Immersion Sensor Installation.**

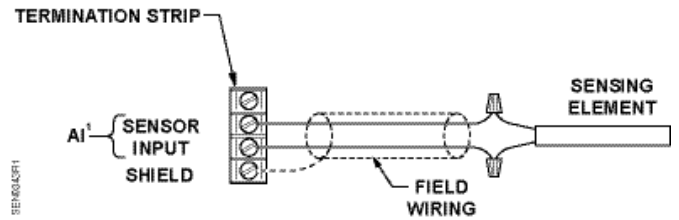

1. Configure the analog input (AI) point for sensor input.

**Figure 4. Wiring to a Controller.**

**NOTE:** 1. Some Controllers may require a shield termination.  
 2. For individual panel wiring details, see the appropriate hardware manual.

The installation is now complete.