

Duct Averaging Sensors, Short Rigid Probe, RTD

Product Description

The 1000 Ω RTD Rigid Probe Duct Averaging Temperature Sensor assemblies sense the average temperature in ductwork where mixing baffles are not provided or where stratification occurs. Each sensor assembly mounts on sheet metal ducts.

Contents

- Short, rigid platinum RTD averaging element
- Two wire nuts
- Electrical box for wiring connections

Product Numbers

Product Number	Sensing Element	Range
544-343-XX	1000 Ω Pt (375 α)	20°F to 120°F (-7°C to 49°C)
XX	Probe Length in Inches (cm)	
18	18 (46)	
24	24 (61)	
36	36 (91)	
48	48 (122)	

Caution Notation

CAUTION		Equipment damage or loss of data may occur if you do not follow a procedure as specified.
----------------	---	---

Required Tools

- Wire cutters
- Small, 1/8-inch, flat-blade screwdriver
- Medium, flat-blade screwdriver
- Four No. 10 \times one-inch sheet metal screws
- Electric drill and 3/8-inch drill bit
- No. 27 drill bit for screw holes

Expected Installation Time

544-343-18 and 544-343-24	1.5 hours
544-343-36 and 544-343-48	2.0 hours

Prerequisites

Field wiring must be pulled to installation site.

Installation

1. Mark the location of four holes on the duct at the place where the unit is to be mounted (see Figure 3). Mark the location in the center of the four mounting holes for a one-inch clearance hole.
2. Drill the one-inch clearance hole. Switch to the No. 27 drill bit and drill the four sheet metal mounting screw holes in the duct or use a conduit knockout punch.
3. Remove the 2-inch \times 4-inch electrical box cover.
4. Pierce the rubber gasket for all four mounting screw locations with the small screwdriver. Push the mounting screws through the holes in the gasket from the inside of the 2-inch \times 4-inch electrical box.
5. Place the unit on the duct into position and fasten it in place with the four mounting screws.



CAUTION:

The 36 and 48-inch probes must be supported within six inches of the tip of the probe.

6. Connect the conduit to the utility box.
7. Pull field wiring to utility box.
8. Connect the sensor leads and field wiring. See Figure 1 for the proper wiring connections.
9. Replace the 2-inch \times 4-inch electrical box cover on the transmitter assembly box.

The installation is now complete.

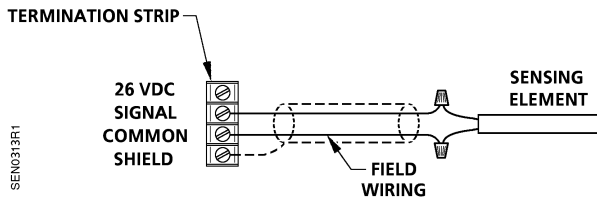

Figure 1. Typical Wiring Connection.

- NOTE:**
1. Some Siemens Industry controllers may require a shield termination.
 2. For individual panel wiring details, refer to the appropriate hardware manual.

Hanger Straps

One possible method of supporting probe 544-343-36 or 544-343-48 is to use 3/4-inch x 20 gauge perforated steel hanger straps, which have 1/4-inch holes centered every 1/2-inch along the strip. This strap can be easily aligned so that a hole is present in the correct position to support the probe. Use No. 10 x one-inch sheet metal screws to secure the strap to the ductwork.

With internal access to the duct, only two holes must be drilled in the duct. Without internal access to the duct, two holes and two one-inch slits must be cut in the duct as shown in Figure 2. Before cutting holes for the screws (and slits, if necessary), string the hanger strap through the duct and place the probe tip in a strap hole.

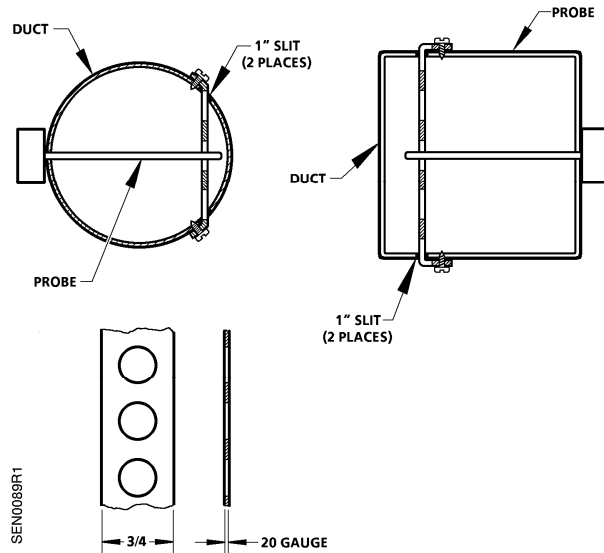

Figure 2. Steel Hanger Used to Support Sensor Probe Tip.

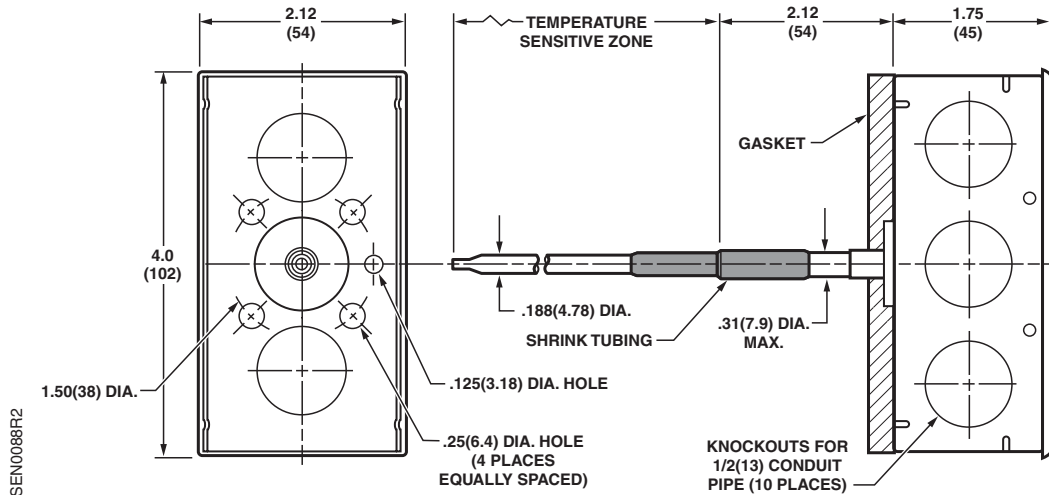

Figure 3 Rigid Duct Averaging Temperature Sensor Mounting Hole Locations.

Information in this publication is based on current specifications. The company reserves the right to make changes in specifications and models as design improvements are introduced. Products or company names mentioned herein may be the trademarks of their respective owners. © 2010 Siemens Industry, Inc.