

Immersion Temperature Sensors with 4 to 20 mA Transmitter

Product Description

The transmitter-equipped Immersion Temperature Sensor provides a 4 to 20 mA input to a controller. It threads into a coupling on a piping system. The sensor assembly includes an immersion well, 100 ohm platinum RTD sensing element, and a transmitter located in the LB wiring housing. See Figure 1.

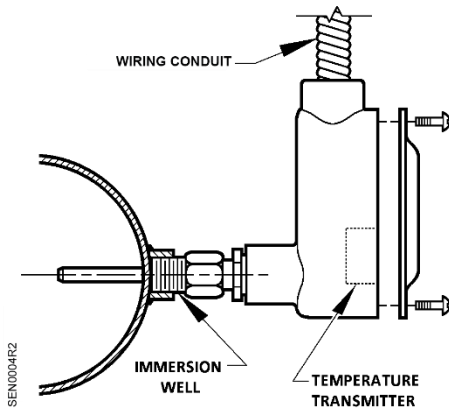

Figure 1. Immersion Sensor.

NOTE: Acceptable wiring conduits are:

- Flexible conduit with liquid-tight conduit adapter
- EMT with liquid-tight conduit adapter
- Rigid NPT with thread sealant
- Rigid NPSM

Product Numbers

Product Number	Sensing Element
536-767-XX	4 to 20 mA, 30°F to 250°F (-1°C to 121°C)
536-774-XX	4 to 20 mA, 20°F to 70°F (-7°C to 21°C)
544-562-XX	4 to 20 mA, 32°F to 212°F (0°C to 100°C)
XX	Insertion Length in Inches (mm)
25	2.5 (63.5)
40	4 (101.6)
60	6 (152.4)

Required Tools

- Power screwdriver with 1/4-inch hex extension or medium flat-blade screwdriver
- 1-1/4 inch open end wrench or equivalent adjustable wrench
- Medium crescent wrench
- Pipe sealant
- Wire stripper

Expected Installation Time

3 hours

Prerequisites

- The appropriate field wiring within the maximum wiring run length for the individual field panel or equipment controller must be in place.

NOTE: All wiring must comply with National Electric Code (NEC) and local regulations.

- A 1/2-inch NPT mounting coupling must be installed in the piping system at the sensor location. Figures 2 and 3 show two types of installation: pipe surface and pipe joint.
- Be sure you have the correct temperature range sensor for the point location.

Instructions

NOTE: It is not recommended or necessary to separate the well and the wiring housing to install the sensor assembly. The LB wiring housing should only be removed to replace a damaged or defective sensing element.

1. Clean any dust away from the coupling for the well.
2. Apply pipe sealant to the threads of the well and insert the entire sensor assembly into the coupling.

- Hand-tighten the sensor assembly. Finish tightening the assembly by using a 1-1/4 inch open-end wrench. Tighten the assembly until the outlet of the LB wiring housing is aligned with the field utility box, controller, and so on.
- Pull the field wiring to the LB wiring housing mounted on the sensor.
- Connect the field wiring to the transmitter with the positive (+) 26V supply lead to the PWR wire and negative signal lead to the SIG wire. See Figure 4 and Table 1.

For 544-562-XX variants, connect the field wiring to the transmitter with the positive (+) 26V supply lead to terminal No. 1 and the negative signal lead to terminal No. 2.

NOTE: In applications where condensate may accumulate (chillers, low temperature sensing, and so on) seal all wire connections with RTV sealant.

- Connect the field wiring at the controller. The installation is now complete.

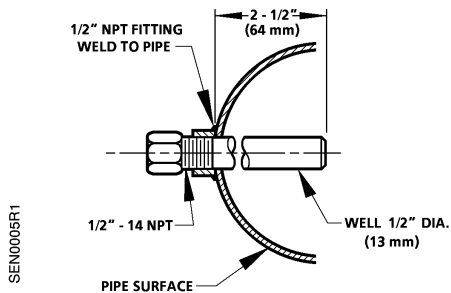

Figure 2. Pipe Surface Installation.

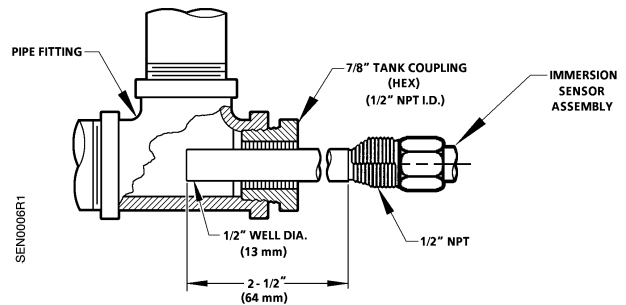

Figure 3. Pipe Joint Installation.

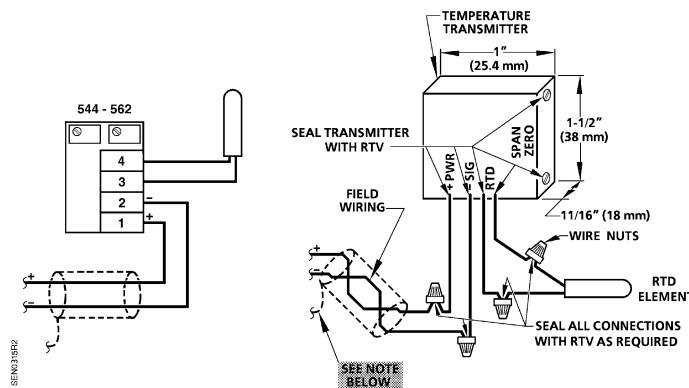

Figure 4. Wiring Connections for 4 to 20 mA Sensors.

NOTE: For individual panel wiring details, see the appropriate hardware manual.

Table 1. Transmitter Lead Wire Color Codes.

Terminal	PWR	SIG	RTD	
Option 1	Red	Brown	Black	Orange
Option 2	Red	Black	White	White

NOTE: Wire colors vary by transmitter supplier.