

OpenAir™ Electronic Damper Actuator GDE Series, Non-spring Return Rotary Post Header AMP

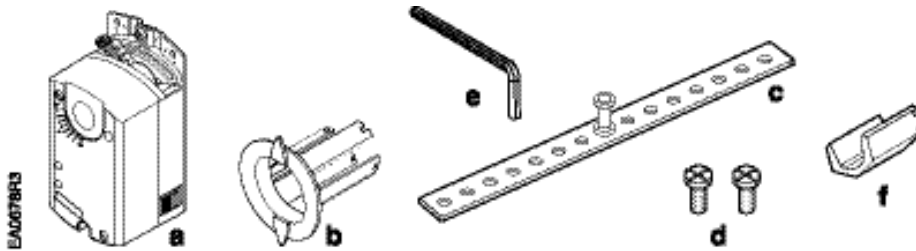

- a. Actuator
- b. Position indicator
- c. Mounting bracket
- d. Mounting screws
- e. 4 mm hex key
- f. Shaft insert for use with 3/8-inch (8 to 10 mm) shafts

Figure 1. Parts of the OpenAir GDE Post Header AMP.

Product Description

Steps for direct-coupled mounting of the OpenAir electronic damper actuators GDE Series, non-spring return, rotary, Post Header AMP model.

Product Numbers

GDE131.1N
GDE131.1N/B (24 pk)
GDE161.1N
GDE161.1N/B (24 pk)

Required Tools

- 4 mm hex wrench
- 4 mm (5/32-inch) drill bit and drill
- Small flat-blade screwdriver
- Marker or pencil

Also Required:

Select the Appropriate Input Cable and

Daisy Chain Cable:

Input Signal Cabling

- 985-131: 3 ft, floating cable, 12 pk
- 985-133: 3 ft, 0 Vdc to 10 Vdc cable, 12 pk
- 985-132: 3 ft, floating cable for use only with the Siemens Building Technologies, Inc. Terminal Equipment Controller (TEC), 12 pk

Daisy chain connecting cable:

- 985-134: 12 ft cable, 12 pk; or
- 985-135: 25 ft cable, 12 pk

Estimated Installation Time

30 minutes per actuator

Warning/Caution Notations

WARNING:		Personal injury/loss of life may occur if you do not follow a procedure as specified.
CAUTION:		Equipment damage or loss of data may occur if you do not follow a procedure as

	specified.
--	------------

Instructions



WARNING:

Do not open the actuator.

NOTE: Place the actuator on the damper shaft with the front of the actuator accessible. The label is on the front side.

1. Determine whether the damper blades will rotate clockwise or counterclockwise to open. See Figure 3.
2. If the blades will rotate counterclockwise, slide the manual override switch to manual, and move the adjustment lever to the right. Return the switch to automatic. See Figure 10.

GDE161.1N

To mount a (modulating) GDE161.1N, set the dual In-line package (DIP) switch to the required positions.

1. To access the DIP switch, raise the tab on the lower left side of the actuator. See Figure 3.
2. The factory setting is clockwise (middle switch). See Figure 2.
3. Close the tab over the DIP switch.

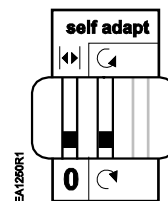

Figure 2.

Instructions, continued

GDE161.1N

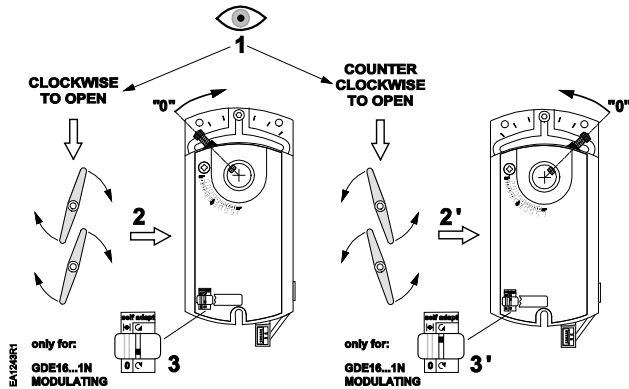

Figure 3. Setting GDE161.1N Direction of Rotation.

NOTE:

For GDE161.1N DIP switch setting options, see the *Technical Instructions EA GDE/GLB-1* (155-187P25).

GDE131.1N

To mount a (floating) GDE131.1N for counter-clockwise rotation, follow the *Direction of Damper Rotation* instructions located in the *Wiring Diagrams* section when wiring the actuator to the controller.

Mounting and Installation

NOTE: The GDE actuator comes with a factory installed 1/2-inch shaft guide. If shaft size is 1/2-inch, proceed with Figure 7.

When using a 3/8-inch shaft:

1. Remove factory installed 1/2-inch guide. See Figure 4.

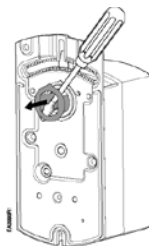

Figure 4. Removing 1/2-inch Ø Shaft Guide for 3/8-in or 5/8-in Shaft.

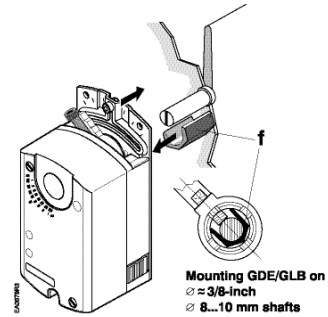

Figure 5. 3/8-inch Ø Shaft, see Figure 1.

2. A 3/8-inch shaft adapter is provided in actuator package.
3. Hold the shaft insert so that the raised tabs are inserted last when placing the insert into the back of the actuator.
4. Proceed to Figure 8.

When using a 5/8-inch shaft:

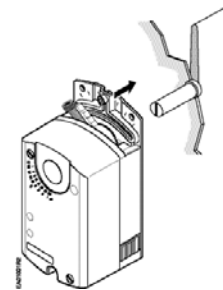

Figure 6. 5/8-inch Ø Shaft.

1. Remove factory installed 1/2-inch guide. See Figure 4.
2. Mount actuator to shaft See Figure 7.

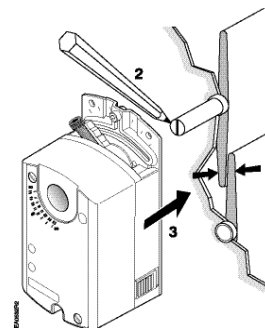

Figure 7. Mounting Actuator to Damper Shaft.

Mounting and Installation, Continued

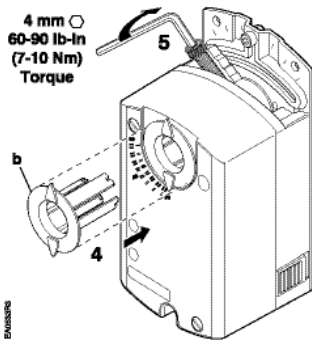

Figure 8. Installing the Position Indicator (b).

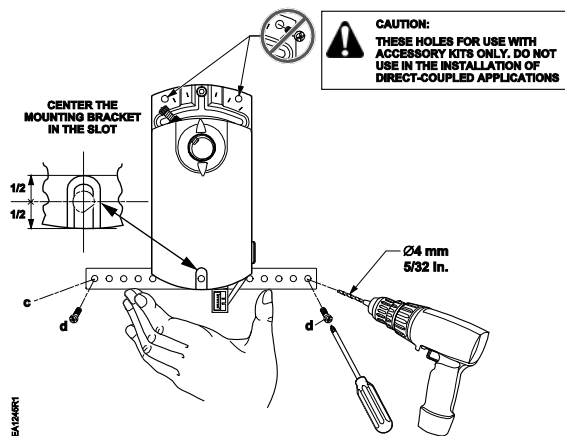

Figure 9. Attaching the Mounting Bracket.

Manual Override

To move the damper blades and lock the position with no power present, do the following:

1. Slide the red manual override knob toward the back of the actuator.
2. Make adjustments to the damper position.
3. Slide the red manual override knob toward the front of the actuator.

Once power is restored, the actuator returns to automated control.

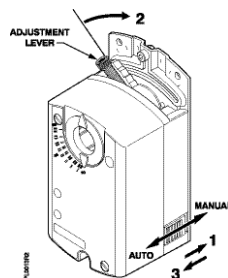

Figure 10. Manual Override.

Mechanical Range Adjustment

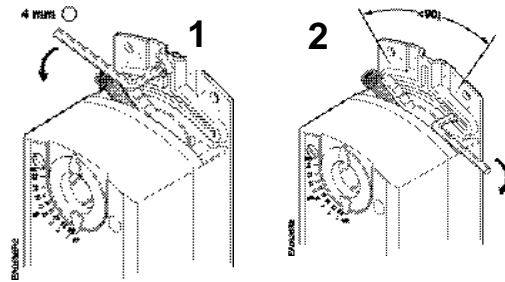

Figure 11. Moving the Mechanical Range Stop.

1. Loosen the stop set screw.
2. Move it along the track to the desired position, and fasten it in place.

Mechanical range limitation and self-adapt feature

1. To use the entire 0V to 10V input signal to control the adjusted range, raise the tab located on the lower left-hand side of the actuator and locate the DIP switches. See Figure 3.
2. Set the self-adapt DIP switch to (ON).
3. Close the tab over the DIP switches.

For example, if you set the locking screw at 70° and turn the self-adapt switch ON, a 5V input signal will drive the damper to 35° (50% of its adjusted range).

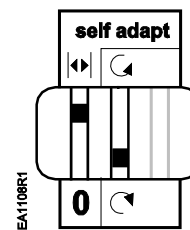

Figure 12.
 Self-adapt Switch in the On Position.
 Factory setting 0 (OFF)



CAUTION:

When turning the self-adaptive feature on, or after software reset with the feature on, the actuator will enter a five-minute calibration cycle as the actuator adjusts to the rotation limits of the system. The software reset happens after power on, or may be caused by electrostatic discharge (ESD) at levels of 2 kV and above.

Wiring

The Post Header AMP has two sets of identical contacts as shown in Figure 14 and Figure 16.

All wiring must conform to NEC and local codes and regulations.

Use earth ground isolating step-down Class 2 transformers. Do not use autotransformers.

Determine the supply transformer rating by summing the total VA of all actuators used. It is recommended that one transformer power no more than 12 actuators.

Table 1.

Floating Input Cables	
985-131	3 ft 12 pk
985-132	3 ft Siemens TEC 12 pk



WARNING:

Installations requiring **CE** Conformance

- All wiring for CE rated actuators must only be separated extra low voltage (SELV) or protective extra low voltage (PELV) per HD384-4-41.
- Use safety-isolating transformers (Class III transformer) per EN 61558. They must be rated for 100% duty cycle.
- Over current protection for supply lines is maximum 10A.



CAUTION:

It is necessary that the output current properly sustain and operate all actuators in a daisy chain configuration.

Wiring Diagrams



CAUTIONS:

Insert the plug into the Post Header AMP from the left to prevent damage to the cable wires. (See Figure 13).

The open bracket to the right of the actuator Post Header AMP is used for strain relief of the customer purchased cables (See *Required Tools*).

Secure the cabling to the actuator bracket with a cable tie as shown in Figure 13.

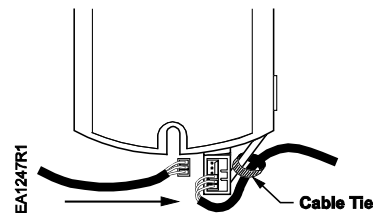

Figure 13. Insert the Plug from the Left.

GDE161.1N

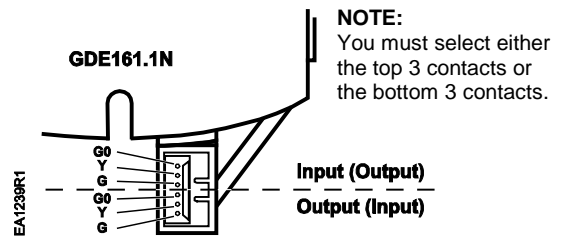

Figure 14. GDE161.1N Post Header AMP.

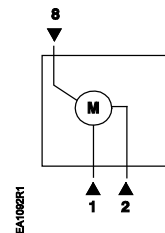

Figure 15. GDE161.1N 0 to 10 Vdc Modulating Control Wiring Diagram.

GDE131.1N

Direction of Damper Rotation

To change the direction of rotation of GDE131.1N actuator, you must switch the Y1 and Y2 wires at the controller.

NOTE: This rotation will affect all actuators in the daisy chain configuration.

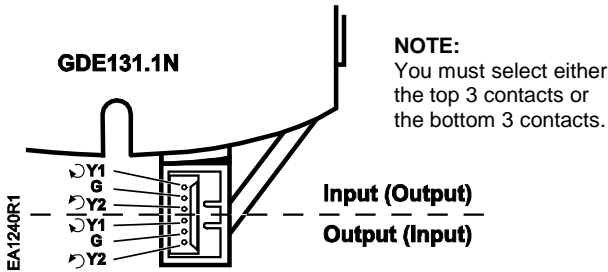

Figure 16. GDE131.1N Post Header AMP.

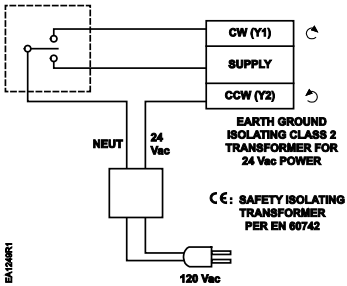

Figure 17. GDE131.1N Floating Control Wiring Diagram.

Daisy Chain

The input cable (purchased separately) brings power and a control signal to the first actuator in a daisy chain configuration.

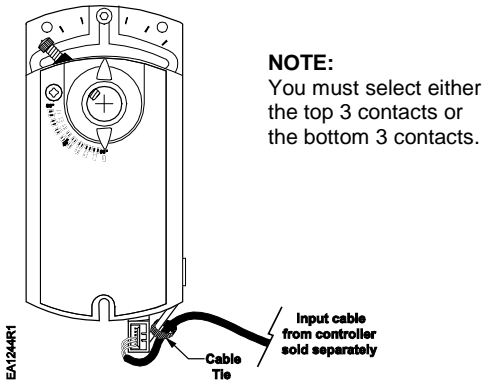

Figure 18. Input Cable Installed in Bottom Three Contacts.

NOTE: You must select either the top 3 contacts or the bottom 3 contacts.

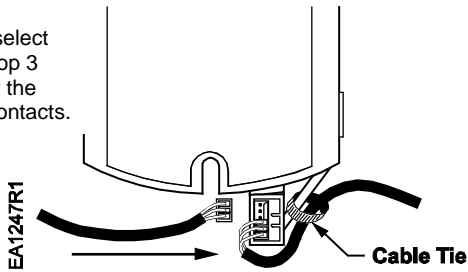

Figure 19. Always Insert Cable From the Left.

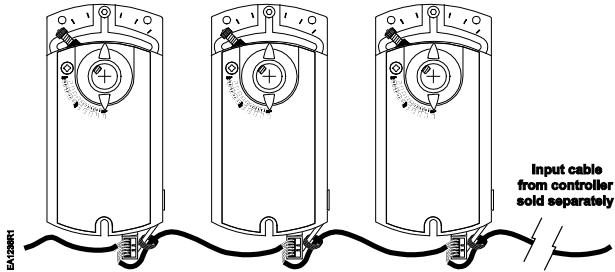

Figure 20. Actuators in Daisy Chain.



WARNING: No more than 12 actuators should be daisy chained together at any time.

Table 2.

Daisy Chain Cables	
985-134	12 ft
	12 pk
985-135	25 ft
	12 pk

Dimensions

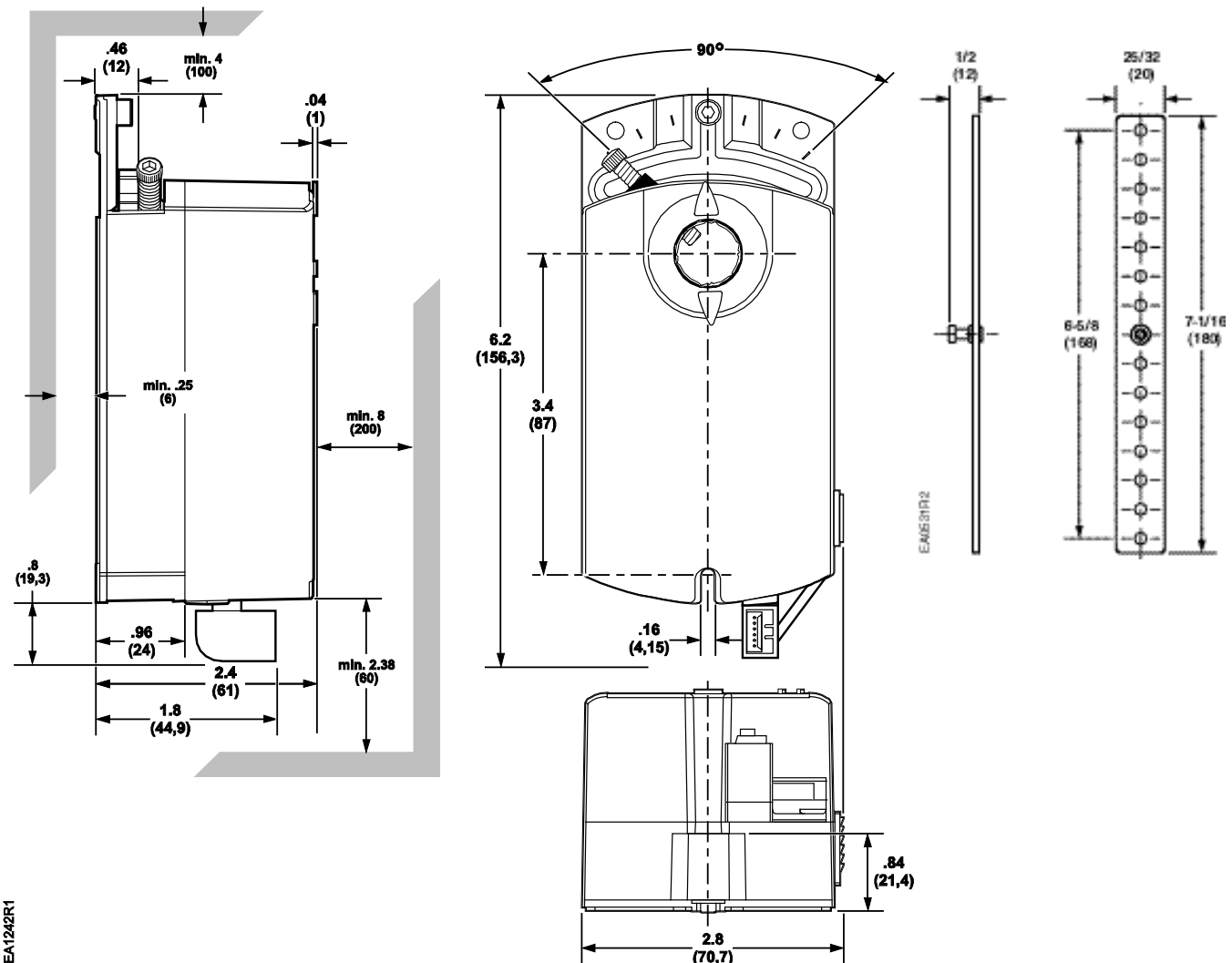

Figure 21. Dimensions of the OpenAir GDE Post Header AMP Actuator and Mounting Bracket in Inches (mm).

References

- EA GDE/GLB-1 155-187P25
 OpenAir™ Electronic Damper Actuators
 GDE/GLB Series Non-spring Return Rotary
 24 Vac Modulating Control
- EA GDE/GLB-2 155-188P25
 OpenAir™ Electronic Damper Actuators
 GDE/GLB Series Non-spring Return Rotary
 24 Vac Three-Position Control

Information in this publication is based on current specifications. The company reserves the right to make changes in specifications and models as design improvements are introduced. OpenAir is a registered trademark of Siemens Industry, Inc. Product or company names mentioned herein may be the trademarks of their respective owners. © 2008 Siemens Industry, Inc.