

POWERS™ CONTROLS No. 4 Pneumatic Damper Actuator

Product Description

The No. 4 Pneumatic Damper Actuator is a totally enclosed pneumatic piston type actuator designed to actuate dampers for ventilating systems, mixing box control, and other applications requiring a large, effective diaphragm area and long stroke. The No. 4 Hesitation Actuator is frequently used to operate the outdoor air damper on unit ventilators.

Product Numbers

See Table 1.

Prerequisites

- Ensure all kits are ordered and available for installation. Kits are listed with each mounting application.
- Have the damper manufacturer drill the mounting holes.
- Have the damper manufacturer weld the mounting lug to the damper frame in frame mounting installations.



WARNING:

Do not remove the jam nut (Figure 1). Spring is under heavy load. Repair by trained personnel only.

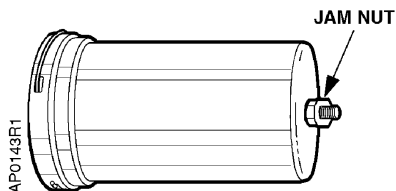

Figure 1. Actuator Jam Nut Location.

Required Tools

- Flat-blade screwdriver
- Adjustable crescent wrench
- Pliers

Warning/Caution Notations

WARNING		Personal injury or loss of life may occur if you do not follow a procedure as specified.
CAUTION		Equipment damage or loss of data may occur if you do not follow a procedure as specified.

Installation

Extended Shaft Mounting-Pivot Actuator

Expected Installation Time: 28 minutes

Actuators: 331-3000, 331-3001, 331-3002, or 331-2973.

These assemblies are designed for 90° damper rotation.

NOTE: Clevis mounts in Crank Radius Hole No. 1 for 90° damper rotation.

1. Slip 3/4-inch (19 mm) diameter hole in the mounting plate over the damper shaft (Figure 2).

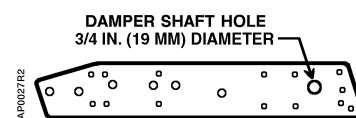

Figure 2. Actuator Mounting Plate.

2. Slip the crank over the 3/8 through 1/2-inch (10 through 13-mm) diameter damper shaft (Figure 3).

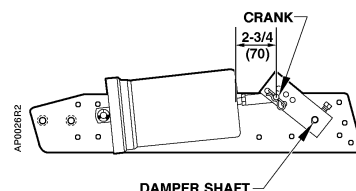

Figure 3. Extended Shaft Mounting.

3. Position the mounting plate and attach it to the duct with four screws.

Table 1. No. 4 Damper Actuator Product Numbers.

Description	Mounting Style	Product Numbers				
		Nominal Spring Range				
		3-7 psi (21-48 kPa)	3-13 psi (21-90 kPa)	5-10 psi (35-69 kPa)	8-13 psi (55-90 kPa)	2-3, 8-13 psi (14-21, 55-90 kPa) Hesitation Model
Actuator, mounting screws (non-pivot)	Front	—	—	—	331-2963	—
Actuator, bracket (non-pivot) 2-3/8 inch stroke for unit ventilator	Fixed	—	—	—	—	331-2974
Actuator, mounting plate, ball joint connector	Fixed	—	331-3018	—	331-3017	—
Actuator, mounting plate, ball joint connector with positioning relay	Fixed	—	—	—	—	—
Actuator, integral pivot	Pivot	331-2904 ¹	331-2905 ¹	331-2906 ¹	331-2961 ¹	—
Actuator, integral pivot, clevis and clevis pin for use with frame mounting accessory	Pivot	331-2929	331-2930	—	331-2968	—
Actuator, integral pivot with pivot post ²	Universal kit	331-3000	331-3001	331-3002	331-2973 ¹	—
Actuator, integral pivot with pivot post, and positioning relay ²	Universal kit with positioning relay	—	—	—	332-2973	—

¹ UL Recognized Components for Fire/Smoke Applications.

² Mounted on plate for extended shaft with clevis and crank for 3/8-inch (10-mm), 7/16-inch (11-mm), or 1/2-inch (13-mm) diameter shaft. Parts for frame mounting (blade drive) are included with kit.

NOTE: When the actuator is ordered with universal mounting, the mounting plate, pivot post and hardware, clevis, damper crank, rocker arm, and all screws/nuts are included. Order other frame mounting accessories as required if not supplied by damper manufacturer.

Installation, Continued

Extended Shaft Mounting-Fixed Actuator

Expected Installation Time: 28 minutes

Actuator with mounting bracket: 331-2974

Clevis: 331-801

Linkage Kit: 331-958

1. Determine the application from Table 2 and then select appropriate **X** and **Y** dimensions. Select a rigid section of the duct, if possible, and draw these lines on the duct.



CAUTION:

It is important to use the **X** and **Y** dimensions from Table 2 to position the actuator to ensure that the crank is approximately perpendicular to the actuator shaft at half its stroke (see Figure 4). This will prevent the linkage from scissoring or locking up.

Table 2. Fixed Mounted Assembly Dimensions.

Application	Dimensions in Inches (mm)		Crank Radius Hole
	X	Y	
4-inch (102 mm) Stroke – 90° Rotation	8-1/2 (216)	2 (51)	1
4-inch (102 mm) Stroke – 70° Rotation	8-1/2 (216)	3 (76)	2
3-inch (76 mm) Stroke – 90° Rotation	8 (203)	1-1/2 (38)	3
3-inch (76 mm) Stroke – 60° Rotation	8 (203)	2-1/2 (64)	4

NOTE: Crank Radius Holes No. 5 and 6 are used for No. 3 Pneumatic Damper Actuators only.

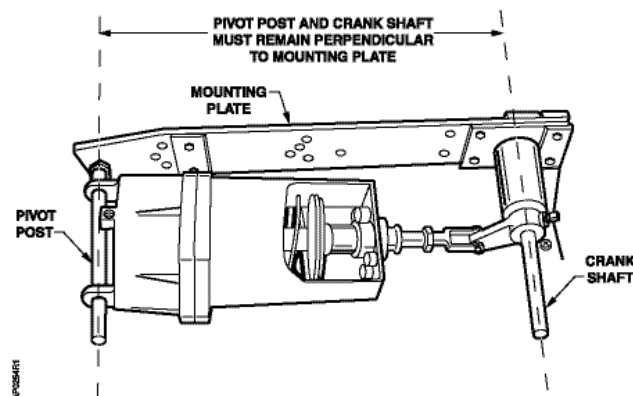

Figure 4. Perpendicular Mounting.

2. Place front of actuator on **X** dimension line so that the actuator shaft faces damper shaft. Place center line of actuator over **Y** dimension line (see Figure 5).
3. Thread Clevis 331-801 on to actuator shaft and tighten against locknut. Assemble Linkage Kit 331-958 to actuator assembly (see Figure 4). The linkage is assembled so that the damper shaft will rotate counterclockwise as actuator pressure increases. This is a typical normally closed damper installation.

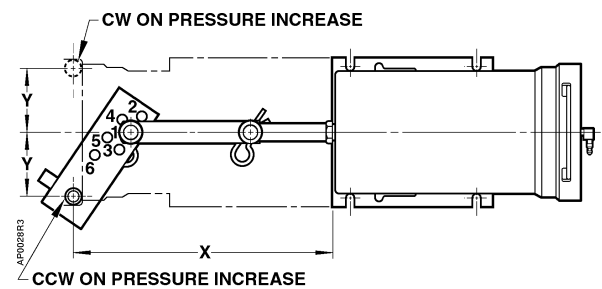

Figure 5. Fixed Mounted Actuator Assembly.

Frame Mounting

Expected Installation Time: 3 hours

Actuator: 331-3000, 331-3001, 331-3002, or 331-2973.

1. If the damper frame is aluminum, light gauge sheet metal, or an unusual shape, bolt a 3/16-inch (5 mm) thick, flat piece of steel to the frame where the mounting lug is to attach. The mounting lug can then be welded to it.
2. Weld the mounting lug parallel and 5/16-inch (8 mm) from the inside edge of the damper frame and perpendicular to it (Figure 6). Weld the lug along both sides. The lug should be as close as possible to the corner of the damper frame to minimize deflection. The damper manufacturer should weld the lug.
3. If the damper frame is aluminum, light gauge sheet metal, or an unusual shape, bolt a 3/16-inch (5-mm) thick, flat piece of steel to the frame. Then, weld the mounting lug to the piece of steel.

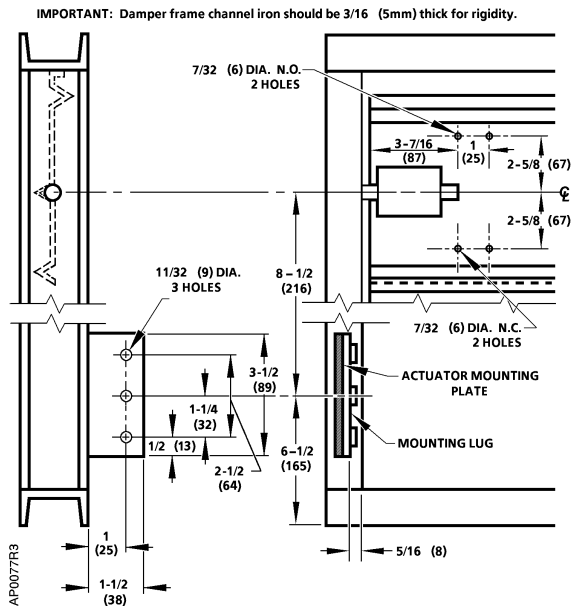

Figure 6. Frame Mounting Dimensions. Dimensions in Inches (Millimeters).

4. Attach rocker to blade in proper position for normally open or normally closed damper (Figure 6).
5. Attach mounting plate to mounting lug.
 - a. Normally closed damper: attach plate to lug (Figure 7). Place pivot post in Hole 5.

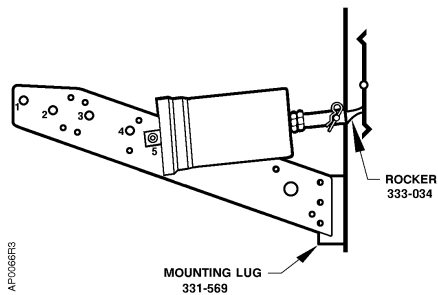

Figure 7. No. 4 Actuator Frame Mounting, Normally Closed Damper.

- b. Normally open damper: attach plate to lug (Figure 8). Place pivot post in Hole 6.

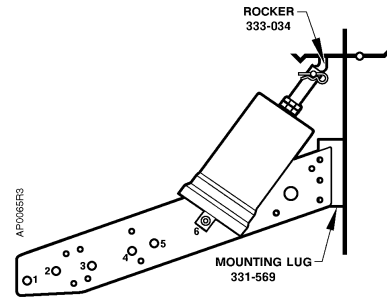

Figure 8. No. 4 Actuator Frame Mounting, Normally Open Damper.

6. Fasten clevis to rocker. Discard crank and other parts not used.
7. The actuator mounting plate has a tendency to pivot at the point where the lug is welded to the damper frame when the actuator strokes. It is recommended that some means be devised in the field to prevent this from happening. A threaded rod attached to the mounting plate and duct wall will normally work.

Hesitation Actuator Adjustment

Expected Installation Time: 15 minutes

1. To obtain an initial hesitation point, add air pressure to actuator until shaft travels the desired distance.
2. Turn locknuts on cycle adjustment rods until they contact lower housing and then lock together. Tighten cycle adjustment nuts evenly to ensure smooth operation.

The installation is now complete.

References

AP 331-2 POWERS™ Controls No. 4 Pneumatic Damper Actuator Technical Instructions, (155-032P25)

TB 181, Maximum Thrust Ratings of Pneumatic Damper Actuators Technical Bulletin, (155-219P25)

Information in this publication is based on current specifications. The company reserves the right to make changes in specifications and models as design improvements are introduced. POWERS is a trademark of Siemens Industry, Inc. Other product or company names mentioned herein may be the trademarks of their respective owners. © 2017-2021 Siemens Industry, Inc.