

## Packing Replacement Kit for Flowrite™ VF 599 Series Valves

### Product Description

This kit contains a packing cartridge assembly and copper gasket to replace either the normal duty or high temperature packing in a Flowrite VP 599 Series Flanged Valve. The kits for 2-1/2 to 6-inch valves also include one 10 mm and one 14 mm stem retainer clip.



### Product Numbers

Valve Size	Normal Duty Packing	High Temperature Packing
1/2 to 2 inch (15 to 50 mm)	599-03390	599-03391
2-1/2 to 6 inch (65 to 150 mm)	599-08020	599-08021

### Required Tools

- 1-1/16 inch open-end wrench for 1/2 to 2-inch (15 to 50 mm) valves or adjustable wrench
- 1-1/2 inch open-end wrench for 2-1/2 to 6-inch (65 to 150 mm) or adjustable wrench
- See the tools list with each actuator

### Warning/Caution Notations

<b>WARNING</b>		Personal injury/loss of life may occur if a procedure is not performed as specified.
<b>CAUTION</b>		Equipment damage, or loss of data may occur if the user does not follow procedure as specified.

### Expected Installation Time

90 minutes to replace the stem packing for an installed in-line valve with an actuator which must be removed and reinstalled.

30 minutes to replace the stem packing at a bench for a non-installed valve without an actuator attached.

### Prerequisites



#### WARNING:

Isolate the valve so that the medium (water steam, etc.) will not leak out of the valve when the valve body is disassembled.



#### WARNING:

Remove and cap the air line or disconnect the power to the actuator before removing the actuator from the valve.

### Installation

Remove the actuator using the instructions from the following pages.

4-inch Pneumatic Actuator	page 2
8-inch Pneumatic Actuator	page 3
12-inch Pneumatic Actuator	page 4
SKB/C Actuators	page 6
SKD Actuators	page 7
SQX Actuators	page 7
Electro-Mechanical Actuator	page 8

### Removing the packing cartridge

1. Using an open-end wrench, remove the packing cartridge assembly.
2. Remove and discard the copper gasket.
3. Examine the stem for nicks and scratches. The plug and stem assembly should be replaced if there is any damage.
4. Clean the bonnet threads and the stem to remove any build-up.

### Installing the packing cartridge

1. Place the new copper gasket on the valve bonnet. See *Figure 1*.

## Installation, Continued

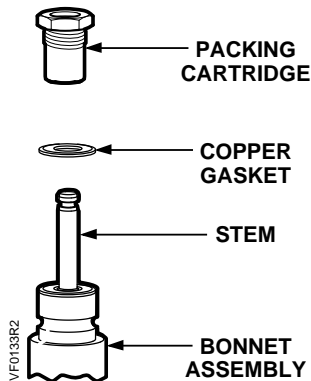

Figure 1. Packing Replacement.

2. Insert the new packing assembly cartridge in the valve bonnet.
3. Tighten with an open-end wrench using 35 to 40 lb-ft (47 to 54 Nm) torque on the 1/2 to 2-inch valves and 110 to 140 lb-ft (150 to 190 Nm) torque on the flanged valves. See Figure 2.

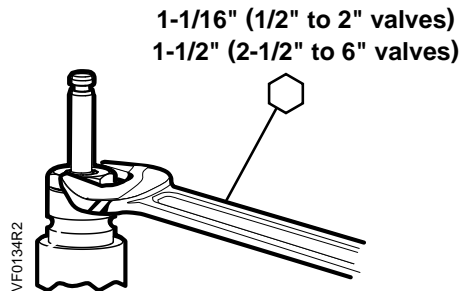

Figure 2. Removing and Replacing the Packing Cartridge.

4. Return to the actuator instructions for assembling the actuator to the valve.

## 4-inch Pneumatic Actuator

### Tools

- 5 mm hex wrench
- 5/16-inch hex wrench
- Air line plug
- Squeeze bulb (baumanometer)
- Pressure gauge and tee
- Tubing



### CAUTION:

Do not damage or scratch the polished surface of the valve stem.

## Removing the actuator

1. Remove and cap the air line to the actuator.
2. Using the squeeze bulb, apply 2 psi of pressure above the start point of the actuator range.
3. Loosen the two stem retainer screws with the 5 mm hex wrench. See Figure 3.

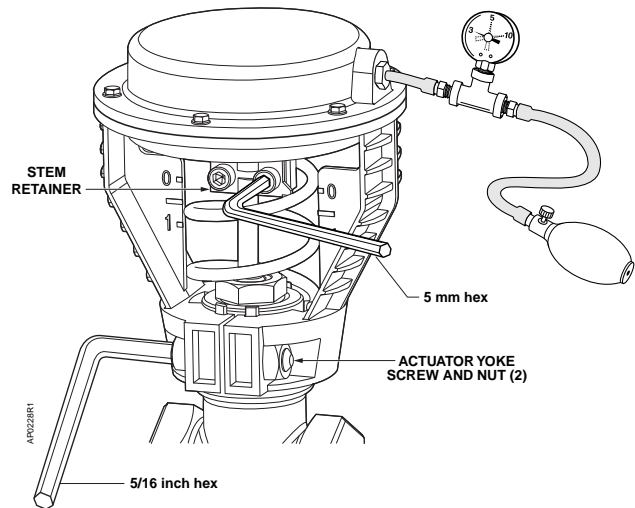

Figure 3. 4-inch Pneumatic Actuator.

4. Lower the valve stem to avoid damaging the valve stem.
5. Use a 5/16-inch hex wrench to loosen the actuator yoke screws.
6. Remove and retain the yoke screws and nuts. See Figure 4.

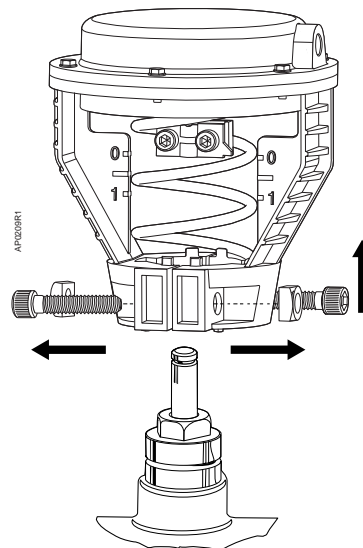

Figure 4. Removing the Actuator.

## Installation, Continued

7. Remove the actuator from the valve bonnet.
8. Return to the instructions for *Removing the packing cartridge*.

### Assembling the actuator to the valve

1. Raise the valve stem.
2. Place the actuator onto the valve bonnet, and using a 5/16-inch hex wrench fasten it with the two yoke screws and nuts. See *Figure 5*.

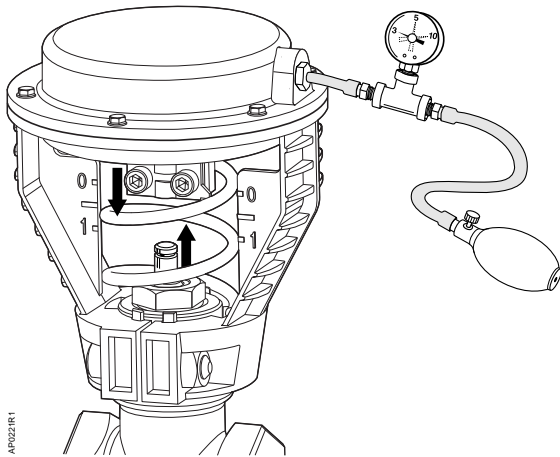

**Figure 5. Lowering the Stem Retainer.**

3. Using a squeeze bulb, apply enough air pressure to lower the stem retainer to meet the valve stem.
4. Use a 5 mm hex wrench to tighten the stem retainer around the valve stem. See *Figure 6*.

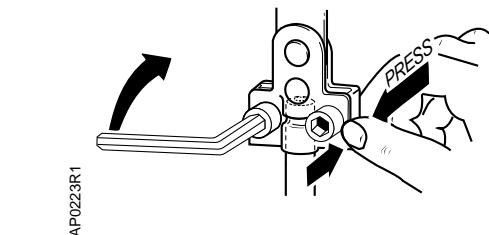
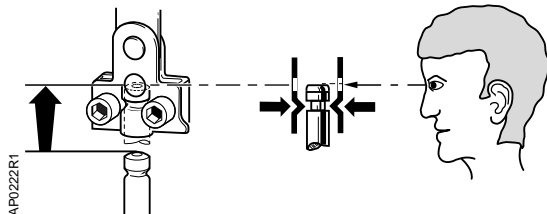

**Figure 6. Fastening the Valve Stem in the Stem Retainer.**

5. Attach the air line.

Siemens Industry, Inc.

## 8-inch Pneumatic Actuator

### Tools

- Air line plug
- 3/4-inch open-end wrench
- 1-inch open-end wrench
- 24 mm open-end wrench
- 3/8-inch open-end wrench



### CAUTION:

Do not damage or scratch the polished surface of the valve stem.

### Removing the actuator

1. Remove and cap the air line to the actuator.
2. Decrease any preload tension on the adjustment screw using 3/4-inch wrench. See *Figure 7*.

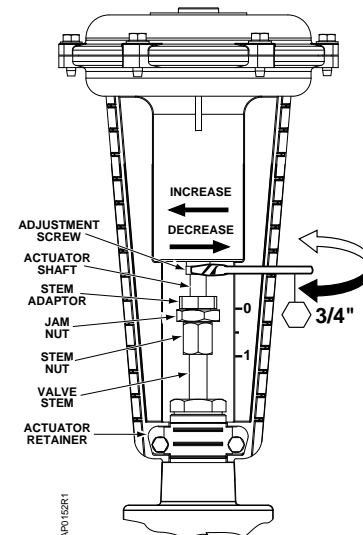

**Figure 7. 8-inch Actuator Spring Adjustment.**

3. Hold the jam nut with a 1-inch wrench and loosen the stem nut with a 24 mm wrench. See *Figure 8*.

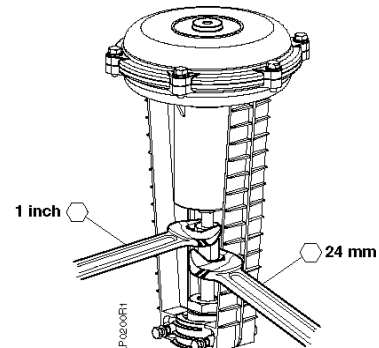

**Figure 8. 8-inch Pneumatic Actuator.**

## Installation, Continued

4. Lower the valve stem to avoid damaging the valve stem.
5. Use a 3/8-inch open-end wrench to loosen the actuator retainer screws and remove the actuator retainer. See *Figure 9*.

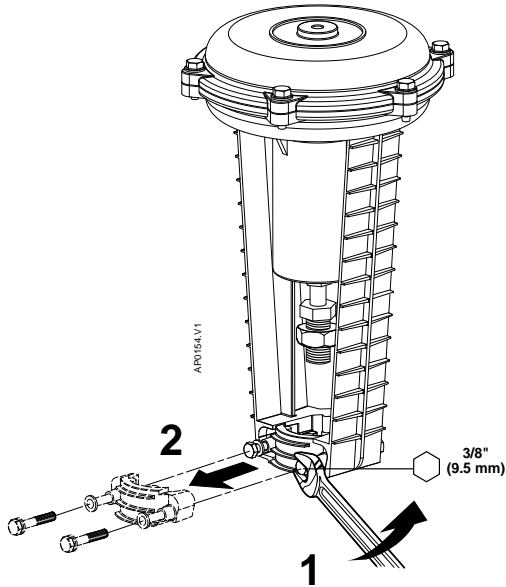

Figure 9. Removing the Actuator Retainer.

6. Remove the actuator from the valve bonnet by pushing the actuator away from the bonnet.
7. Remove and retain the stem retainer clip and stem nut from the valve stem. See *Figure 10*.

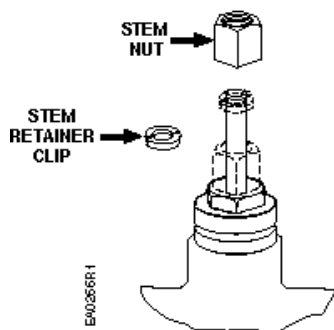

Figure 10. Stem Nut and Stem Retainer Clip.

8. Return to the instructions for *Removing the packing cartridge*.

## Assembling the actuator to the valve

1. Place the stem nut over the valve stem and attach the stem retainer clip.
2. Place the actuator onto the valve bonnet, and fasten it with the actuator retainer.

3. Use a 3/8-inch wrench to tighten the actuator retainer screws.
4. Raise the valve stem so that the stem nut can be fastened to the stem adapter.
5. Hold the jam nut with a 1-inch wrench and tighten the stem nut with a 24 mm wrench.

If necessary, make any spring start point adjustment.

## Spring adjustment

The top edge of the stem nut measures the valve stem position. The “0” marking on the actuator yoke indicates stem up position. The “1” mark indicates stem down position.

With the actuator in an upright position and the stem visible as shown in *Figure 7*, use a 3/4-inch open-end wrench to turn the adjustment screw.

- For Normally Open Valves: To increase the start to close pressure, turn the adjustment screw from right to left. To decrease, turn the adjustment screw from left to right.
- Normally Closed Valves: To increase the start to open pressure, turn the adjustment screw from right to left. To decrease, turn the adjustment screw from left to right.

**NOTE:** As the line pressure differential across the valve increases, the spring span will increase.

## 12-inch Pneumatic Actuator

### Tools

- Air line plug
- 1-1/16 inch open-end wrench
- 24 mm open-end wrench
- 3/8-inch open-end wrench



### CAUTION:

Do not damage or scratch the polished surface of the valve stem.

## Removing the actuator

1. Remove and cap the air line to the actuator.
2. Decrease any preload tension on the adjustment screw using 1-1/16 inch wrench. See *Figure 11*.

## Installation, Continued

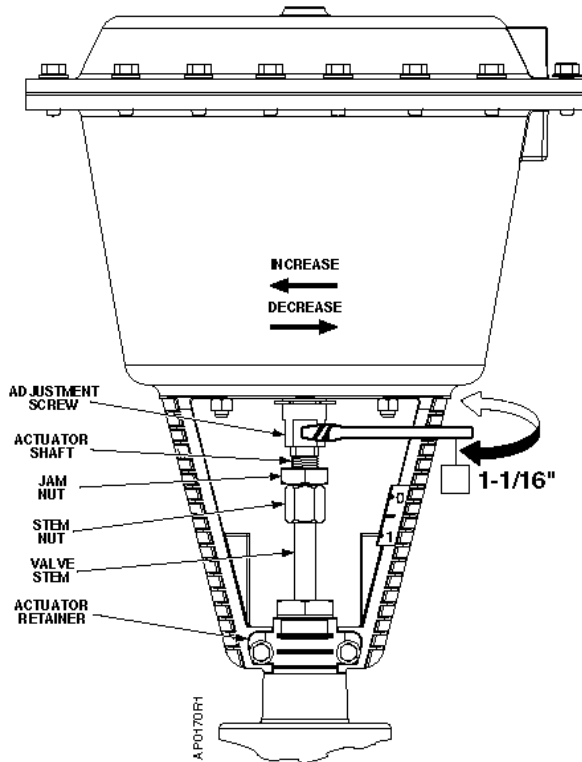

**Figure 11. 12-inch Actuator Spring Adjustment.**

3. Hold the adjustment screw with a 1-1/16 inch wrench and loosen the stem nut with a 24 mm wrench. See *Figure 12*.

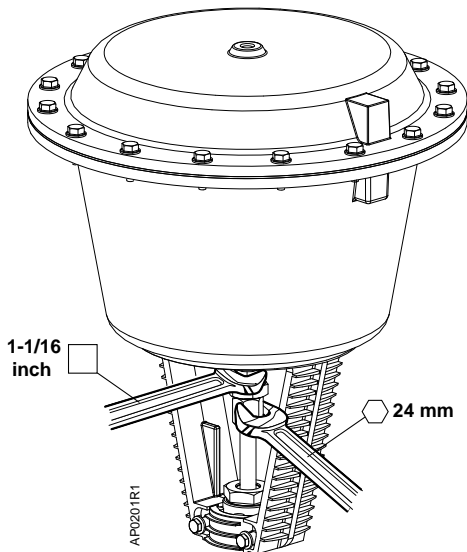

**Figure 12. 12-inch Pneumatic Actuator.**

4. Lower the valve stem to avoid damaging the valve stem.

5. Use a 3/8-inch open-end wrench to loosen the actuator retainer screws and remove the actuator retainer. See *Figure 13*.

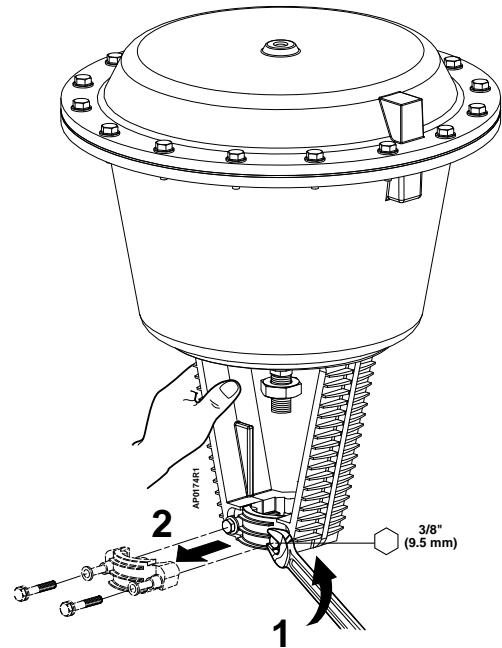

**Figure 13. Removing the Actuator Retainer.**

6. Remove the actuator from the valve bonnet by pushing the actuator away from the valve bonnet.
7. Remove and retain the stem retainer clip and stem nut from the valve stem. See *Figure 10*.
8. Return to the instructions for *Removing the packing cartridge*.

### Assembling the actuator to the valve

1. Place the stem nut over the valve stem and attach the stem retainer clip.
2. Place the actuator onto the valve bonnet, and fasten it with the actuator retainer.
3. Use a 3/8-inch wrench to tighten the actuator retainer screws.
4. Raise the valve stem so that the stem nut can be fastened to the stem adapter.
5. Hold the adjustment screw with a 1-1/16 inch wrench and tighten the stem nut with a 24 mm wrench.
6. If necessary, make any spring start point adjustment.

## Installation, Continued

### Spring adjustment

The top edge of the stem nut measures the valve stem position. The "0" marking on the actuator yoke indicates stem up position. The "1" mark indicates stem down position.

With the actuator in an upright position and the stem visible as shown in *Figure 11*, use a 1-1/16 inch open-end wrench to turn the adjustment screw.

- For Normally Open Valves: To increase the start to close pressure, turn the adjustment screw from right to left. To decrease, turn the adjustment screw from left to right.
- Normally Closed Valves: To increase the start to open pressure, turn the adjustment screw from right to left. To decrease, turn the adjustment screw from left to right.

**NOTE:** As the line pressure differential across the valve increases, the spring span will increase.

### SKB/C Actuators

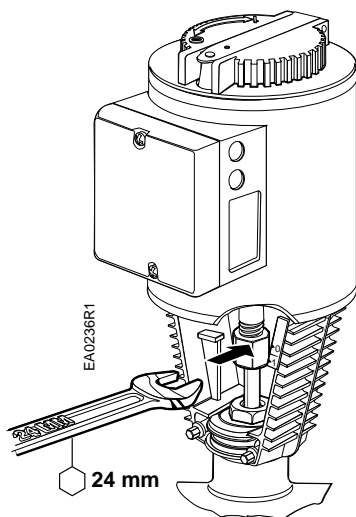

Figure 14. SKB/C Actuators.

#### Tools

- 1-inch open-end wrench
- 24 mm open-end wrench
- 3/8-inch open-end wrench



#### CAUTION:

Do not damage or scratch the polished surface of the valve stem.

### Removing the actuator

1. Turn off the power to the actuator.
2. Use a 24 mm open-end wrench to loosen the stem nut from the actuator shaft.
3. Lower the valve stem to avoid damaging the valve stem.
4. Use a 3/8-inch open-end wrench to loosen the actuator retainer screws and remove the actuator retainer. See *Figure 9*.
5. Remove the actuator from the valve bonnet.
6. Remove and retain the stem retainer clip and stem nut from the valve stem. See *Figure 15*.

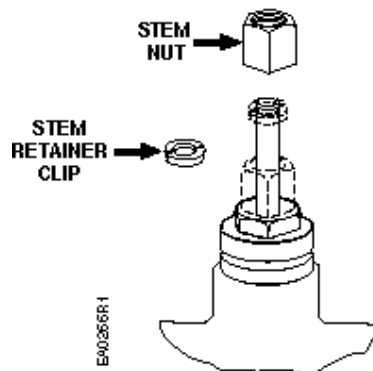

Figure 15. Stem Nut and Stem Retainer Clip.

7. Return to the instructions for *Removing the packing cartridge*.

### Assembling the actuator to the valve

1. Place the stem nut over the valve stem and attach the stem retainer clip. See *Figure 15*.
2. Place the actuator onto the valve bonnet, and fasten it with the actuator retainer.
3. Use a 3/8-inch wrench to tighten the actuator retainer screws.
4. Raise the valve stem so that the stem nut can be fastened to the stem adapter.
5. Tighten the stem nut with a 24 mm wrench.

## Installation, Continued

### SKD Actuators

#### Tools

- 5 mm hex wrench



#### CAUTION:

Do not damage or scratch the polished surface of the valve stem.

### Removing the actuator

1. Turn off the power to the actuator.
2. Rotate the manual override knob three turns. See *Figure 16*.

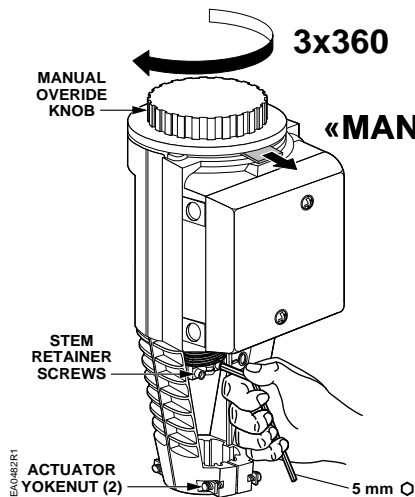
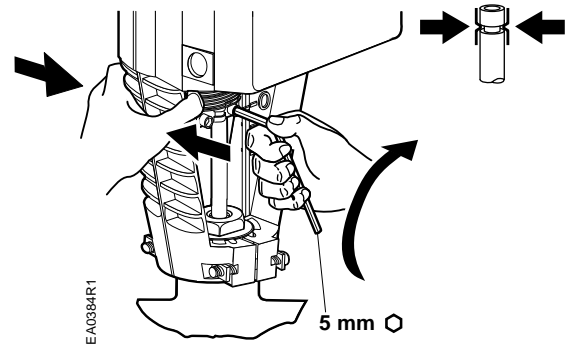

**Figure 16. SKD Actuator.**

3. Use a 5 mm hex wrench to loosen the stem retainer screws.
4. Lower the valve stem.
5. Use a 5 mm hex wrench to loosen the yoke nuts.
6. Remove the actuator from the valve, being careful not to damage the valve stem.
7. Return to the instructions for *Removing the packing cartridge*.

### Assembling the actuator to the valve

1. Place the actuator onto the valve bonnet. Finger tighten the yoke nuts.
2. Raise the valve stem to meet the stem retainer.
3. Hold the stem retainer in place as you tighten it around the valve stem. See *Figure 17*.



**Figure 17. Fastening the Valve Stem in the Stem Retainer.**

4. Hold the actuator in place as you fasten the yoke nuts with a 5 mm hex wrench.
5. Rotate the manual override knob until the red tab indicates Automatic mode.

### SQX Actuators

#### Tools

- 5 mm hex wrench



#### CAUTION:

Do not damage or scratch the polished surface of the valve stem.

### Removing the actuator

1. Turn off the power to the actuator.
2. Rotate the manual override knob one turn.
3. Use a 5 mm hex wrench to loosen the stem retainer screws. See *Figure 18*.

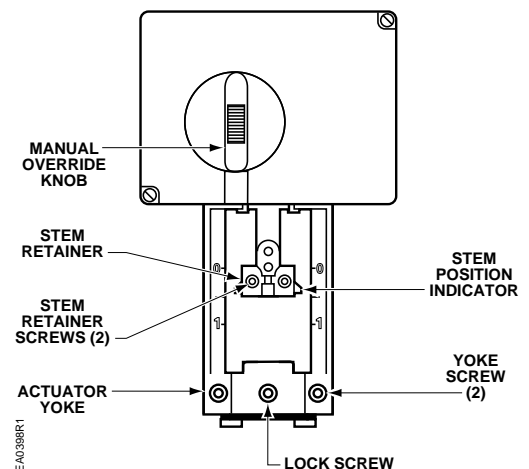

**Figure 18. SQX Actuator.**

## Installation, Continued

4. Lower the valve stem.
5. Use a 5 mm hex wrench to loosen the lock screw and the yoke nuts.
6. Remove the actuator from the valve, being careful not to damage the valve stem.
7. Return to the instructions for *Removing the packing cartridge*.

### Assembling the actuator to the valve

1. Place the actuator onto the valve bonnet.
2. Raise the valve stem to meet the stem retainer.
3. Hold the stem retainer in place as you tighten it around the valve stem. See *Figure 6*.
4. Hold the actuator in place as you fasten the yoke nuts and lock screw with a 5 mm hex wrench.

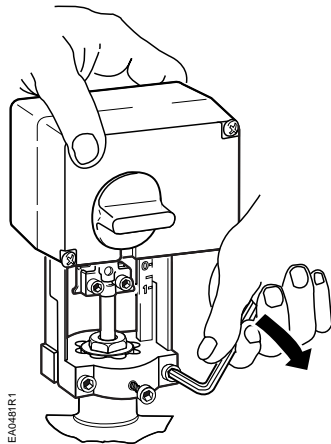

Figure 19. Fastening the SXQ Actuator to the Valve.

### Electro-Mechanical Actuators

#### Tools

- 5/32-inch hex wrench
- Medium flat-blade screwdriver



#### CAUTION:

Do not damage or scratch the polished surface of the valve stem.

### Removing the actuator

1. Turn off the power to the actuator.
2. Use the screwdriver to pry off the linkage cover from the linkage body assembly.

3. Remove the stem clip holding the valve stem. See *Figure 20*.

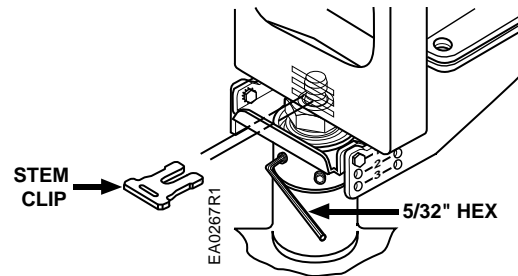

Figure 20. Electro-Mechanical Actuator.

4. Lower the valve stem.
5. Use a 5/32-inch hex wrench to loosen the set screws in the bonnet bracket. See *Figure 20*.
6. Remove the actuator from the valve bonnet being careful not to damage the valve stem.
7. Remove the e-ring from the valve stem.
8. Return to the instructions for *Removing the packing cartridge*.

### Assembling the actuator to the valve

1. Fasten the e-ring to the valve stem.
2. Raise the valve stem to the desired height.
3. Place the actuator over the valve bonnet.
4. Use a 5/32-inch hex wrench to tighten the set screws in the bonnet bracket.
5. Insert the stem clip through the bottom slot in the cage. See *Figure 21*.

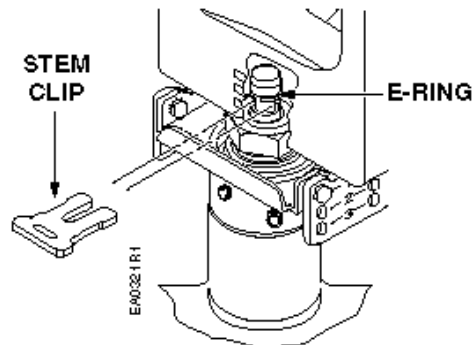

Figure 21. Location of the Stem Clip and E-ring.

6. Fasten the stem clip in the groove of the valve stem beneath the e-ring.
7. Place the linkage cover onto the linkage body assembly.

The installation is now complete.



## References

### Technical Instructions:

4-inch Pneumatic Actuator AP 599-3  
*155-183P25*

8-inch Pneumatic Actuator AP 599-1  
*155-161P25*

12-inch Pneumatic Actuator AP 599-2  
*155-162P25*

SKB/C Modulating Control EA 599-1  
*155-163P25*

SKB/C Floating Control EA 599-2  
*155-171P25*

SKD Modulating Control EA 599-4  
*155-180P25*

SKD Floating Control EA 599-5  
*155-181P25*

SQX Modulating Control EA 599-6  
*155-182P25*

SQX Floating Control EA 599-7  
*155-186P25*

Electro-Mechanical EA 599-3  
*155-172P25*

### Installation Instructions:

4-inch Pneumatic Actuator  
*129-228*

8-inch Pneumatic Actuator  
*129-186*

12-inch Pneumatic Actuator  
*129-184*

SKB/C Modulating Control and Floating Control  
*129-185*

SKD Modulating Control and Floating Control  
*129-217*

SQX Modulating Control and Floating Control  
*129-227*

Electro-Mechanical  
*129-221*

Information in this publication is based on current specifications. The company reserves the right to make changes in specifications and models as design improvements are introduced. Flowrite is a registered trademark of Siemens Industry, Inc. Product or company names mentioned herein may be the trademarks of their respective owners. © 2009 Siemens Industry, Inc.