

SAV Electronic Valve Actuator



Product Description

The SAV Electronic Valve Actuator requires a 24 Vdc or 24 Vac, Class 2, supply signal to control a Siemens flanged, Pressure Independent Control valve with a 1-1/2-inch (40 mm) standard stroke.

Product Number

SAV61.00U Proportional Control Actuator

Warning/Caution Notations

WARNING:		Personal injury or loss of life may occur if you do not follow a procedure as specified.
CAUTION:		Equipment damage or loss of data may occur if you do not follow a procedure as specified.



CAUTION:

SAV Actuators can only be used for hot or chilled water installations.

Required Tools

- 4 mm hex wrench, or 10 mm wrench
- Flat-blade screwdriver or Phillips screwdriver to remove wiring compartment cover

Expected Installation Time

30 minutes Wiring a factory-installed actuator

45 minutes Field replacement of actuator

Prerequisites



WARNING:

If mounting the actuator to a valve already in line, either close the shut-off valves in the piping (upstream first, then downstream) or switch off the pump to allow the differential pressure in the valve to drop.

Mounting Positions

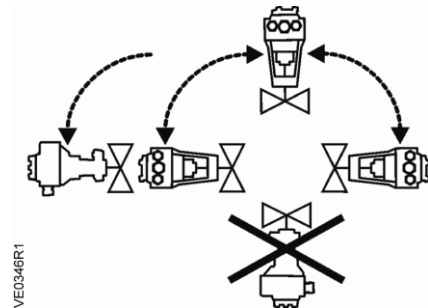

Figure 1. Acceptable Indoor Mounting Positions.

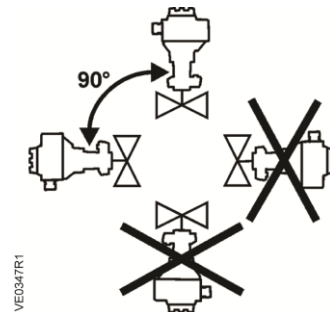
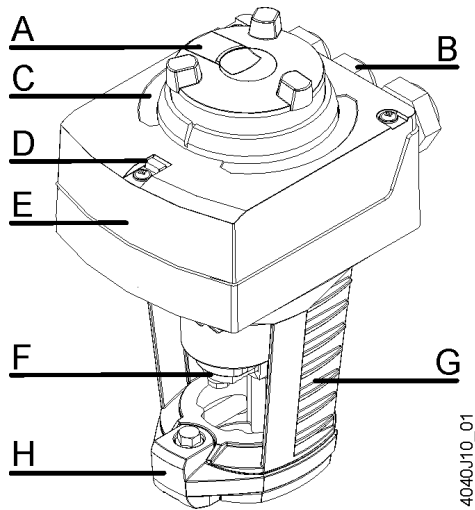

Figure 2. Acceptable Outdoor Mounting Positions with Weather Shield for NEMA 3R Protection.



A	Manual adjuster (with slide switch)
B	Wiring knockouts
C	Position indication
D	Status indication
E	Housing cover
F	Valve stem coupling
G	Yoke
H	Bonnet connection U-bracket

Installation



CAUTION:
 Do not damage or scratch the polished surface of the valve stem.

Mounting an Actuator to a Valve

1. Ensure stem connection plate in the Valve Stem Coupling is in the OPEN position. See Figure 3.

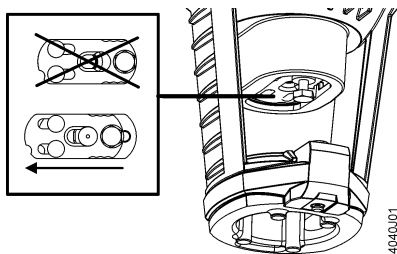

Figure 3.

2. Open the bonnet connection U-bracket. See Figure 4.

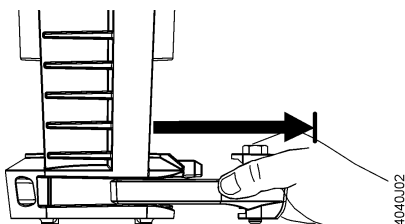

Figure 4.

3. Pull the valve stem to the fully extended position. Then, slide the actuator on the valve bonnet. See Figure 5.

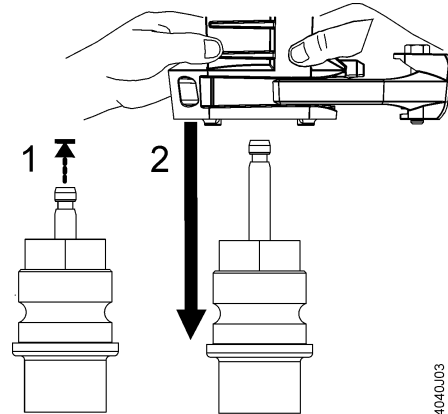

Figure 5.

4. Completely close the bonnet connection U-bracket. See Figure 6.

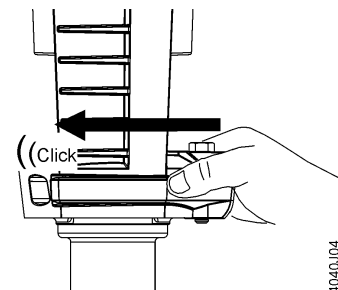

Figure 6.

NOTE: Position the actuator to accommodate the wiring. Hold the actuator in place while tightening the actuator U-bracket bolt.

5. Tighten the U-bracket bolt using a 10 mm wrench (or 4 mm hex wrench) to 5 Nm (44 in-lbs) torque. See Figure 7.

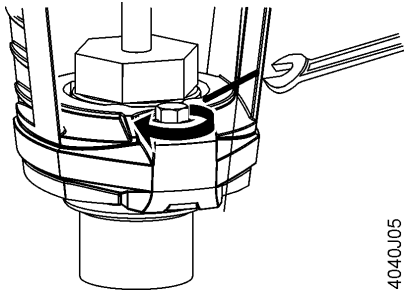

Figure 7.

6. Rotate the manual adjuster clockwise to manually extend the actuator shaft until it covers the head of the valve stem. See Figure 8.

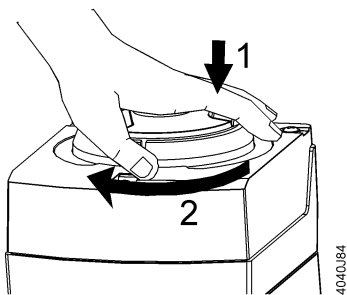

Figure 8.

7. Close the stem connection plate securely over the valve stem. See Figure 9.

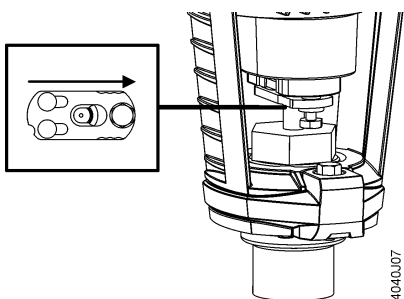

Figure 9.



CAUTION:

Do not rotate the actuator on the valve once the actuator and valve stem are connected. Doing so will inadvertently adjust the flow setting of the valve.

8. Secure the stem connection plate by tightening the bolt, using a 10 mm wrench (or 4 mm hex wrench). See Figure 10.

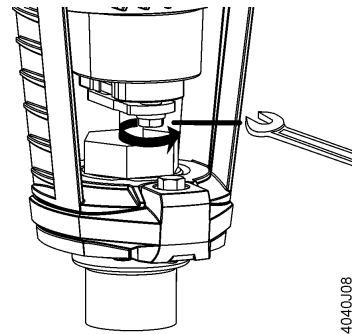

Figure 10.

The mounting is now complete.

Removing the actuator from a valve

1. Loosen the stem connection plate in the Valve Stem Coupling by loosening the bolt, using a 10 mm wrench (or 4 mm hex wrench).
2. Open the stem connection plate over the valve stem.
3. Manually retract the actuator shaft by turning the Manual Adjuster counterclockwise until it reveals the head of the valve stem.
4. Loosen the U-bracket using a 10 mm wrench (or 4 mm hex wrench).
5. Completely open the bonnet connection U-bracket.
6. Push the valve stem to the fully retracted position. Then, slide the actuator off the valve bonnet.
7. Remove the actuator from the valve, being careful not to damage the valve stem.
8. Close the bonnet connection U-bracket.

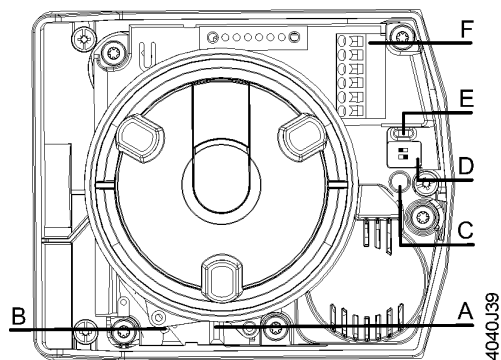

Figure 11. SAV Actuator with Cover Removed.

- A Plug-in space for Auxiliary switch ASC10.51.

- B Plug-in space for...
 - Function module AZX61.1 or
 - Auxiliary switch ASC10.51

- C LED

- D DIP Switches

- E Calibration Slot

- F Connection Terminals

Wiring

NOTE: All wiring must conform to national and local codes and regulations (NEC, CE, and so on).

Do not use autotransformers. Use earth ground isolating step-down Class 2 power supply transformers.

Determine supply transformer rating by summing total VA of all actuators used. The maximum rating for a Class 2 step-down transformer is 100 VA.

It is recommended that no more than 10 actuators are powered by one transformer.

Parallel Control of Actuators

Up to 10 actuators can be driven in parallel from a single controller output with a rating of 1 mA. Modulating actuators have an input impedance of 100KΩ.

NOTE: Use either a Phillips head screwdriver or a flat-blade screwdriver to remove the wiring compartment housing cover for access to the terminal block and DIP switches.

DIP Switch Setting

Switch 1: Control Signal







Select between 0 to 10 Vdc or 4 to 20 mA input signal for terminal Y (0 to 10 Vdc default).

Switch 2: Flow Characteristic

Do not change the flow characteristic switch from the default setting.

NOTE: Changing the default setting will modify the linear flow characteristic to: fast opening flow characteristic

Table 1. DIP Switch Settings.

Position	Positioning Signal "Y"	Position Feedback "U"	Flow Characteristic
OFF ¹⁾	 0 to 10 Vdc	 0 to 10 Vdc	 Default = Linear
ON	 DC 4 to 20 mA	 0 to 10 Vdc	 Modified = Fast Opening

1) Factory setting: All DIP switches are set to OFF.

Wiring

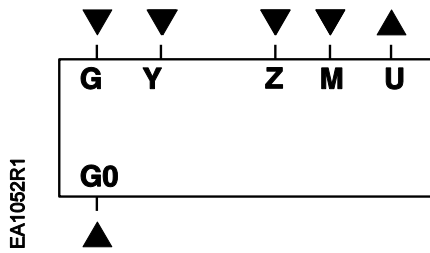

Figure 12. Connecting Terminals.

G0	System Neutral (SN)
G	System Potential (SP)
Y	Positioning signal for 0 to 10 Vdc/4 to 20 mA
M	Measuring neutral
U	Position feedback 0 to 10 Vdc
Z	Positioning signal forced control

Wiring Diagrams

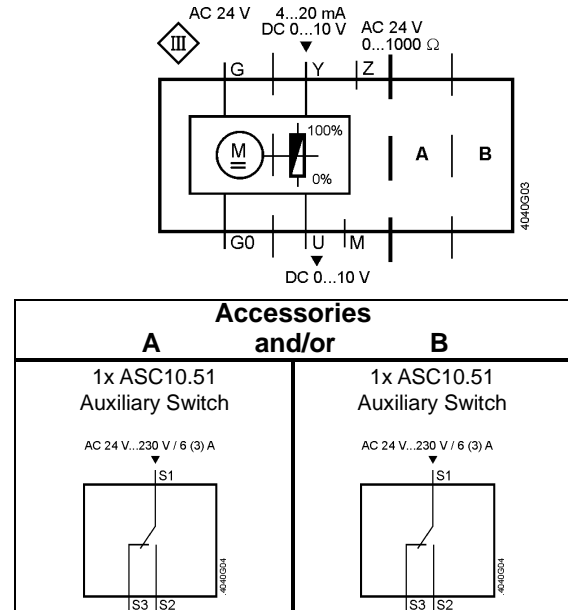

Figure 13. Applications.

The wiring diagrams show all possible connections. The application determines which connections are used. A and B are optional auxiliary switches.

Manual Override

Manual operation

When pushing the manual adjuster down (1), it engages and the actuator can be manually operated.

When turning the manual adjuster in a clockwise/counterclockwise direction (2), the actuator's stem extends/retracts. See Figure 14.

An overload protection prevents damage to the manual adjuster.

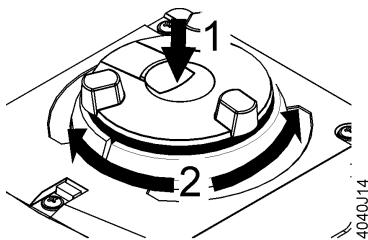

Figure 14.

Setting the position

Upon actuation and locking the slide switch (see Figure 15), the manual adjuster remains engaged.

When in this mode, do not turn the manual adjuster.

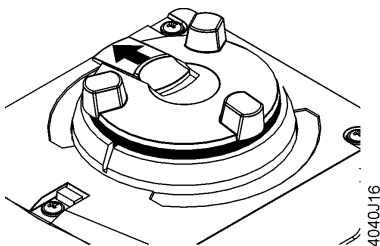

Figure 15.

Disengaging the setting

When resetting the slide switch (see Figure 16), the manual adjuster returns to Automatic Mode.

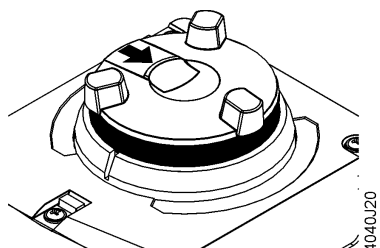

Figure 16.

Commissioning and Operation

Function Check and Calibration

Mechanical Check

Prior to making the function check, ensure that:

- Actuator is mechanically connected to a Siemens valve.
- Actuator is in Manual Operation mode.

The actuator can be operated with the help of the Manual Adjuster.

Manual Adjuster Action	Actuator Response
Turning in clockwise direction	Actuator's stem extends
Turning in counter-clockwise direction	Actuator's stem retracts

NOTE: Ensure that the actuator's and valve's stems are securely connected in all positions.

If the actuator is forced to travel beyond its end positions, overload protection responds.

Electrical Check

Prior to making the function check, ensure that:

- Actuator is mechanically connected to a Siemens valve.
- Actuator is in Automatic Operation mode.
- Actuator and, if required, accessories are correctly fitted and connected.
- Power is applied.

Calibration

Calibration is required with modulating actuators, and before the function check.

NOTE: Calibration must be performed manually.

Prior to calibrating, ensure that:

- Actuator is properly connected to a valve.
- Housing cover is removed.
- Power is applied.

If required, calibration can be repeated any number of times.

To initiate the calibration process insert a flat-blade screwdriver into the calibration slot to short out the two sides of the slot. See Figure 17.

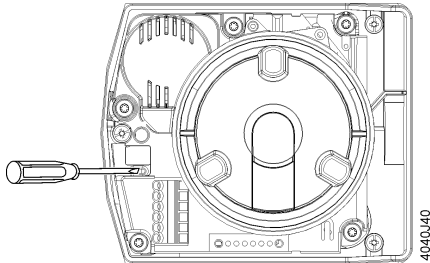
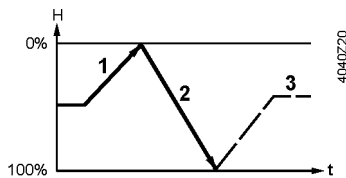

Figure 17. Step 1—Bridge contact.

During calibration, the actuator detects the valve's end positions and files the exact stroke in its internal memory. Calibration takes place in three phases:



- Actuator drives to H_0 (1), retracting actuator stem. Detection of upper end position.
- Actuator drives to H_{100} (2), extending actuator stem. Detection of lower end position.
- The detected values are stored (3). Then the actuator follows the applied control signal.

Observe the status indication (LED) during and after calibration. See Figure 18 and Table 2.

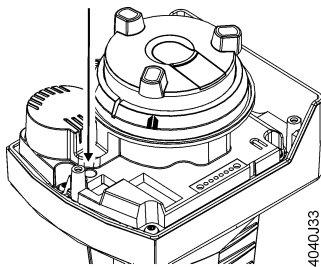

Figure 18. Step 2—Check LED.

Table 2. LED Indication and Status.

LED	Indication	Operating state	Remarks, troubleshooting
Green	On	Automatic mode	Normal operation
	Blinking	Calibration	Wait until calibration is finished (then green or red light)
		In manual mode	Manual adjuster in MAN position
Red	On	Calibration error	Start calibration again
	Blinking	Detection of foreign object	Check valve / actuator
Off	Off	No power or electronics faulty	Check operating voltage

If the actuator does not detect the second end position within an appropriate stroke range (max. 25 mm), the first end stop will be adopted, and the actuator operates with a working range of 20 mm.

Function Check

Perform the function check for modulating actuators after calibration with a point test according to the following table:

Table 3. Modulating Function Check.

Connection Terminals	Actuator Response	Position Feedback (U)
Y 6V 13.6 mA	Actuator's stem extends (60%)	6V
Y 5V 12 mA	Actuator's stem retracts (50%)	5V
"Z" connected to "G"	Actuator's stem extends to 100%	10V
"Z" connected to "G0"	Actuator's stem retracts to 0%	0V

After successful completion of the function check, the actuator is ready for normal operation.

References

Technical Instructions:

155-547
 SAV Electronic Valve Actuator
 Non-Spring Return, 24 Vac/dc, Proportional Control

Dimensions

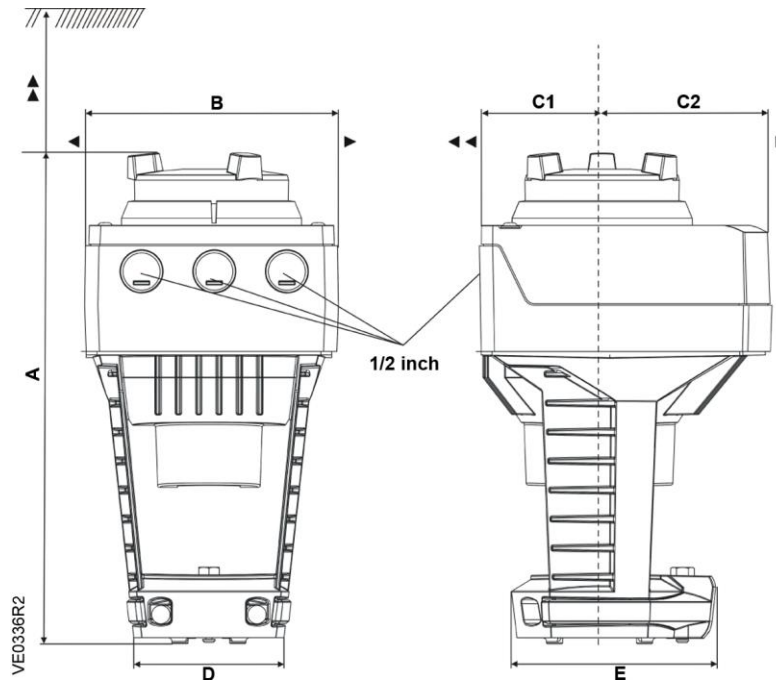

Product Number	A	B	C	C1	C2	D	E	▶	▶▶	Weight lbs (kg)
SAV61.00U	10.43 (265)	4.88 (124)	5.91 (150)	2.68 (68)	3.23 (82)	3.15 (80)	3.94 (100)	3.94 (100)	7.87 (200)	4.23 (1.92)
With ASK39.1	11.42 (290)	6.06 (154)	11.81 (300)	7.87 (200)	3.94 (100)	–	–	–	–	4.74 (2.15)

Figure 19. SAV Dimensions in Inches (Millimeters).

Information in this publication is based on current specifications. The company reserves the right to make changes in specifications and models as design improvements are introduced. Product or company names mentioned herein may be the trademarks of their respective owners. © 2022 Siemens Industry, Inc.