

PL-Link Semi-Flush-Mount Room Sensor Kits

Product Description

Siemens PL-Link Semi-Flush Mount Room Sensors measure and transmit room temperature, humidity, and CO2 data to a DXR Controller.

Sensors are offered as kits consisting of a base module, front module and trim frame. Individual components are also available as replacement parts.

NOTE: These sensors are designed for installation in a vertical 2" x 4" electrical box. Other installation types are not recommended.



Figure 1. Semi-Flush Mount Room Sensor.

Expected Installation Time

25 minutes

Required Tools

- ABT Site or ABT Pro
- OCI702 KNX to USB interface (order Siemens Part Number S55800-Y101)
- Small Phillips screwdriver
- Small flat-blade screwdriver
- (2) No. 6 x 1-1/4 Phillips panhead screws for mounting to electrical box

Prerequisites

- Review these instructions before beginning.
- Ensure that appropriate field wiring is installed in accordance with KNX standards.

NOTE:

All wiring must comply with applicable building codes and regulations.

Product Numbers

Kit Number	Kit Part Number and Components			Measured Values		
	Base Module	Front Module	Frame	CO ₂	RH	Temp
QAA2570.2532	AQR2570NJ	AQR2532NNW	AQR2510NGW	N/A	N/A	•
QFA2570.2535	AQR2570NJ	AQR2535NNW	AQR2510NGW	N/A	•	•
QPA2576.2535	AQR2576NJ	AQR2535NNW	AQR2510NGW	•	•	•

Mounting and Electrical Installation

Mounting Location

- Locate sensor approximately 5 feet (1.5 m) above floor level and at least 1.75 feet (50 cm) from adjoining walls.
- Do not install on outside wall, behind curtains, near heating/cooling sources, or where exposed to direct sunlight.

Installation Procedure

1. Install base module (A) in the electrical box and use the No. 6 x 1-1/4 screws (provided) to attach the mounting plate (B) to the box.
2. Position the trim frame (D) appropriately over the base module.
3. To deter theft or vandalism of front module, use the red anti-theft device (C) supplied with the front module as shown below.
4. Carefully snap the front module into the base module while holding the frame in position.
 The anti-theft device can be unlocked by carefully inserting a small flat-blade screwdriver into the bottom ventilation slot on the front module.

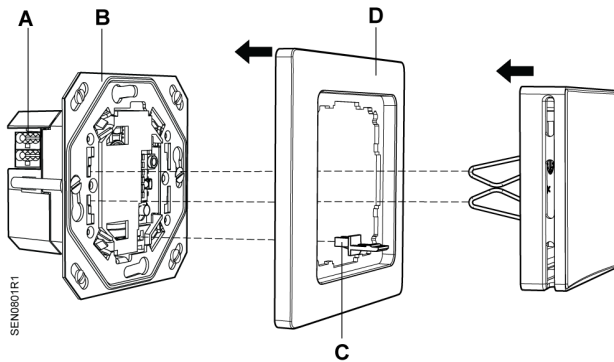

Figure 2. Sensor Kit Installation.

Electrical Installation

- Ensure that the bus wiring complies with the KNX standards.
- Comply with all applicable regulations.
- Connect wiring as follows:

Terminals	Description
CE+; CE-	PL-Link Bus (Do not cross wires)
DI1	Digital Input 1
DI2	Digital Input 2
B; M	Remote Sensor Input (10K Ohm Type II)

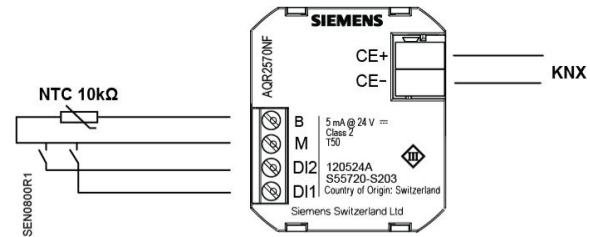

Figure 3. Electrical Connections.

Address Labels

These devices are supplied with peel-off adhesive address labels containing the unique KNX ID as an alphanumeric and barcode display.

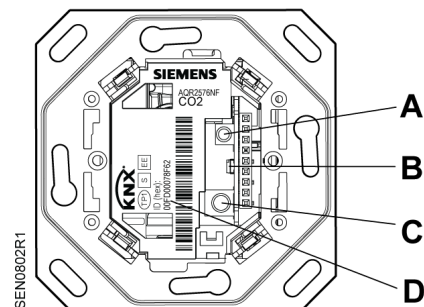

Figure 4. Address Label.

To simplify the commissioning process, this label can be removed from the sensor and affixed to the appropriate location on the building floor plan drawing. If the adhesive label is misplaced, the device ID number is also printed on the base module.

Engineering and Commissioning

Below are the location and functions of important commissioning elements on the front of the base module:



- A. Tool connection plug C. Programming button
 B. Status LED D. KNX ID number

Pushbutton Actuation	Result
Short (< 0.5 s)	Switch to programming mode or acknowledge display of a connection test.
Medium-long (> 2 s and < 20 s)	Initiate connection test.
Long (> 20 s)	Reset to factory settings.

LED Indication	Meaning
Off	Device is not connected to power, or device is powered and is working as intended.
Single orange flash	Feedback when pressing button > 2 seconds.
Continuous orange flash	Connection test or reset to factory default in process.
Flashing red	Connection test failed.
Red	Device is in programming mode.
Green	Connection test successful.

Recommended Engineering Workflow

The following engineering workflow is recommended to optimize the functionality of the PL-Link flush-mount room sensors:

1. The Design Engineer plans the system using the ABT tool. The planning data for the entire project are saved to the engineering data server.
2. The Electrical Installer installs the flush-mount room sensor, peels off the address labels from the devices and sticks them to a floor plan or similar plan. The floor plan is then returned to the Planning Engineer who uses the floor plan to complete the planning data (assignment of room sensor as per actual addresses in ABT).
3. The Design Engineer can now pre-configure the DXR offline in ABT:
 - a. Add the required number of room sensors, the KNX PL-Link bus of an automation station, and the configuration dialog of the individual room sensor.
 - b. Enter the KNX ID alphanumerically.

This configuration is then compiled into a Pack & Go file for upload into the automation station at the installation location.

4. The Design Engineer sends the Pack & Go file to the Electrical Installer.
5. The Electrical Installer uploads this file into the automation station and runs initial tests using the SSA tool.
6. The Commissioning Engineer uses the planning data and ABT to complete commissioning.

Commissioning

Prior to commissioning, all devices must be mounted per the mounting instructions and connected to bus wiring. If available, pushbuttons and external temperature sensors must also be connected to the device. Bus wiring must be tested.

For plug and play commissioning, the automation station must be set up following the *Recommended Engineering Workflow*.

The automation station is powered and connected to the bus. The room sensors are disconnected from power.

- Apply power to all room sensors (concurrently or by device).
- The automation station and room sensor(s) register and assign the addresses. Configuration data is transmitted from the controller to the room sensors.
- *(Optional)* Test the connection using medium-long pushbutton actuation (> 2 s and < 20 s).

Installation is now complete.

Information in this publication is based on current specifications. The company reserves the right to make changes in specifications and models as design improvements are introduced. Product or company names mentioned herein may be the trademarks of their respective owners. © 2016 Siemens Industry, Inc.