

Pressure Independent Control Series Rack & Pinion Actuators

Product Description

These installation instructions describe the steps for mounting the Pressure Independent Control Series Rack & Pinion Actuators (Figure 1), including the:

- linkage and actuator assembly
- linkage only

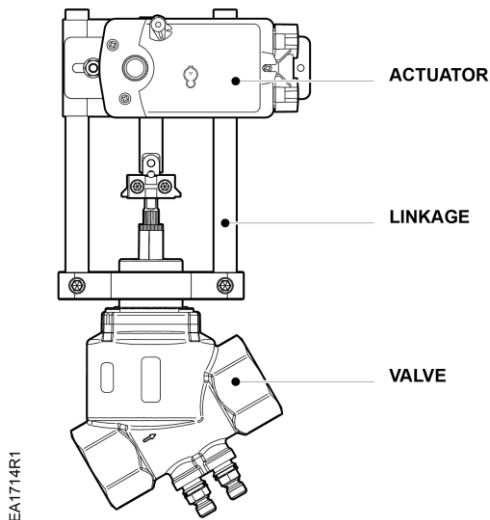

Figure 1. Parts of the Pressure Independent Control Series Rack & Pinion Actuator.

Product Numbers

Product Number	Description
599-03615	Linkage only
599-03615 + GPC131.1P	Linkage and OpenAir® GPC131.1P Electronic Actuator for 3-position control
599-03617NO 599-03617NC	Assembly consisting of: linkage and OpenAir GPC161.1P Electronic Actuator (337) assembly for modulating control
337NO-xxxx-xx 337NC-xxxx-xx	Assembly consisting of: linkage, actuator, and valve. (See <i>Pressure Independent Control Series 2-Way Valves and Electronic Valve Actuators Submittal Sheet</i> , 154-087 for details and product numbers.)

Warning/Caution Notations

WARNING		Personal injury or loss of life may occur if you do not perform a procedure as specified.
CAUTION		Equipment damage or loss of data may occur if you do not follow a procedure as specified.

Required Tools

- 3 mm hex key
- 5 mm hex key
- 1/4-inch hex key

Expected Installation Time

30 minutes: Linkage and actuator assembly to valve (preload time included)

Prerequisites

The actuators are preloaded at the factory. If the actuator preload is lost, the preload must be reset according to the *Preload the Actuator* section.



WARNING:
Do not open the actuator.

NOTES:

- For Linkage only (599-03615) installation, follow all steps in these Installation Instructions.
- For Rack and Pinion Linkage and Actuator Assembly (599-03617Nx) installation, see *Mounting the Linkage on a Valve and Preload the Actuator*.

Mounting the Linkage on a Valve

1. Use the 5 mm hex key to loosen the screws in the linkage stem coupling. Use the 1/4-inch hex key to loosen the screws in the linkage yoke. See Figure 2.

NOTE: Do not remove the screws in the linkage stem coupling or in the linkage yoke.

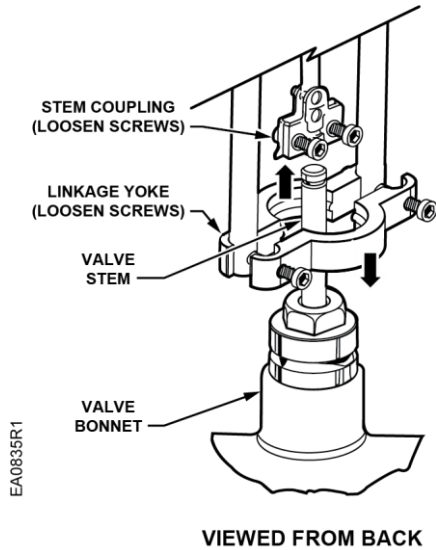

Figure 2. Mounting the Linkage/Actuator Assembly on a Valve.

2. Orient the linkage over the valve bonnet. See Figure 2.
3. Align the valve stem with the linkage stem coupling. See Figure 3.

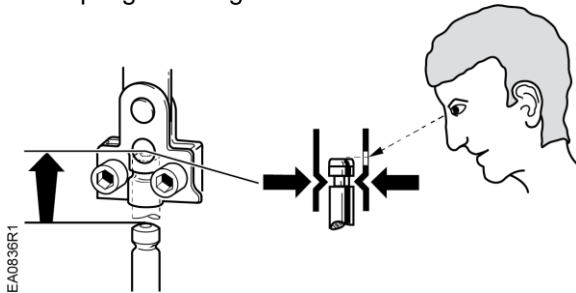

Figure 3. Proper Alignment of the Valve Stem to the Linkage Stem Coupling.

4. Insert the valve stem into the linkage stem coupling. See Figure 3.
5. Use the 5 mm hex key to tighten the stem coupling screws to 35 lb-in. (4 Nm), and to secure the connection to the valve stem. See Figure 4.

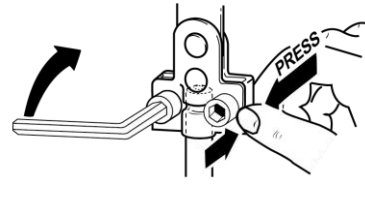

Figure 4. Connecting the Linkage Stem Coupling on the Valve Stem.

6. Use the 1/4-inch hex key to tighten the screws to 65 lb-in. (7 Nm) in the linkage yoke and to secure the linkage on the valve bonnet. See Figure 5.

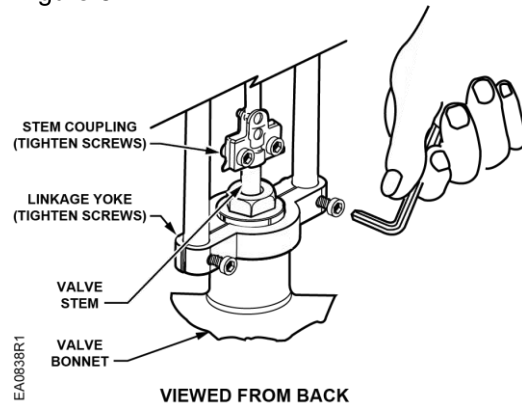

Figure 5. Connecting the Linkage Assembly on the Valve.

Assemble Actuator to the Linkage

1. Determine if Normally Open or Normally Closed control is needed.
2. Proceed with the *Normally Open Control Applications* or *Normally Closed Control Applications* section as appropriate.



CAUTION:

Ensure that three rubber bumpers (acting as spacers) are in place (see Figure 6). If missing or damaged allow 5/16" space between the bottom of the actuator and the mounting plate. Mount the actuator parallel to the mounting plate.

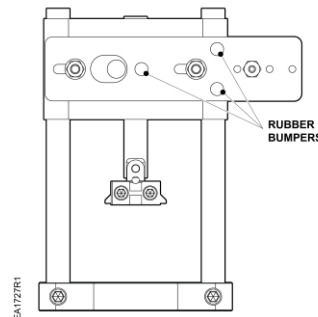

Figure 6. Location of Rubber Bumpers.

Normally Open Control Applications (Figure 7)

1. Ensure that the shaft adapter is connected to the darker-colored side of the actuator.
2. Orient the actuator so that the gear train lockpin is on the top.
3. Loosen the shaft adapter locking screw (if necessary). Align the actuator over the linkage shaft and insert the anti-rotation piece into the notched mounting hole on the back of the actuator.
4. Continue with the *Preload the Actuator* section.

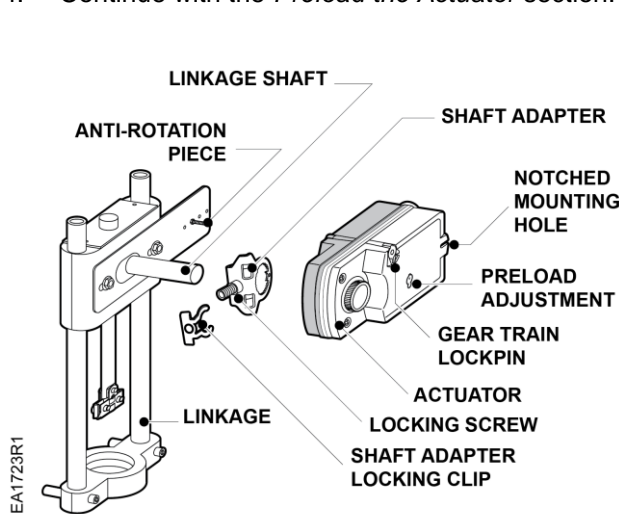

Figure 7. Mounting Actuator on Linkage for Normally Open Control Application.

CAUTION: When mounting the actuator shaft adapter to the linkage, the shaft adapter must be between the linkage and the actuator. This ensures proper alignment and prevents actuator damage.

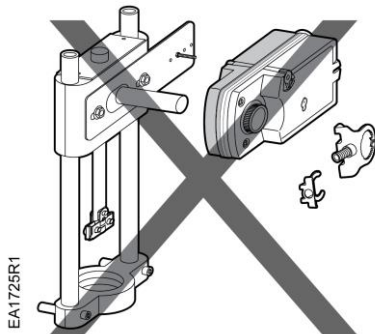

Figure 8. Incorrect Mounting for Normally Open Control Application.

Normally Closed Control Applications (Figure 9)

1. Ensure that the shaft adapter is connected to the lighter-colored side of the actuator.
2. Orient the actuator so that the gear train lockpin is on the bottom.
3. Align the actuator over the linkage shaft and insert the anti-rotation piece into the notched mounting hole on the back of the actuator.
4. Continue with the *Preload the Actuator* section.

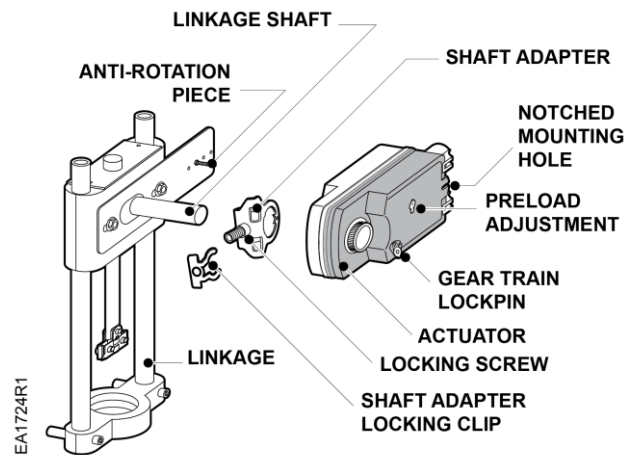

Figure 9. Mounting Actuator on Linkage for Normally Closed Control Application.

CAUTION: When mounting the actuator shaft adapter to the linkage, the shaft adapter must be between the linkage and the actuator. This ensures proper alignment and prevents actuator damage.

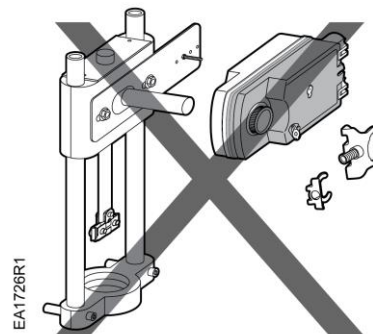

Figure 10. Incorrect Mounting for Normally Closed Control Application.

Preload the Actuator

NOTE: The actuators are preloaded at the factory. If the actuator preload is lost, the preload can be reset using the following instructions.

Normally Open Control Application

1. Ensure that the valve stem is in the full **UP** position.
2. Use a 3 mm hex key to tighten the shaft adapter locking screw to 44 to 62 lb-in. (5 to 7 Nm).

Normally Closed Control Application

1. Ensure that the valve stem is in the full **UP** position.
2. With the shaft adapter locking screw loose, open the rubber cover and insert the 3 mm hex key in Manual Override opening (Figure 9).
3. Preload the actuator by turning the hex key counterclockwise until the end stop is met (at least 12 turns if turning slowly), and then back it off clockwise 1/2 turn. Hold the hex key in place.
NOTE: Always turn the hex key in the direction of the actuator hand symbol arrow.
4. Engage the gear train lockpin. Release the hex key, then release the gear train lockpin. The lockpin should be in the STOP position.
5. Use a 3 mm hex key to tighten the shaft adapter locking screw to 44 to 62 lb-in. (5 to 7 Nm).
6. Unlock the hex key by pushing slightly in the clockwise direction of the arrow. The preload is now set.
7. Remove the 3 mm hex key from the preload adjustment.

Installation

Mount the Linkage/Actuator/Valve Assembly as shown in Figure 11 and in the location per job drawings.

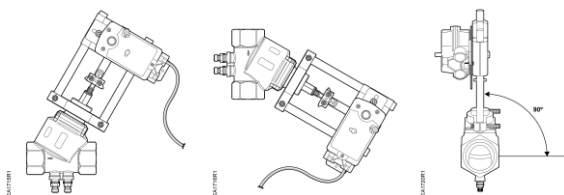

Figure 11. Acceptable Mounting Positions.

NOTE:

Remove the zip tie and discard.

The installation is now complete.

Wiring

All wiring must conform to NEC, and local codes and regulations.

Use earth ground isolating step-down Class 2 transformers. Do not use auto transformers.

Determine the supply transformer rating by summing the total VA of all actuators used. The maximum rating for a Class 2 step-down transformer is 100 VA.

Table 1. Floating Actuator Operation.

Operation	Valve Motion When Control Signal Y1 is Energized	Valve Motion When Control Signal Y2 is Energized
NO	Closes	Opens
NC	Opens	Closes

Table 2 shows the recommended maximum actuators per Class 2 circuit and includes a safety factor of 80% of the transformer VA. Operating additional actuators requires additional transformers or separate 100 VA power trunks.

Table 2. Recommended Maximum Power Consumption (VA) for a Class 2 Step-Down Transformer.

Actuator	Power Consumption	Actuator per Class 2 Supply Circuit
GPC131.1P	3.5 VA	23
GPC161.1P	3.5 VA	23

References

Document Title	Document Number
<i>Pressure Independent Control Series Rack & Pinion Actuators, Technical Instructions</i>	A6V11637981
<i>Pressure Independent Control Series 2-Way Valves and Electronic Valve Actuators Submittal Sheet</i>	154-087

Wiring Diagrams

599-03617 Assembly (with GPC161.1P) for Modulating Control with 24 Vac or 24 Vdc Supply Voltage

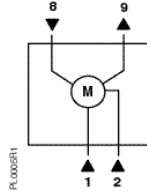

Table 3. 599-03617 Assembly (with GPC161.1P) for Modulating Control.

Standard Symbol	Function	Terminal Connection	Standard Color
1	Supply (SP)	G	Red
2	Neutral (SN)	G0	Black
8	0 to 10 Vdc input signal	Y	Gray
9	Output for 0 to 10 Vdc position feedback indication	U	Pink

599-03515 + GPC131.1P for 24 Vac or 24 Vdc Three-position Floating Control

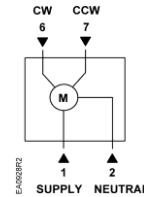

Table 4. 599-03515 + GPC131.1P for Three-position Floating Control.

Standard Symbol	Function	Terminal Connection	Standard Color
1	Supply (SP)	G	Red
2	Neutral (SN)	G0	Black
6	Control signal clockwise	Y1	Violet
7	Control signal counterclockwise	Y2	Orange

Dimensions

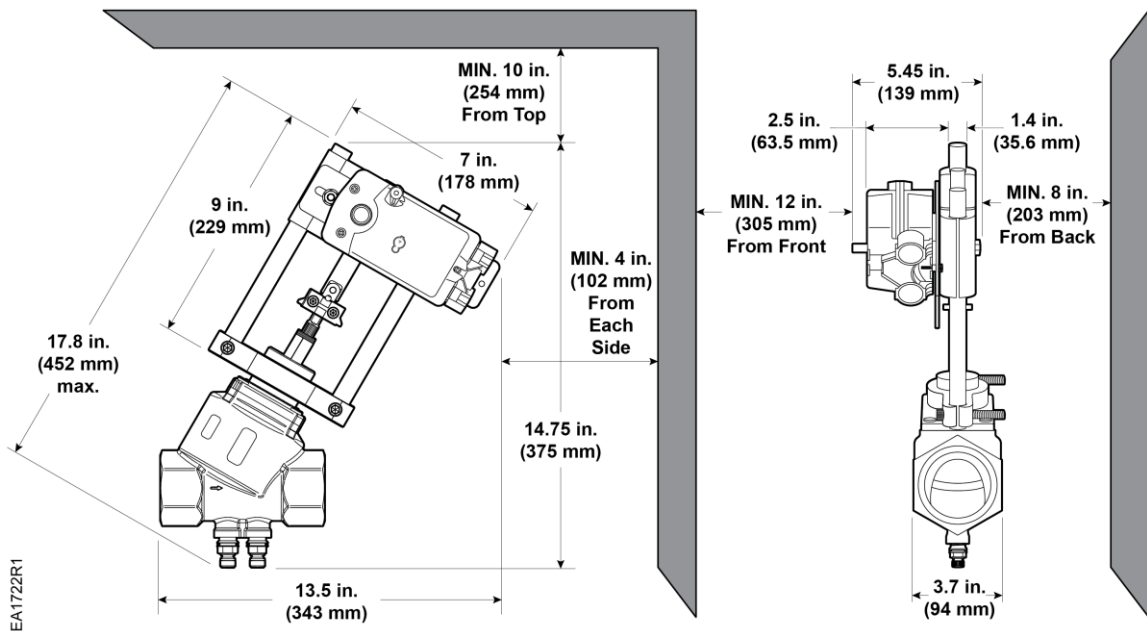

Figure 12. Dimensions of the Pressure Independent Control Series Rack & Pinion Actuator in Inches (Millimeters).

Information in this publication is based on current specifications. The company reserves the right to make changes in specifications and models as design improvements are introduced. Products or company names mentioned herein may be the trademarks of their respective owners. © 2019-2022 Siemens Industry, Inc.