

SIEMENS



A-Series Electric Actuator (600 to 18,000 lb-in) Installation, Operation, and Maintenance Manual

Table of Contents

Introduction	5
Safety.....	5
Heater	5
Principle of Operation	6
Electrical Operation	6
Mechanical Operation.....	7
Storage	8
Actuation	9
Manual Operation	9
Remote Operation	9
A-Series On/Off Actuator with Interposing Relay Board (IRB)	10
Servo NXT	11
Mounting the Actuator	13
Commissioning	14
Wiring the Actuator	14
Setting Travel Limit Switches	14
Setting Mechanical Travel Stops	16
Field or Factory-Installable Options	18
Auxiliary Switches.....	18
Torque Switches (13K and 18K Only)	18
External Signal Feedback Potentiometer	19
Feedback Potentiometer Kit.....	19
Required Tools	19
Installation Instructions.....	19
Basic Tools	21
Troubleshooting	22
A-Series 24V On/Off Electric Actuator	23
Safety.....	23
Heater	23
Actuation.....	24
Manual Operation.....	24
Remote Operation	25
Commissioning	25
Wiring the Actuator.....	25
Setting Travel Limit Switch Cams	26
Setting Mechanical Travel Stops.....	28
Configuring Your 24V On/Off Controller.....	29
DIP Switch Setting.....	29

Field or Factory-Installable Options.....	31
Auxiliary Switches	31
Basic Tools	31
Troubleshooting.....	32
Troubleshooting Guide.....	32
Actuator Troubleshooting Chart	32
Troubleshooting Example	33
A-Series Servo NXT Modulating Controller	34
Safety.....	34
Description of Operation.....	34
User Interface	35
Product Settings	35
Changing Settings	36
Description of Settings	37
Motor Stall Detection	40
Operating Modes.....	41
Remote Mode	41
Local Mode	41
Manual Mode	41
Autocalibration Mode	41
Status Indication.....	42
Valve Position	42
Fault Status.....	42
Status Indicator	43
Hardware Description	43
Terminal Connections	43
Power	44
Heater	44
Motor	44
Input Signal	45
Output Signal	45
Feedback Potentiometer.....	45
Handwheel	45
Torque Switch	46
Limit Switch.....	46
Quick Start Guide	46
Troubleshooting Guide	47

Introduction

The A-Series quarter-turn industrial electric actuator features a compact, reliable design that mounts directly to Siemens resilient seat butterfly valves without the need for brackets and linkages. Available in torque outputs from 600 to 18,000 lb-in (68 to 2,033 Nm), 24V and 120 Vac, Two-position (On/Off) and Modulating units all in NEMA 4x and IP65-rated housings.

Safety

This device left the factory in proper condition to be safely installed and operated in a hazard-free manner. The notes and warnings in this document must be observed by the user to ensure hazard-free operation of this device.

All necessary precautions must be taken to prevent damage due to rough handling, impact, or improper storage. Do not use abrasive compounds to clean the device, or scrape its surfaces with any objects.

Configuration and setup procedures for this device are described in this manual. Proper configuration and setup are required for the safe operation of this device.

The control system in which this device is installed must have proper safeguards to prevent injury to personnel, or damage to equipment, should a failure of system components occur.



⚠ WARNING

Installation, commissioning, operation and maintenance of the unit must be performed under strict observation of all applicable codes, standards, and safety regulations.

The actuator must only be installed, commissioned, operated and repaired by qualified personnel. A qualified person is one who is trained in:

- The operation and maintenance of electrical equipment and systems in accordance with established safety practices.
- Procedures to energize, de-energize, ground, tag and lockout electrical circuits and equipment in accordance with established safety practices.
- The proper use and care of personal protective equipment (PPE) in accordance with established safety practices.
- First aid.

This document does not cover every detail about every version of the product described. It does not consider every potential occurrence concerning the installation, operation, maintenance and use of this device.

If situations transpire that are not documented in sufficient detail, please request the required information from the Siemens Distributor or Representative responsible for your area.

Heater

All A-Series electric actuators include a heater to prevent condensation from forming inside the actuator. This PTC (Positive Temperature Coefficient) style heater has a unique temperature-resistance characteristic. The heater self-regulates by increasing its electrical resistance relative to its temperature. The heater does not require external thermostats or switches to control its heat output.

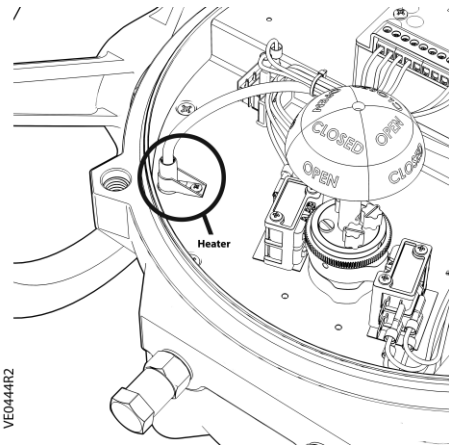

Figure 1: Heater Installed on an A-Series Actuator Switch Plate.



NOTE:

The heater must have constant power supply to be effective.



⚠ WARNING

The heater surface can reach temperatures in excess of 392°F (200°C).

Principle of Operation

The A-Series actuator is divided into two internal sections, the power center below the switch plate, and the control center above the switch plate. Below the switch plate, the gear motor, with its spur gear train, drives a non-backdriveable worm gear output. The override mechanism for manual operation is also housed here. Above the switch plate is where user-required readily accessible components are placed. The indicator shaft assembly, limit switches, terminal strips, heater, and electronic controllers are all placed here for easy access.

External to the unit are adjustable mechanical travel stops, a large and easy-to-read indicator, the unique manual override handwheel, and dual conduit entry ports. The external coating is a high-quality Epoxy coat with polyurethane finish which has exceptional UV protection and chemical resistance.

Electrical Operation

The gear motors used in the A-Series actuator are of either permanent split capacitor (PSC) design (single phase AC power) or permanent magnet (PM) design (DC power). Travel limit switches are mechanical form (SPDT) with contacts rated at 10 Amp (0.8 PF), 1/2 HP 125/250 Vac.

In cases where the torque capacity of the unit is exceeded to the point where the motor stalls, a thermal protector switch, built into the PSC motor windings, will automatically disconnect the motor power and prevent overheating. Once the motor cools sufficiently, the thermal protector switch will reset automatically.

Mechanical Operation

Mechanically, the ratio of the gear motor determines the speed of the unit. The gear motor utilizes high efficiency spur gears with various ratios for the different speeds. Initial gear reduction through the spur gears is then transferred to the worm shaft. The final gear reduction and output is through a non-backdriveable worm gear set. Positioning is determined by an indicator/cam shaft, which is linked to the output shaft. In the declutchable condition, the manual override drives the worm shaft when engaged.

Storage

**⚠ CAUTION**

Actuators are not weatherproof unless they are properly installed on the valve or prepared for storage. Siemens cannot accept responsibility for deterioration caused on-site.

- Store units on a shelf or wooden pallet to protect against floor dampness.
- Cover the units to protect against dust and dirt.
- Maintain a near constant external temperature to prevent condensation from forming inside these units and store in a well-ventilated, clean, dry room away from vibration.
- Power should be supplied to the heater through a conduit entry with an appropriate sealing gland.

Actuation

Manual Operation

The manual override operates like a watch adjusting knob. To engage the manual override, simply pull the handwheel to its outermost position. A yellow stripe is revealed to visually indicate manual override engagement as shown below. The two handwheel positions, engaged and disengaged, are held in place with the use of spring plungers. The handwheel remains in position until physically moved.

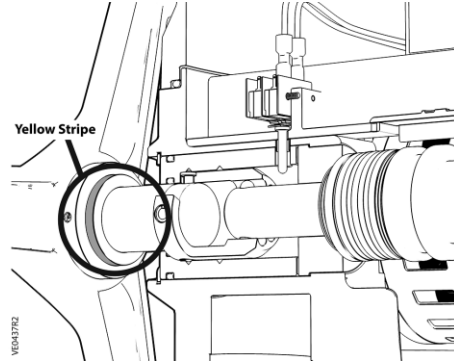

Figure 2: Engaged Handwheel Showing Yellow Stripe.

Once the manual override is engaged, rotate the handwheel in the clockwise direction to rotate the output shaft in the clockwise (close) direction and vice-versa.

To disengage the manual override, push the handwheel towards the actuator until the yellow stripe is hidden.



CAUTION

A label on the handwheel hub warns users not to exceed a specific “rim pull” force, for each size of actuator.

If the “rim pull” force is exceeded, the roll pin securing the handwheel onto the manual override shaft is designed to shear, which prevents serious internal gearing damage.

Remote Operation



CAUTION

- Verify that the main electric power supplied to the actuator is in compliance with the specifications on the actuator label.
- Engaging the handwheel before or during the application of a supply voltage will prevent the actuator motor from operating.
- If torque switches are installed in the actuator, an over-torque condition will prevent the actuator motor from operating in the direction of fault.

A-Series On/Off Actuator with Interposing Relay Board (IRB)

The back feeding of one actuator by another one wired in parallel is eliminated by using the IRB. If the actuator is running **Open** and the user switches “instantaneously” to run **Closed**, the **Open** relay will take time to ‘drop-out’ and the **Close** relay will take time to ‘pull-in’. This time lapse is ~ 40 ms. The time delay provided by the IRB will protect the switches and gears from the controller’s instantaneous command signal reversal. Current draws and field wirings are not affected by adding IRB.

Series A 120 Vac IRB, auxiliary switch, heater, and torque switch option are UL-certified units.



NOTE:

The host controller should use a one-second time delay for command signal reversal.



CAUTION

Apply voltage to only one direction terminal at a time.

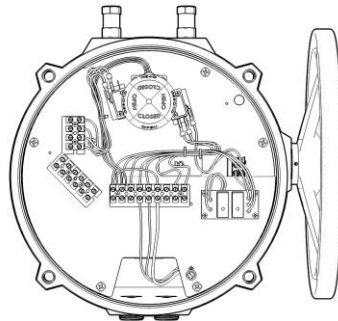

VE0445R1

Figure 3: A-Series Actuator with I.R.B.

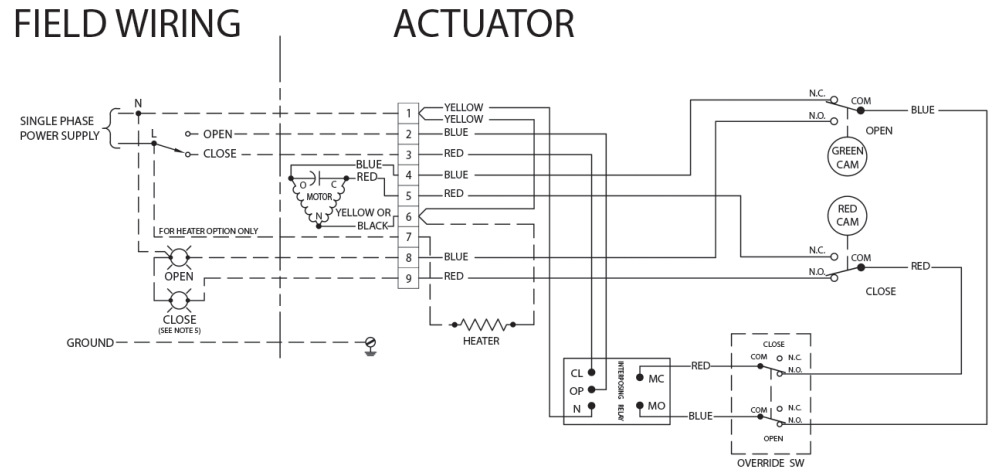

VE0446R2

Figure 4: Sample Wiring Diagram for A-Series Actuator with I.R.B.

Servo NXT

To control the actuator remotely from a process controller in a modulating application, the user must apply the proper supply voltage and the configured control signal to the Servo NXT electronics package. The control signal may be applied locally from a hand-held signal generator or remotely from a process controller.

For more information, see the *A-Series Servo NXT Modulating Controller* section.

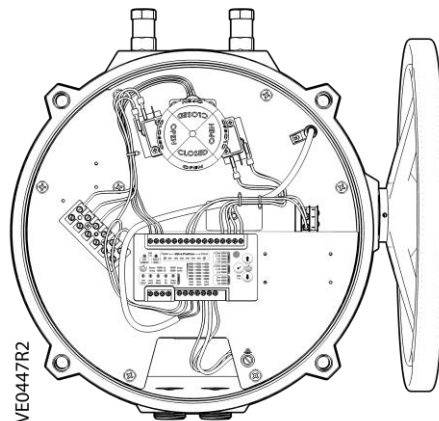

VE0447R2

Figure 5: A-Series Actuator with Servo NXT.

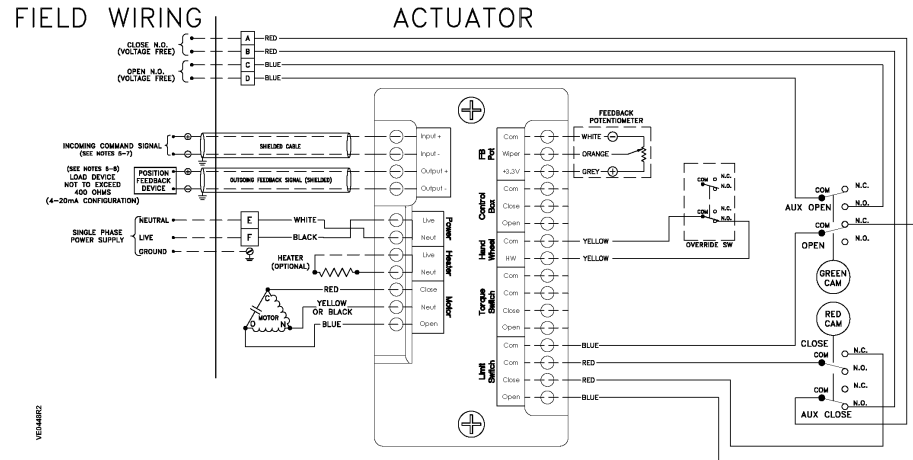

Figure 6: Sample Field Wiring Diagram for A-Series Actuator with Servo NXT.

Mounting the Actuator

All A-Series electric actuators are suitable for direct mounting on Siemens resilient seat butterfly valves. With proper mounting hardware, the A-Series actuator can be installed onto other quarter-turn valves or devices.

!	<p>NOTICE</p> <ul style="list-style-type: none"> • The standard mounting position for the actuator orients the unit with its handwheel in a vertical plane and parallel to the pipeline. • If the actuator is mounted on a vertical pipe, it is recommended that the unit be positioned with the conduit entries on the bottom to prevent condensation from entering the actuator through its conduits. • In all cases, the conduit should be positioned to prevent drainage into the actuator and the handwheel should not be facing down.
----------	---

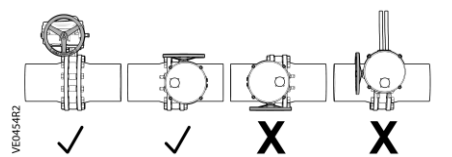

Figure 7: Horizontal Mounting Positions.

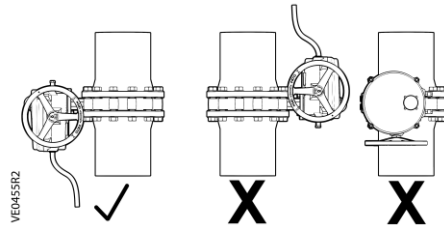

Figure 8: Vertical Mounting Positions.

Follow the steps below to mount the actuator onto the valve .

1. Manually operate the actuator until the output shaft of the actuator is in line with the valve stem. If possible, select an intermediate position for both the valve and actuator.
2. If required, place the proper adapter onto the valve stem. It is recommended that a small amount of 'anti-seize' lubricant be applied to the adapter to ease assembly.
3. Mount the actuator onto the valve stem.
4. Install the furnished mounting studs by threading studs all the way into the actuator base. It may be necessary to manually operate the actuator to align the valve and actuator bolt patterns.
5. Fasten the mounting studs in place with furnished hex nuts and lock washers.

Commissioning

Wiring the Actuator



⚠ WARNING

Turn off all power and lockout/tag out service panel before installing or modifying any electrical wiring.

1. Remove the actuator cover. Keep the cover on hand for reference.
2. Wire the actuator according to the wiring diagram attached to the inside of the actuator cover.



NOTICE

- Power and control wiring should use separate conduit entries.
- A minimum of 18 AWG wire is recommended for all field wiring.
- Terminals directly mounted on the actuator switch plate accept wire sizes ranging from 14 to 22 AWG.
- Terminals of internally-mounted electronics modules accept wire sizes ranging from 14 to 24 AWG.
- The conduit connections must be properly sealed to maintain the weatherproof integrity of the actuator enclosure.



⚠ CAUTION

When wiring an A-Series Industrial Electric Actuator for two-position (On/Off) control: If the power to the actuator is commanded to be off, you must ensure that there is no extraneous or leakage voltage between hot and common. Leakage voltage greater than 3 Vac can cause actuator failure.

The controller should use at minimum, a one-second time delay for command signal reversal. Instantaneous command reversals may cause actuator failure.

Setting Travel Limit Switches



NOTICE

If the unit came assembled to a valve, the switches have been factory-set and DO NOT need adjustment.

A-Series actuators use a cam design along with two SPDT mechanical switches to set the **Open** and **Closed** positions of the valve.

The green cam actuates the 'open' switch when the actuator reaches the **Open** position. Similarly, the red cam actuates the 'closed' switch when the actuator reaches the **Closed** position.

Standard factory setting of the travel limit switches allows 90° travel between the **Open** and **Closed** positions. Cams for each switch are adjustable for applications where less than 90° travel is desired between the **Open** and **Closed** positions.

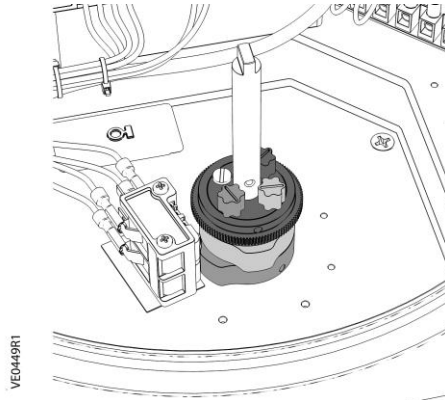

Figure 9: Two SPDT Travel Limit Switches.

Complete the following steps to adjust the travel limit cams:



NOTE:

For Actuators Axxx.13K and Axxx18K, skip Steps 1 and 10.

1. Remove the indicator rotor by pulling it away from the indicator shaft as shown below.

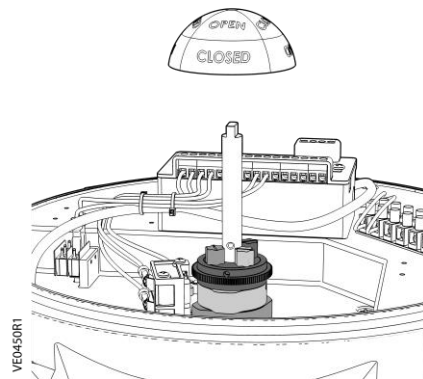

Figure 10: Indicator Rotor Pulled Up from the Indicator Shaft.

2. Manually operate the actuator clockwise until the valve reaches the desired **Closed** position.
3. Loosen the cam locking screw shown below.



NOTE:

The cam locking screw must be loosened before cam adjustments are made and retightened after cam adjustments are complete.

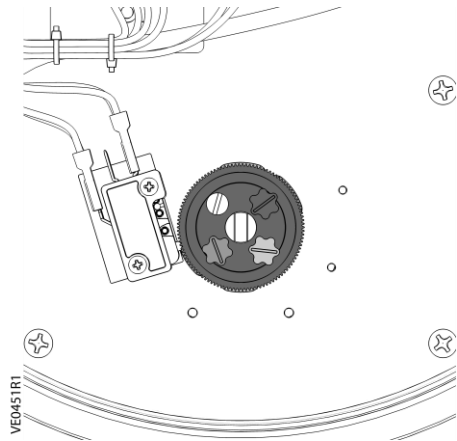

Figure 11: Top View of the Indicator Shaft.



NOTE:

It is possible that the rotation of one cam will move the other cam. If this occurs, hold the other cams or knobs during adjustment.

4. Rotate the red cam adjustment knob by hand or with a flat-blade screwdriver until the red cam lobe activates (presses) the **Closed** switch from a clockwise direction.



NOTE:

If fixed auxiliary switches are installed, the auxiliary cam will activate before the main cam activates.

5. Tighten the cam locking screw.
6. Manually operate the actuator counterclockwise until the valve reaches the desired **Open** position.
7. Loosen the cam locking screw.
8. Rotate the green cam adjustment knob until the green cam lobe activates (presses) the **Open** switch from a counterclockwise direction.
9. Tighten the cam locking screw.
10. Place the indicator rotor back on the indicator shaft.

Setting Mechanical Travel Stops



NOTICE

If the unit came assembled to a valve, the stops have been factory-set and **DO NOT** need adjustment.

Mechanical travel stops are designed to prevent overtravel while manually operating the actuator. They are not designed to stop the electric motor.

Mechanical travel stops are located outside of the actuator base for easy readjustment. Stainless steel lock nuts with O-ring seals hold the travel stops securely

in place. Travel stop spacers are used to ensure that travel stop bolts are not engaged to where they could limit 0° to 90° electrical operation.



NOTE:

Actuator Sizes Axxx.13K and Axxx.18K do not use travel stop spacers.

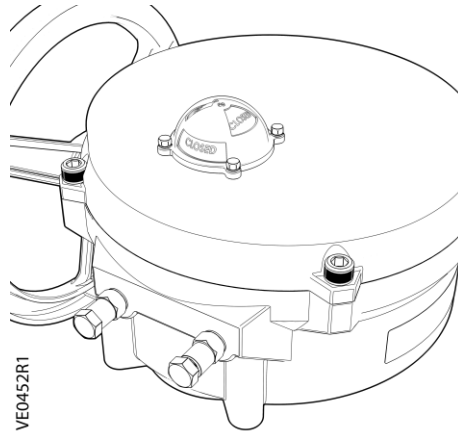

Figure 12: Mechanical Travel Stops (CW Close)

Complete the following steps to set the mechanical travel stops:

1. Manually drive the actuator to the **Closed** position.
2. Once the actuator is in the **Closed** position, rotate the handwheel clockwise:
 - 1/2 turn for Actuator Size Axxx.600.
 - 1 turn for Actuator Sizes Axxx.1K and Axxx.2K.
 - 1/2 turn for Actuator Sizes Axxx.3K, Axxx.5K, and Axxx.6K.
 - 2 turns for Actuator Sizes Axxx.13K and Axxx.18K.
3. Adjust the **Closed** travel stop bolt until the travel stop spacer is fully engaged or the travel stop bolt contacts the output segment gear.
4. Lock the travel stop bolt in position with the locknut.
5. Manually drive the actuator to the **Open** position.
6. Once the actuator is in the **Open** position, rotate the handwheel counterclockwise:
 - 1/2 turn for Actuator Size Axxx.600.
 - 1 turn for Actuator Sizes Axxx.1K and Axxx.2K.
 - 1/2 turn for Actuator Sizes Axxx.3K, Axxx.5K and Axxx.6K.
 - 2 turns for Actuator Sizes Axxx.18K and Axxx.18K.
7. Adjust the **Open** travel stop bolt until the travel stop spacer is fully engaged or the travel stop bolt contacts the output segment gear.
8. Lock the travel stop bolt in position with the locknut.

Field or Factory-Installable Options

Auxiliary Switches

Auxiliary switch kits are a field- or factory-installable option for all A-Series actuators. Switch kits are comprised of dry-contact (voltage-free) SPDT mechanical switches that are used to indicate travel position. Switches are arranged into two stacks.

- For Actuator Size Axxx.600 to Axxx.6K, Stack 2 activates 3° before switches in Stack 1.
- For Actuator Size Axxx.13K and Axxx.18K, the switch that activates 3° early depends on the direction of travel.

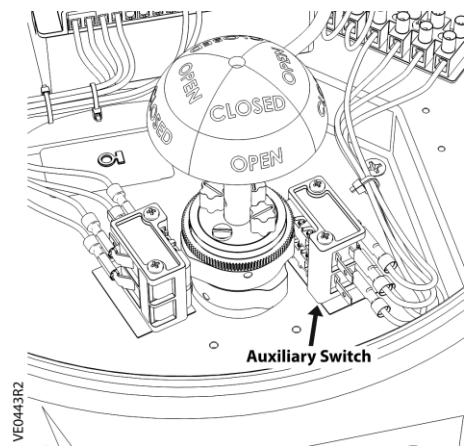

Figure 13: Fixed Auxiliary Switches Installed in an A-Series Industrial Actuator.

Two end switches are standard on all A-Series electric actuators. These are a single set of switches that activate 3° before the travel limit switches. Adjustable auxiliary (Mid-Travel) switches can be fit as single, independent switches or in sets. If fitted as a set, one of the switches in the set will activate 3° before the other. Each switch set is activated independently from other switch sets. For additional switches contact your local Siemens office or Customer Service.

The maximum number and configuration of switches depends on the actuator size and application of the A-Series actuator. Terminal block availability due to installation of other options may also limit the maximum number of switches.

Torque Switches (13K and 18K Only)

Mechanical torque switches are factory-installed on all Model 13K and 18K A-Series electric actuators.

Installation is simple, but due to the requirement for special calibration equipment, it is not available for field installation. Modifying the factory torque setting voids the actuator warranty. Removal of the switch plate invalidates factory calibration.



NOTICE

- Torque switches are not field-adjustable. Adjustment of torque switches in the field will void warranty.
- Removal of the switch plate with torque switches in the field will void warranty.

The worm is pinned to the worm shaft, which is held in position with a stack of disc springs at both ends. The torque transmitted through the worm to the output worm gear acts directly against the disc springs, which compress proportionately. The worm and worm shaft shift axially as a result.

A specially-designed drive lever and pin is incorporated into a groove on the worm, providing the profile for the torque switching mechanism.

- A drive lever and pin ride in the worm gear torque sensor groove, and in turn drives a cam. The cam then actuates its electrical switch, which interrupts the power to the motor winding when the torque exceeds the setting.
- The motor can still be powered to run in the opposite direction. When powered in the opposite direction, the tripped torque switch will automatically release.

External Signal Feedback Potentiometer

Potentiometers are a field- or factory-installable option for continuous duty actuators. Actuators that are not continuous duty do not have a pot gear fitted on their indicator shafts and must be fitted with a new indicator shaft in the factory. A-series electric actuators fitted with electronics for modulating applications already fit a potentiometer and cannot fit a second. In this case, retransmission of position is provided through the modulating electronics package.

Feedback Potentiometer Kit

Kit contents:

- Potentiometer Assembly
- No. 6 Cross Drive Pan Head Screws (qty 2)
- No. 6 Internal Lockwashers (qty 2)
- 4-pole Terminal Strip
- Terminal Strip Marker
- Wiring Diagram

Required Tools

- Screwdriver, 3/16" (5 mm), flat-blade
- Screwdriver, No. 2 Phillips

Installation Instructions

1. Orient the actuator in the full open (counterclockwise) position.
2. Install the potentiometer next to the indicator shaft where two threaded holes are provided for installation.
3. Align the raised green rib on pot gear with the center line of the indicator shaft.
4. Push the assembly towards the cam to mesh the gears, then tighten the mounting screws.
5. Rotate the actuator handwheel so that the red cam lobe is facing the body of the potentiometer. Ensure that the cam is not touching the potentiometer assembly. Readjust the assembly position if necessary.
6. Cut the terminal marker to fit the 4-pole terminal strip.

Field or Factory-Installable Options

External Signal Feedback Potentiometer

7. Mount the 4-pole terminal strip and marker on the switch plate.
8. Wire the potentiometer to the terminal strip following the new wiring diagram .
9. Affix the new wiring diagram sticker to the inside of the cover.



The Factory will require the wiring diagram drawing number and model of the existing unit for a retrofit with a potentiometer. A new wiring diagram will be provided based upon this information.

Basic Tools

Common to All Units	
Terminal connections, cam adjustment	Screwdriver, 1/4" (6 mm) flat-blade
All switches, terminal strip, torque switch plate	Screwdriver, No. 1 Phillips
Switch plate screws, capacitor	Screwdriver, No. 2 Phillips

Actuator Size Axxx.600		
Mounting nuts	Wrench, 1/2"	Wrench, M8
Cover captivated capscrews	Hex key, 1/4"	Hex key, M8
Travel stop adjusting bolts and jam nuts	Wrench, 7/16"	Wrench, M6
Motor mount socket flat-blade capscrew	Hex key, 3/32"	
Motor mount socket head capscrew	Hex key 9/64"	
Conduit entry plug (1/2" NPT)	Hex key 3/8"	Hex key M20

Actuator Sizes Axxx.1K and Axxx.2K		
Mounting nuts (small pattern)	Wrench, 1/2"	Wrench, M8
Mounting nuts (large pattern)	Wrench, 3/4"	Wrench, M12
Cover captivated capscrews	Hex key, 5/16"	Hex key, M10
Travel stop adjusting bolts and jam nuts	Wrench, 9/16"	Wrench, M10
Motor mount socket head capscrews	Hex key, 5/32"	
Conduit entry plug (3/4" NPT)	Hex key, 9/16"	Hex key, M25

Actuator Sizes Axxx.3K, Axxx.5K, and Axxx6K		
Mounting nuts (small pattern)	Wrench, 3/4"	Wrench, M12
Mounting nuts (large pattern)	Wrench, 1-1/8"	Wrench, M20
Cover captivated capscrews	Hex key, 3/8"	Hex key, M20
Travel stop adjusting bolts and jam nuts	Wrench, 3/4"	Wrench, M12
Motor mount socket head shoulder bolt	Hex key, 5/32"	Hex key, M12
Motor mount socket head capscrews	Hex key, 3/16"	
Conduit entry plug (3/4" NPT)	Hex key, 9/16"	Hex key, M25

Actuator Sizes Axxx.13K and Axxx.18K		
Mounting nuts (small pattern)	Wrench, 3/4"	Wrench, M12
Mounting nuts (large pattern)	Wrench, 1-1/8"	Wrench, M20
Cover captivated capscrews	Hex key, 3/8"	Hex key, M12
Travel stop adjusting bolts	Wrench, 5/16"	Wrench, M25
Motor mount socket head shoulder bolt	Hex key, 5/32"	
Motor mount socket head capscrews	Hex key, 3/16"	
Conduit entry plug (3/4" NPT)	Hex key, 9/16"	Hex key, M25

Troubleshooting

Problem	Possible Cause	Solutions
Actuator does not operate	Override is engaged	Push handwheel in all the way.
	Wiring is incorrect	Check wiring and power supply.
	Actuator motor has reached its thermal shutdown temperature	Allow time to cool.
Actuator operates in reverse direction	Field wiring is reversed	Rewire field wiring
Actuator does not fully close valve (or open valve)	Limit switches are pressed in	Readjust travel limit switches
	Mechanical travel stop is stopping actuator	Adjust mechanical travel stops.
	Valve torque requirement is higher than actuator output	Manually override out of seat, try angle seating or larger actuator.
	Optional torque switches are activating	Valve torque exceeds actuator torque rating – consult factory.
	Voltage power supply is low	Check power source.
Engaging override handwheel does not shut off motor	Override pin is corroded or damaged	Clean and check for smooth operation of the override switch pin.
	Override switch is damaged	Replace switch.
Disengaging override handwheel does not restart motor	Not completely disengaged	Push handwheel in as far as possible (no yellow showing)
	Override pin is damaged and/or does not activate switch	Replace override pin.
	Incorrect wiring of override switch	Check wiring.
Motor runs but worm and gear segment do not	Worm gear segment is not meshing with worm	Remove switch plate and inspect, adjust travel stops to prevent gear disengaging.
	Pin/Key on Worm/Motor drive gear sheared	Replace Pin/Key on drive gear.
Corrosion Inside unit	Condensation forming	Test heater wiring, should have constant power.
	Water leaking in	Check all seals and possible water entry through conduit.

A-Series 24V On/Off Electric Actuator

Safety

This device left the factory in proper condition to be safely installed and operated in a hazard-free manner. The notes and warnings in this document must be observed by the user to ensure hazard-free operation of this device.

All necessary precautions must be taken to prevent damage due to rough handling, impact, or improper storage. Do not use abrasive compounds to clean the device or scrape its surfaces with any objects.

Configuration and setup procedures for this device are described in this manual. Proper configuration and setup are required for the safe operation of this device.

The control system in which this device is installed must have proper safeguards to prevent injury to personnel, or damage to equipment, should a failure of system components occur.



⚠ WARNING

Installation, commissioning, operation and maintenance of the unit must be performed under strict observation of all applicable codes, standards, and safety regulations.

The actuator must only be installed, commissioned, operated and repaired by qualified personnel. A qualified person is one who is trained in:

- The operation and maintenance of electrical equipment and systems in accordance with established safety practices.
- Procedures to energize, de-energize, ground, tag and lockout electrical circuits and equipment in accordance with established safety practices.
- The proper use and care of personal protective equipment (PPE) in accordance with established safety practices.
- First aid.

This document does not cover every detail about every version of the product described. It does not cover every potential occurrence concerning the installation, operation, maintenance and use of this device.

If situations transpire that are not documented in sufficient detail, please request the required information from the Siemens Distributor or Representative responsible for your area.

Heater

All A-Series electric actuators include a heater to prevent condensation from forming inside the actuator. This PTC (Positive Temperature Coefficient) style heater has a unique temperature-resistance characteristic. The heater self-regulates by increasing its electrical resistance relative to its temperature. The heater does not require external thermostats or switches to control its heat output.

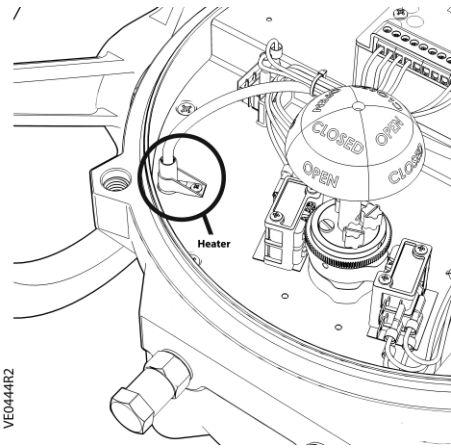

Figure 14: Heater Installed on an A-Series Actuator Switch Plate.



NOTE:

The heater must have constant power supply to be effective.



WARNING

The heater surface can reach temperatures in excess of 392°F (200°C).

Actuation

Manual Operation

The manual override operates like a watch adjusting knob. To engage the manual override, simply pull the handwheel to its outermost position. A yellow stripe is revealed to visually indicate manual override engagement as shown below. The two handwheel positions, engaged and disengaged, are held in place with the use of spring plungers. The handwheel remains in position until physically moved.

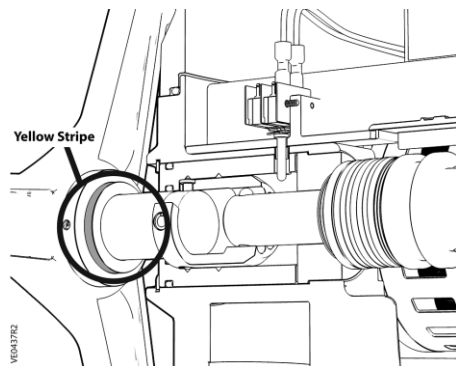

Figure 15: Engaged Handwheel Showing Yellow Stripe.

Once the manual override is engaged, rotate the handwheel in the clockwise direction to rotate the output shaft in the clockwise (close) direction and vice-versa.

To disengage the manual override, push the handwheel towards the actuator until the yellow stripe is hidden.



⚠ CAUTION

A label on the handwheel hub warns users not to exceed a specific “rim pull” force, for each size of actuator.

If the “rim pull” force is exceeded, the roll pin securing the handwheel onto the manual override shaft is designed to shear, which prevents serious internal gearing damage.

Remote Operation

To control the actuator remotely from a process controller, you must apply 24 Vac or 24 Vdc to the actuator. This control signal voltage can be applied locally or remotely from a process controller.



⚠ CAUTION

- Verify that the main electric power supplied to the actuator is in compliance with the specifications on the actuator label.
- Engaging the handwheel before or during the application of a control signal voltage will prevent the actuator motor from operating.
- If torque switches are installed in the actuator, an over-torque condition will prevent the actuator motor from operating.

Commissioning

Wiring the Actuator



⚠ WARNING

Turn off all power and lockout/tag out service panel before installing or modifying any electrical wiring.

1. Remove the actuator cover and place it in a safe location.
2. Wire the actuator according to the wiring diagram attached to the inside of the actuator cover.

	<p>NOTICE</p> <ul style="list-style-type: none"> • Each actuator is provided with two conduit entries. Use one for power and the other for control wiring. • A minimum of 18 AWG wire is recommended for all field wiring. • The terminals on the actuator switch plate, On/Off Controller or Servo NXT accept wire sizes ranging from 14 to 22 AWG. • The conduit connections must be properly sealed to maintain the weatherproof integrity of the actuator enclosure.
---	---

	<p>CAUTION</p> <p>When wiring an A-Series Industrial Electric Actuator for two-position (On/Off) control: If the power to an actuator is commanded to be off, you must ensure that there is no extraneous or leakage voltage between hot and common. Leakage voltage greater than 3 Vac can cause actuator failure.</p> <p>The controller should use at minimum, a one-second time delay for command signal reversal. Instantaneous command reversals may cause actuator failure.</p>
---	--

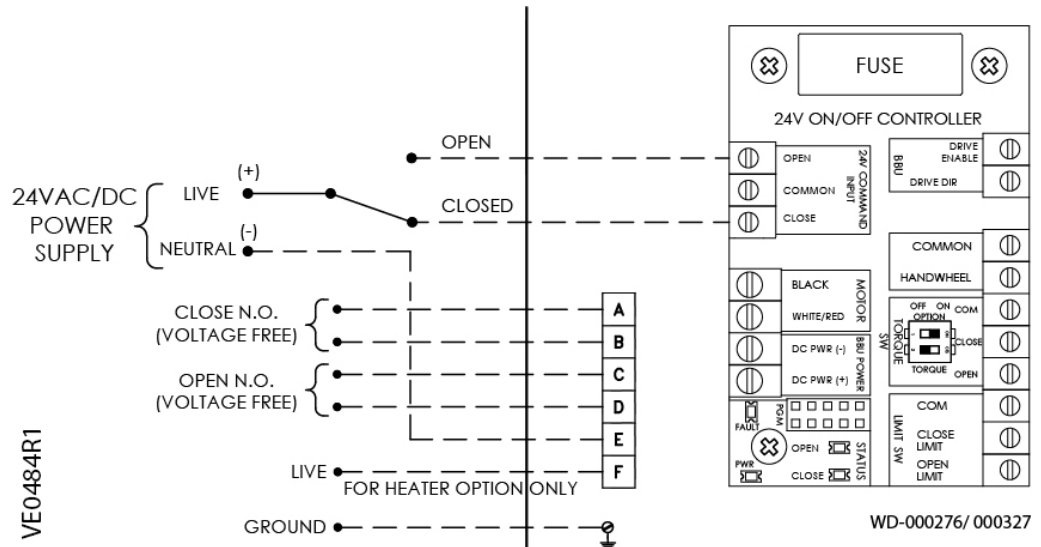

Figure 16: Sample Field Wiring Diagram for A-Series 24V On/Off Actuator with Auxiliary Switches.

Setting Travel Limit Switch Cams

A-Series actuators use a cam design along with two SPDT mechanical switches to set the **Open** and **Closed** positions of the valve.

The green cam actuates the 'open' switch when the actuator reaches the **Open** position. Similarly, the red cam actuates the 'closed' switch when the actuator reaches the **Closed** position.

Standard factory setting of the travel limit switches allows 90° travel between the **Open** and **Closed** positions. Cams for each switch are adjustable for applications where less than 90° travel is desired between the **Open** and **Closed** positions.

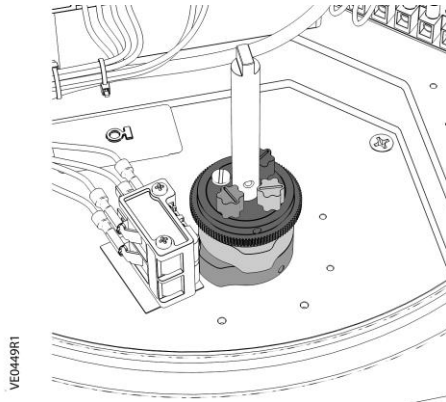

Figure 17: Two SPDT Travel Limit Switches.

Complete the following steps to adjust the travel limit cams:

1. Remove the indicator rotor by pulling it away from the indicator shaft as shown below.

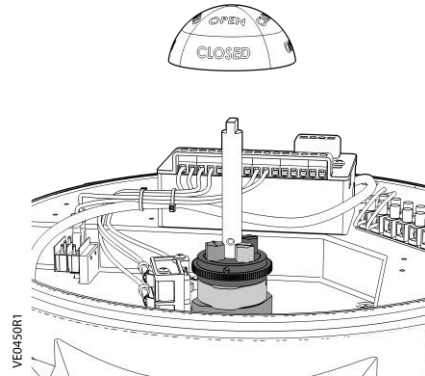

Figure 18: Indicator Rotor Pulled Up from the indicator Shaft.

2. Manually operate the actuator clockwise until the valve reaches the desired **Closed** position.
3. Loosen the cam locking screw shown below.

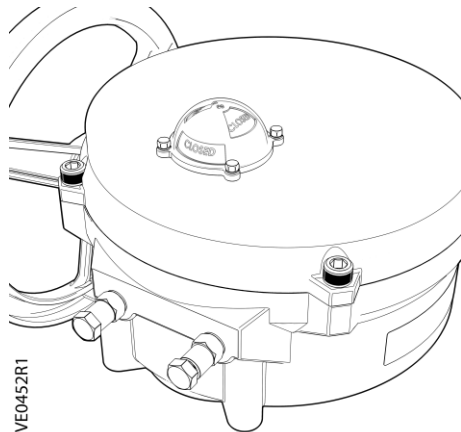

Figure 19: Top of the Indicator Cam Shaft.

**NOTE:**

It is possible that the rotation of one cam will move the other cam. If this occurs, hold the other cams or knobs during adjustment.

4. Rotate the red cam adjustment knob by hand or with a flat-blade screwdriver until the red cam lobe activates (presses) the **Closed** switch from a clockwise direction.
5. Manually operate the actuator counterclockwise until the valve reaches the desired **Open** position.
6. Rotate the green cam adjustment knob until the green cam lobe activates (presses) the **Open** switch from a counterclockwise direction.
7. After both travel switch adjustments have been completed, tighten the cam locking screw and place the indicator rotor back on the indicator shaft.

Setting Mechanical Travel Stops

Mechanical travel stops are designed to prevent overtravel while manually operating the actuator. They are not designed to stop the electric motor.

Mechanical travel stops are located outside of the actuator base for easy readjustment. Stainless steel lock nuts with O-ring seals hold the travel stops securely in place as shown below.

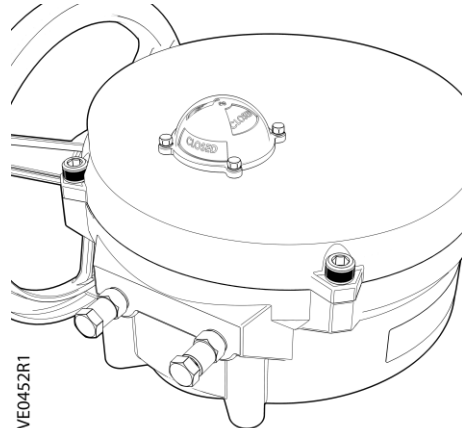

Figure 20: Mechanical Travel Stops (CW Closed).

Complete the following steps to set the mechanical travel stops:

1. Manually drive the actuator to the **Closed** position.
2. Once the actuator is in the **Closed** position, rotate the handwheel clockwise:
 - 1/2 turn for Housing Size Axxx.600.
 - 1 turn for Housing Size Axxx.1K.
 - 1/2 turn for Housing Size Axxx.3K.
3. Adjust the **Closed** travel stop bolt until it contacts the output segment gear and lock it in position with the locknut.
4. Manually drive the actuator to the **Open** position.
5. Once the actuator is in the **Open** position, rotate the handwheel counterclockwise:
 - 1/2 turn for Housing Size Axxx.600.

- 1 turn for Housing Size Axxx.1K.
 - 1/2 turn for Housing Size Axxx.3K.
6. Adjust the **Open** travel stop bolt until it contacts the output segment gear and lock it in position with the locknut.

Configuring Your 24V On/Off Controller

Every A-Series 24V On/Off Actuator is fitted with a 24V On/Off Controller as shown below.

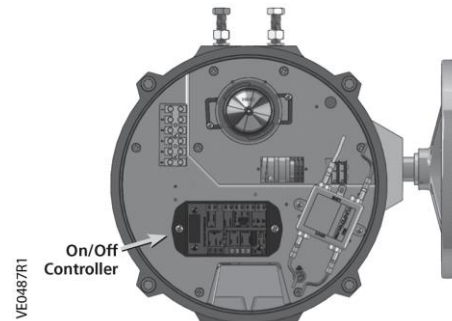

Figure 21: A-Series 24V On/Off Actuator.

The 24V On/Off Controller offers 3-wire control for the actuator.

- To drive the actuator in the open direction, 24 Vdc or 24 Vac power must be applied between the **OPEN** and **Common** terminals of the controller.
- Similarly, to drive the actuator in the close direction, 24 Vdc or 24 Vac power must be applied to the **CLOSE** and **Common** terminals of the controller.

When the command signal is first applied, the Controller will wait for 1 second before powering the actuator motor. This delay is necessary to prevent a simultaneous reversal of the motor if an abrupt change in command signal direction occurs (instant reverse delay).

Once the actuator has reached the **OPEN** or **CLOSE** position, the travel limit switch is activated and the controller turns off power to the motor.



NOTE:

Verify that the main electric power supplied to the actuator is in compliance with the specifications on the product label.

DIP Switch Setting

The DIP switches on the 24V On/Off Controller are dependent on the installation of mechanical torque switches in the actuator. The table below shows the DIP switch settings for the 24V On/Off Controller.

Table 1: DIP switch settings for the 24V On/Off Controller.

Mechanical Torque Switches Installed	DIP Switch 1	DIP Switch 2
YES	OFF	OFF
NO	OFF	OFF

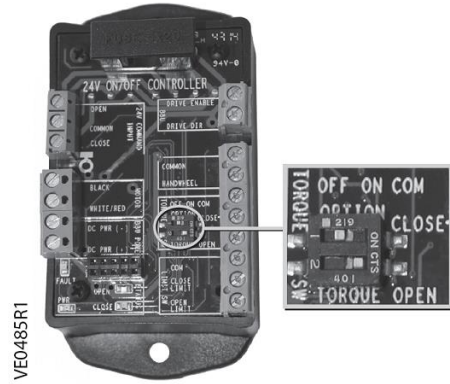

Figure 22: DIP Switch Settings when Mechanical Torque Switches are Installed in an Actuator.



NOTE:

An engaged torque switch will prevent the actuator motor from operating in the over-torque direction.

The 24V On/Off Controller fan has four LEDs for status and fault indication as shown below.

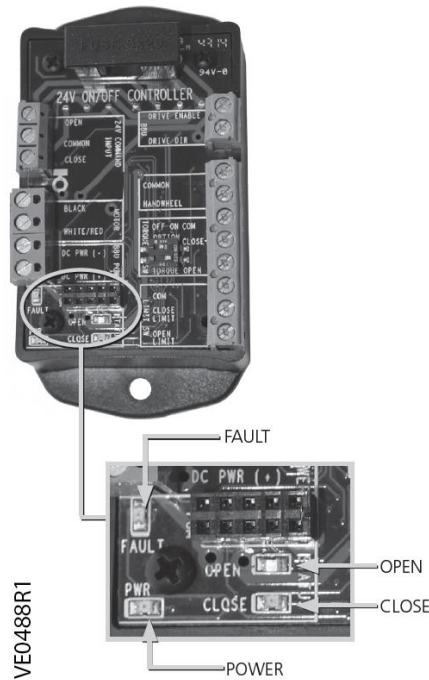

Figure 23: 24V On/Off Controller LEDs.

The LED codes for the 24V On/Off Controller are described in the following table.

Table 2: LED codes for the 24V On/Off Controller.

LED Behavior	Meaning
Pwr LED flashes green ever 1/2 second.	The actuator has power and is operational.
Fault LED glows red.	The hand-wheel is engaged/pulled out.
	The Open or Close torque switch is engaged.

LED Behavior	Meaning
	Both of the travel limit switches are engaged at the same time.
Open LED glows green	The actuator is being driven in the open direction.
Close LED glows red	The actuator is being driven in the close direction.

Field or Factory-Installable Options

Auxiliary Switches

Auxiliary switches are a pair of dry-contact (voltage-free) SPDT mechanical switches used to indicate travel position to remote customer control systems.

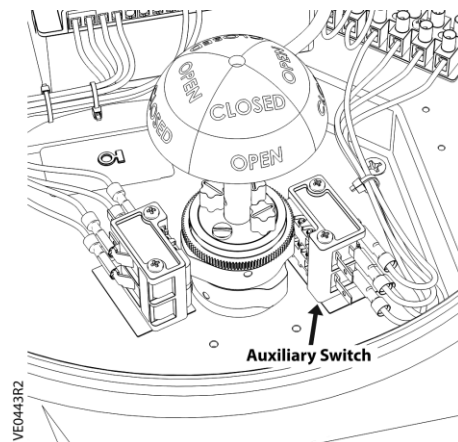

Figure 24: Fixed Auxiliary Switches Installed in an A-Series Industrial Actuator.



NOTES:

1. Fixed Auxiliary switches activate 3° before the travel limit switches. They are available as a factory- and field-installable option.
2. Adjustable auxiliary switches can be set to any position. They are available as a factory- or field installable option.

Basic Tools

Common to All Units	
Terminal connections, cam adjustment	Screwdriver, 1/4" tip flat tip blade
All switches, terminal strip, torque switch plate	Screwdriver, No. 1 Phillips
Switchplate screws	Screwdriver, No. 2 Phillips
Housing Size Axxx.600	
Mounting nuts	Wrench, 1/2"
Cover captivated capscrews	Hex key, 1/4"
Travel stop adjusting bolts	Wrench, 7/16"
Travel stop jam nuts	Wrench, 7/16"

Common to All Units	
Conduit Entry Plug (1/2" NPT)	Hex key, 3/8"
Housing Size Axxx.1K	
Mounting nuts (small pattern)	Wrench, 1/2"
Mounting nuts (large pattern)	Wrench, 3/4"
Cover captivated capscrews	Hex key, 5/16"
Travel stop adjusting bolts	Wrench, 3/16"
Travel stop jam nuts	Wrench, 9/16"
Conduit Entry Plug (3/4" NPT)	Hex key, 9/16"
Housing Size Axxx.3K	
Mounting nuts (small pattern)	Wrench, 3/4"
Mounting nuts (large pattern)	Wrench, 1-1/2"
Cover captivated capscrews	Hex key, 3/8"
Travel stop adjusting bolts	Wrench, 3/4"
Travel stop jam nuts	Wrench, 3/4"
Conduit Entry Plug (3/4" NPT)	Hex key, 5/16"

Troubleshooting

Troubleshooting Guide

The A-Series 24V On/Off actuator is easy to configure and operate, but if problems do occur, the following guide can assist in troubleshooting:

1. Observe the **Pwr** LED on the 24V On/Off Controller to verify that proper electrical power has been connected.
 - ⇒ If the **Pwr** LED is flashing green, the actuator has been powered correctly.
2. Observe the **Fault** LED.
 - If the **Fault** LED on the 24V On/Off Controller is turned on red, see the table in DIP Switch Setting [→ 29] to determine the root cause of the fault. After the root cause of the fault has been addressed, the **Fault** LED should turn off.
3. If the problem still persists see the Actuator Troubleshooting Chart [→ 32].

Actuator Troubleshooting Chart

Problem	Possible Cause	Solutions
Actuator motor does not run in either direction and the Pwr LED on the 24V On/Off Controller is flashing green.	Manual override/handwheel is engaged	Push handwheel in all the way.
	Wiring is incorrect	Check wiring and power supply
Actuator operates in reverse directions	Field wiring is reversed	Rewire field wiring per wiring diagram.
Actuator does not fully close valve	Limit switches are set incorrectly	Readjust travel limit switches.

Problem	Possible Cause	Solutions
(or open valve).	Mechanical travel stops are set incorrectly	Adjust mechanical travel stops.
	Valve torque requirement is higher than actuator output	Manually override out of seat, try angle seating or larger actuator.
	Optional torque switches are activating	Valve torque exceeds actuator torque rating – consult factory.
	Voltage power supply is low	Check power source.
Corrosion inside unit	Water leaking in	Check all seals and possible water entry through conduit.
Actuation only runs in one direction	Wiring is incorrect	Correct field wiring.
	Control signal is incorrect	Check/correct the control signal wire

Troubleshooting Example

The following example demonstrates a typical troubleshooting process.

Assume these starting conditions:

1. The handwheel is engaged (pulled away from the actuator).
2. The 24V On/Off Controller has been configured to enable torque switches, but torque switches are not physically installed on the actuator.
3. The 24 Vac signal has been properly applied between the **Open** and **Close** terminals of the 24V On/Off Controller. The **Pwr** LED is flashing indicating that the control signal has been properly applied.

The **Fault** LED on the 24V On/Off Controller is turned on red. Evaluate all possible reasons for the **Fault** LED to be turned on as shown in the table in DIP Switch Setting [→ 29].

1. Observe if the handwheel is engaged.
 - In this case, the handwheel is engaged. Disengage the handwheel by pushing it in to eliminate a possible reason for the **Fault** LED to be turned on red.
2. Evaluate if the limit switches have been correctly wired.
3. Check if the 24V On/Off Controller has been configured correctly to enable or disable the torque switches.

In this case, torque switches have not been installed in the actuator but the 24V On/Off Controller has been configured to enable the torque switches. Correctly configure the 24V On/Off controller correctly to disable the torque switches as shown table in DIP Switch Setting [→ 29].

⇒ The **Fault** LED on the 24V On/Off Controller turns off and the actuator is now ready for service.

A-Series Servo NXT Modulating Controller

Safety



⚠ WARNING

Equipment controlled by this device can generate large mechanical forces during normal operation.

This device left the factory in proper condition to be safely installed and operated in a hazard-free manner. The notes and warnings in this document must be observed by the user to ensure hazard-free operation of this device.

All necessary precautions must be taken to prevent damage due to rough handling, impact, or improper storage. Do not use abrasive compounds to clean the device or scrape its surfaces with any objects.

Configuration and setup procedures for this device are described in this manual. Proper configuration and setup are required for the safe operation of this device.

The control system in which this device is installed must have proper safeguards to prevent injury to personnel, or damage to equipment, should a failure of system components occur.



⚠ WARNING

Installation, commissioning, operation and maintenance of the unit must be performed under strict observation of all applicable codes, standards, and safety regulations.

The actuator must only be installed, commissioned, operated and repaired by qualified personnel. A qualified person is one who is trained in:

- The operation and maintenance of electrical equipment and systems in accordance with established safety practices.
- Procedures to energize, de-energize, ground, tag and lockout electrical circuits and equipment in accordance with established safety practices.
- The proper use and care of personal protective equipment (PPE) in accordance with established safety practices.
- First aid.

This document does not cover every detail about every version of the product described. It does not cover every potential occurrence concerning the installation, operation, maintenance and use of this device.

If situations transpire that are not documented in sufficient detail, please request the required information from the Siemens Distributor or Representative responsible for your area.

Description of Operation

The A-Series Servo NXT provides complete modulating control and monitoring of the Siemens A-Series Electric Actuator. The basic function of the Servo NXT is to position the A-Series Actuator in response to a command signal from a process controller. The

process controller contains a desired process setpoint entered by the user, and continually monitors the process variable (such as flow rate, tank level, and so on) through some type of sensor. Varying the command signal to the Servo NXT will cause the actuator to change position, which will move the associated control valve to modify the process variable. The process controller continually calculates and transmits the appropriate command signal to the Servo NXT to maintain the process at the desired setpoint.

The command signal to the Servo NXT can be various DC voltage ranges (0 to 5V, 0 to 10V, 2 to 10V) or a 4 to 20mA current source. The Servo NXT simultaneously provides a feedback output signal, representing the current actuator position. The retransmission output signal reported by the Servo NXT can also be various DC voltage ranges (0 to 5V, 0 to 10V) or a 4 to 20 mA current source. These settings along with specific operating modes are enabled by a simple-to-use configuration menu.

User Interface

The Servo NXT features a rich, LED-based menu that displays both configurable settings and operational status. Indicators are grouped together based on function, shown by their respective label(s). Without any user interaction, the Servo NXT will display the factory default product settings, in addition to mode of operation, valve position, and fault status.

Product Settings

The product settings determine how the Servo NXT will respond to commands from the process controller. These must be defined and verified before operation begins. The settings that can be adjusted on the Servo NXT are, in clockwise order:

- **Input** – Input Command
- **Output** – Output Command
- **Fail** – Failure Position
- **Close Speed** – Close Speed Control
- **Open Speed** – Open Speed Control
- **Dead Band** – Dead Band Control
- **Torque Switch** – Torque Switch Detection
- **Reverse Acting** – Reverse Acting Mode

All units ship with default settings from the factory.

Feature	Setting
Input Command	4 to 20 mA
Output Command	4 to 20 mA
Failure Position	Last
Open Speed Control	100%
Close Speed Control	100%
Dead Band Control	3%
Torque Switch Detection	Off
Reverse Acting Mode	Off

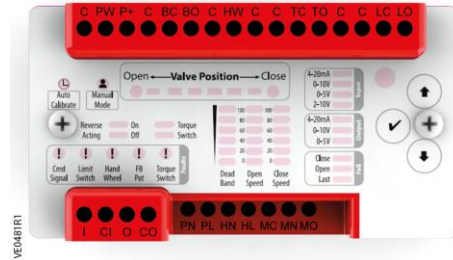

Figure 25: Servo NXT Menu.

Changing Settings

Keypad on the Servo NXT

The keypad is located on the right side of the unit, and the keys are labelled based on the operation performed.

- Up arrow - Cycles the cursor (see below) in a counterclockwise direction
- Down arrow - Cycles the cursor in a clockwise direction
- Check mark - Activates the selected setting (if applicable) and saves the current configuration

Settings are changed using the cursor, visualized by a flashing indicator. To produce the cursor, the Up or Down arrow key must be pressed, causing one of the setting indicators to flash. Pressing or holding the Up or Down Arrow will move the cursor in the respective direction, as illustrated below. Producing the cursor does not alter any settings without further user input, and the cursor will automatically timeout if the keypad is not used.

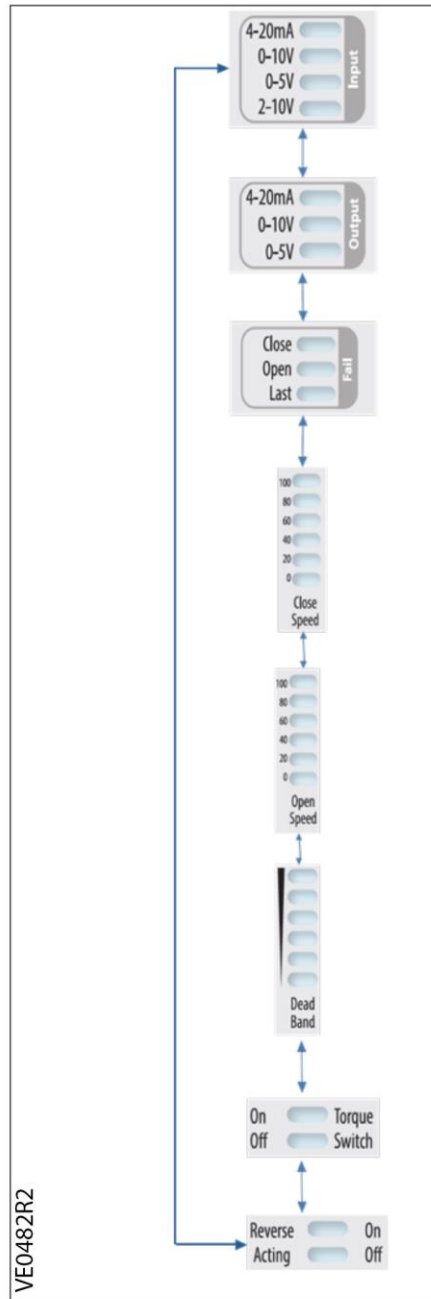

Figure 26: Servo NXT Input Settings.

Once the cursor has been positioned over a desired setting, pressing and holding the check mark for one second or more will activate the selected setting. Attempting to activate a setting that is already active will have no additional effect.

Description of Settings

Input Signal Type

Input signals position the valve under control, based on the magnitude of the signal. During normal operation, the minimum value corresponds to the close position and the

maximum value to the open position. Reverse Acting Mode inverts this relationship (maximum value = close position, minimum value = open position). Only one input signal can be active at a time.

Input Setting	Description
4 to 20 mA (default)	Analog Current Range
	Minimum: 4 mA
	Maximum: 20 mA
0 to 10V	Analog Voltage Range
	Minimum: 0V
	Maximum: 10V
0 to 5V	Analog Voltage Range
	Minimum: 0V
	Maximum: 5V
2 to 10V	Analog Voltage Range
	Minimum: 2V
	Maximum: 10V

Output Signal Type

Output signals report the position of the valve under control, based on the magnitude of the signal. The minimum value corresponds to the close position and the maximum value to the open position. Only one output signal can be active at a time.

Output Setting	Description
4 to 20mA (default)	Analog Current Range
	Minimum: 4mA
	Maximum: 20mA
0 to 10V	Analog Voltage Range
	Minimum: 0V
	Maximum: 10V
0 to 5V	Analog Voltage Range
	Minimum: 0V
	Maximum: 5V

Failure Position

The Failure Position determines how the Servo NXT positions the valve upon loss of input signal. Loss of input signal occurs when the input signal received is outside the valid range of the selected Input Signal Type (for example, an input signal of less than 4 mA for the 4 to 20 mA input). Only one failure position can be active at a time.

Failure position at loss of control signal:

Fail Setting	Description
Close	Valve is closed on loss of input signal
Open	Valve is opened on loss of input signal
Last (default)	Position valve at the last valid commanded position before the loss of input signal

Failure position at loss of power is fail-in-last-position.

Close Speed Control

Close Speed Control determines how quickly the Servo NXT operates the actuator in the close direction. This value is a percentage of the full speed. The illuminated indicators act as a level gauge: activating a speed setting illuminates all lower speed setting indicators. Maximum speed illuminates all indicators, while minimum speed illuminates only one.

Close Speed Setting	Description
0% to 100% (default) Step size: 20%	Actuator close speed as a percentage of full speed

Open Speed Control

Open Speed Control determines how quickly the Servo NXT operates the actuator in the open direction. This value is a percentage of the full speed. The illuminated indicators act as a level gauge: activating a speed setting illuminates all lower speed setting indicators. Maximum speed illuminates all indicators, while minimum speed illuminates only one.

Open Speed Setting	Description
0% to 100% (default) Step size: 20%	Actuator open speed as a percentage of full speed

Dead Band Control

Dead Band Control determines the acceptable offset between the position command provided by the input command and the current position of the actuator, determined from the feedback signal provided by the potentiometer. This value is a percentage of the full input range, and creates an inactive area centered around the desired setpoint. For example, for a 0 to 10V input command, a 2% Dead Band Control setting allows the actuator position to be offset from the desired setpoint by up to 0.1V in either direction, creating a dead band with a span of 0.2V. The illuminated indicators act as a level gauge: activating a dead band setting illuminates all lower dead band setting indicators. Maximum dead band illuminates all indicators, while minimum dead band illuminates only one.

Dead Band Setting	Description
1% to 6% 3% (default) Step size: 1%	Acceptable offset between command position and actuator position

Torque Switch Detection

Torque Switch Detection determines whether the Servo NXT is responding to changes to the torque switch assembly. When on, the Servo NXT will stop the actuator if a torque switch is engaged, signaling that the actuator is operating at torques above its rated torque. This setting should only be activated if torque switches are connected to the Servo NXT.

Torque Switch Detection	Description
On	Actuator movement stopped if the torque switch engages
Off (default)	Torque switch state ignored

Reverse Acting Mode

Reverse Acting Mode determines how the Servo NXT responds to input commands. When on, the Servo NXT will operate inversely to how it operates normally, treating the maximum input signal value as the close command and the minimum input signal as the open command. This setting does not affect the output signal.

Reverse Acting Setting	Description
On	The Servo NXT responds inversely to input commands
Off (default)	The Servo NXT responds normally to input commands

Motor Stall Detection

A standard feature on the Servo NXT is motor stall detection.

- If the feedback signal provided to the Servo NXT by the potentiometer does not match the expected operation, then a fault state is entered.
- More specifically, if the actuator controlled by the Servo NXT is operating the motor either open or close and the feedback potentiometer does not detect any movement, a Motor Stall Fault will occur. This most often occurs when the travel of the actuator is impeded due to excessive valve torque or a blockage in the valve flow stream.
- When a Motor Stall Fault occurs, the actuator will move in the opposite direction of travel from where the fault occurred for 2 seconds. This relieves the actuator and underlying valve from any static torque load.
- After this movement, the actuator will stop and continuously flash all five fault indicators simultaneously. The actuator will not respond to further commands and will remain in this state until the handwheel is engaged.
- After the handwheel is engaged and then disengaged, the actuator will resume normal operation.

In rare cases, it may be desirable to disable this feature. The Motor Stall Detection feature can be disabled by simultaneously pressing and holding the **Up** and **Down Arrow** keys for 5 seconds. After 5 seconds, all valve position indicators will flash simultaneously for 1 second indicating that the feature has been disabled.

The feature can be re-enabled by repeating the process. When the feature is re-enabled, the five fault indicators will flash simultaneously for 1 second.



NOTE:

It is suggested that the Motor Stall Detection be disabled when the Servo NXT is installed in size Axxx.13K and Axxx.18K A-Series actuators due to the slower operating speed.

Operating Modes

Remote Mode

By default, the operating mode of the Servo NXT is remote mode, where the valve is positioned based on input signals. Exiting another mode of operation generally results in the Servo NXT returning to remote mode.

Local Mode

Local Mode is entered if a connection is made to the control box terminals and a command signal is present. This allows the Servo NXT to be controlled by a local control box, mounted to or near the actuator. See the section on the control box for more information.

Manual Mode

This operating mode allows the actuator to be controlled directly from the user interface on the Servo NXT. By utilizing the keypad, the user can change the position of the valve with a single button press.

Manual mode is exited in the same way it is entered: by pressing and holding the manual mode button for 1 second. While in manual mode, the indicator next to the manual mode button remains lit. Manual mode can only be entered during remote operation.

- Up arrow – Energizes the actuator in the open direction. The actuator will operate until it reaches the end of travel or the user presses the **check mark** key.
- Down arrow - Energizes the actuator in the close direction. The actuator will operate until it reaches the end of travel or the user presses the **check mark** key.
- Check mark – Sets the current actuator position as the command position. If the actuator is energized when the button is pressed, it stops in place.

Autocalibration Mode

The Servo NXT uses an automated calibration sequence to determine the operating points for the application in which it is installed. These operating points allow the Servo NXT to calculate the correct feedback position of the product, making autocalibration an important step during commissioning. Servo NXT units that have not been calibrated will flash the indicator next to autocalibration button to show that they are using default values for calculating position.

Autocalibration mode is entered by pressing and holding the Autocalibration button for at least 3 seconds. While in autocalibration mode, the autocalibration indicator remains lit. In addition, the product settings' indicators will change state to show that autocalibration has been entered, and will continue to flash at the end of travel until autocalibration completes. Upon completion of the autocalibration sequence, the

product settings' indicators will return to normal and the autocalibration indicator will remain lit, indicating that the new parameters have been stored.

No other operating modes can be entered during autocalibration, and entering autocalibration mode will override any previous mode of operation.



NOTE:

If the fault indication lights illuminate during autocalibration, then the autocalibration sequence could not be successfully completed. Upon failure of autocalibration, the autocalibration indicator will continue flashing to indicate that default parameters are still being used for positioning. See Troubleshooting Guide [→ 47] for more information.

CAUTION

The Servo NXT will not be remotely controllable during the autocalibration sequence. If autocalibration needs to be aborted, engage (pull out) the handwheel.

Status Indication

Valve Position

This string of indicators provides position information of the valve under control. In addition, if the actuator is operating the valve, then it also indicates the current command position and direction of travel.

- Direction indicators – The Open (green) and Close (red) indicators at both ends of the valve position indicator show the current direction of travel. When the actuator is energized, the corresponding indicator will flash to indicate travel. The green indicator will be lit if the open travel limit is reached. The red indicator will remain lit if the close travel limit is reached.
- Position indicators – The indicators between the direction indicators act as a level gauge, with the fully closed position serving as the zero point. Each indicator represents 15 degrees of travel, so that the total number of illuminated indicators shows the distance the valve is from the fully closed position. As the command signal is changed, a single indicator will flash which represents the relative level of the command signal. The indicators that remain solid represent the relative position of the actuator. Once the actuator reaches the command signal setpoint, the single command signal indicator will stop flashing. This scheme provides the operator with an indication of both the command signal and actuator position using a single display.

Fault Status

The indicators in the lower left of the user interface illuminate in the event of a fault. The occurrence of a fault generally indicates that user intervention is required to restore operation, and these indicators attempt to provide the diagnostic information needed to accomplish this.

The Fault Status indicators are, from left to right:

- Cmd Signal – A valid input command is not present.
- Limit Switch – Both travel limit switches have been engaged, preventing the actuator from operating, or the travel limit switches are not correctly wired to the Servo NXT.
- Handwheel – The actuator handwheel has been engaged (pulled out), or the handwheel switch is not correctly wired to the Servo NXT.
- FB pot – The feedback potentiometer is outside its range of travel or is not correctly wired to the Servo NXT.
- Torque Switch – A torque switch has been engaged, or the torque switches are not correctly wired to the Servo NXT.

In addition, all the fault indicators can be flashing in unison. During autocalibration, this means that the autocalibration sequence has failed. During normal operation, this indicates that a motor stall fault has occurred. See Motor Stall Detection [→ 40] for more detail on a motor stall fault. See Troubleshooting Guide [→ 47] for the actions required to clear a fault.

Status Indicator

The indicators that illuminate the logo in the lower right of the user interface serve as status indicators for the Servo NXT. No matter what operation is performed, these indicators should be flashing on and off. If they are not flashing, see Troubleshooting Guide [→ 47].

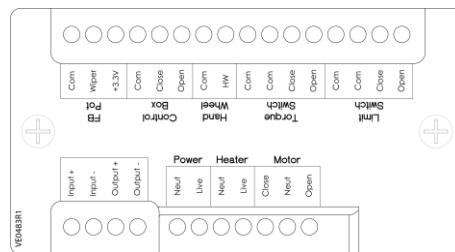

Figure 27: Servo NXT Terminal Labels.

Hardware Description

Terminal Connections



⚠ WARNING

Turn off all power and lockout/tag out service panel before installing or modifying any electrical wiring.

Terminals are provided on the unit to attach stripped wires that connect the Servo NXT to the external sources and signals needed for it to successfully operate. These terminals are positioned on the unit based on physical location of the connecting components and the voltages expected at the connection.

Terminal connections fall into two categories: high/low voltage and customer/actuator connection.

- Connections of differing voltage levels are differentiated by their height on the Servo NXT, with high voltage connections being near the bottom of the unit and low voltage connections being near the top.
- Customer and actuator connections are positioned so that they are easily accessible once the Servo NXT is installed in an actuator.
- Actuator connections are generally made at the factory, and should not require any customer adjustment.
- All connections required for proper operation are bolded in the following table.

	Customer Connection	Actuator Connection
High voltage (>15V)	Power	Heater, Motor
Low voltage (<15V)	Input Signal (Input+, Input-) Output Signal (Output+, Output-)	FB Pot , Control Box, Handwheel , Torque Switch, Limit Switch



NOTE:

See the actuator wiring diagram for wire gauge, torque, voltage, and temperature limits of the terminal blocks. All actuator connections should match the actuator wiring diagram.

Power

Power connection that energizes the Servo NXT and powers the actuator under control. The voltage supplied should be based on the actuator nameplate voltage and the voltage listed on the Servo NXT label.



CAUTION

Verify that the actuator nameplate voltage and the Servo NXT label voltage match before providing power to the unit.

The Servo NXT has an onboard protective fuse that is in line with the input power connection. This protective fuse is rated to 5A, the maximum allowable current draw for the Servo NXT. Therefore, the power supply connected to the input power connection should be rated to provide at least this much current to each Servo NXT.

Heater

The heater is powered by the input power connection. Only Siemens-supplied heaters should be connected to the Servo NXT.

Motor

Connections for the motor that operates the actuator. See the actuator manual for more information on the motor.

Input Signal

Connection for the input signal that positions the valve under control, based on the magnitude of the signal. The signal that is present at this connection should be based on the input setting (see Product Settings [→ 35]).

Input signals are polarized, so miswiring may result in unexpected behavior. Ensure that the wiring diagram is followed when making this connection.

Output Signal

Connection for the output signal that reports the position of the valve under control, based on the magnitude of the signal. The signal that is present at this connection is based on the output setting (see Product Settings [→ 35]).

Output signals are polarized, so miswiring may result in unexpected behavior. Ensure that the wiring diagram is followed when making this connection.



NOTE:

The output signal is powered by the Servo NXT. Never connect an external source to the terminals.

Feedback Potentiometer

Connections for the Feedback Potentiometer are used by the controller to determine the position of the valve.

The Servo NXT provides a logic level voltage across the potentiometer, and then monitors the voltage that is returned on the wiper connection. The wiper voltage will change as the potentiometer is turned, due to the rotation of the cam shaft. During autocalibration, the Servo NXT can save the wiper voltage range and use it to position the actuator accurately and precisely.



NOTES:

1. The Servo NXT has been programmed to monitor a specific range of feedback voltage. Utilizing a potentiometer other than the factory-provided potentiometer may result in unexpected behavior.
 2. Servo NXT feedback potentiometer voltage may be measured between terminals **C** and **PW**. Voltage must be between 0.1 Volts and 3.1 Volts for valve closed and opened positions, respectively. See the S70 Electric Actuator IOM for potentiometer alignment instructions.
-

Handwheel

Connections for the handwheel override switch. When the actuator handwheel is engaged (pulled out), this switch prevents the actuator from operating until the handwheel is disengaged.

The Servo NXT provides a logic level voltage at the HW terminal of this connection. If the handwheel is engaged (pulled out), this pin will get pulled to 0V, signaling the Servo NXT and resulting in a fault.

Torque Switch

Connections for the torque switch assembly, if present, alert the Servo NXT to the presence of excessive torque applied to the actuator.

The Servo NXT provides a logic level voltage at the Open and Close terminals of this connection. If the actuator torque increases above the rated torque, the switch at the applicable connection will pull this pin to 0V, signaling the Servo NXT to enter a fault condition.

Limit Switch

Connections for the travel limit switches indicate to the Servo NXT when an end of travel setpoint has been reached.

The Servo NXT provides a logic level voltage at the Open and Close terminals of this connection. Once one of the travel limit switches is engaged, the switch at the applicable connection will engage and pull this pin to 0V, signaling the Servo NXT to end travel.

For proper operation, both travel limit switches should not be engaged at the same time. This would prevent the Servo NXT from operating the actuator, and results in a fault condition.

**NOTE:**

Low voltage actuator connections are powered by the Servo NXT. An external source should never be connected to these terminals. See the actuator manual for more information on these components, or if these components need to be repaired or replaced.

Quick Start Guide

See the actuator manual before adjusting or replacing any actuator components.

1. Terminate the customer connections at the Servo NXT terminals following the actuator wiring diagram.
 - To reduce noise on the customer cables, power lines and signal lines should not be routed together.
 - Signal lines should be shielded, and the shield line should only be grounded at one end, preferably at the controller.
2. Apply power to the Servo NXT and verify that the Logo is illuminated and flashing on and off.
3. Set the Input Command signal type.
4. If necessary, adjust the other default product settings.
5. Verify (or adjust) the travel limits in the actuator.
 - Actuators are shipped with the travel switches in the factor- default position – close travel limit set at **0** degrees and the open travel limit at **90** degrees.
 - If the travel limit switch settings are moved from the factory-default position, the feedback potentiometer may need to be adjusted for autocalibration to complete.
6. Put the Servo NXT in Autocalibration mode.

- If autocalibration completes, the product is ready for service
 - If autocalibration fails, move to Step 7.
7. Using the Input Command signal, command the actuator to the fully opened position.
 - Observe the Servo NXT as it operates, and correct any faults that occur. See Troubleshooting Guide [→ 47] for more information.
 8. Using the Input Command signal, command the actuator to the fully closed position.
 - Observe the Servo NXT as it operates, and correct any faults that occur.
 9. Return to Step 6.

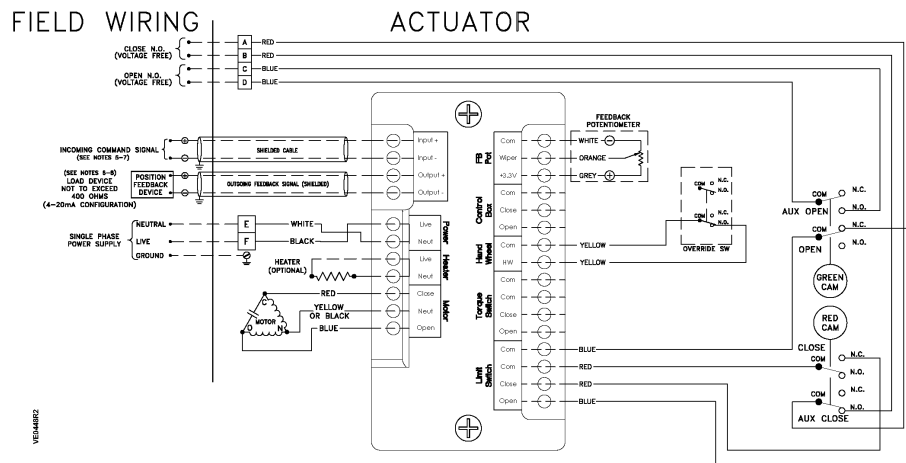

Figure 28: Actuator-Specific Wiring Diagram Located Inside the Actuator Cover.

Troubleshooting Guide

See the actuator manual before adjusting or replacing any actuator components. Before testing or acting on any possible issues, check for any active faults.



⚠ WARNING

Turn off all power and lockout/tag out service panel before installing or modifying any electrical wiring.

Issue	Possible Causes	Possible Solutions
Servo NXT does not turn on when power is applied	Fuse is blown	Verify and replace the fuse.
	Servo NXT is incorrectly wired	Verify wire connections against the wiring diagram.
	Servo NXT is not receiving power	Test the Input Power connection with a multimeter or oscilloscope.
	Power is not correct	Check the provided power against the voltage listed for the Servo NXT and actuator.

Issue	Possible Causes	Possible Solutions
Actuator moves back and forth near setpoint (hunting)	Deadband is too narrow	Increase the deadband setting.
	Excessive noise on the signal lines	Use an oscilloscope to test for the presence of EMI. Utilize EMI reducing techniques to mitigate the issue.
Servo NXT not responding to command signal	Servo NXT in local mode	If local control is being used , ensure the local control station is not active or is set to remote mode. If local control is not being used , test the voltage on the Control Box Open and Close pins relative to the COM pins. Greater than 3V should be measured.
	Servo NXT in manual or autocalibration mode	Check the indicators for manual and autocalibration mode.
	Servo NXT is incorrectly wired	Verify wire connections against the wiring diagram.
Cmd Signal Fault	Command setting	Adjust the Input setting to match the command signal used.
	Servo NXT is incorrectly wired	Verify wire connections against the wiring diagram.
	Servo XT is not receiving the command signal	Test the Input Command connection with a multimeter or oscilloscope.
Limit Switch Fault	Both limit switches are engaged	Adjust the actuator cams.
	Servo NXT is incorrectly wired	Verify wire connections against the wiring diagram.
	Travel limit switch failure	Test the switches to ensure that they are changing states when engaged.
Handwheel Fault	Handwheel is engaged	Disengage (push in) the handwheel.
	Servo NXT is incorrectly wired	Verify wire connections against the wiring diagram.
	Handwheel switch failure	Test the switch to ensure that it is changing states when engaged.
FB Pot Fault	Potentiometer outside of travel range	Operate the actuator to the fully open and fully closed positions, and adjust the potentiometer position as needed.
	Servo NXT is incorrectly wired	Verify wire connections against the wiring diagram.
Torque Switch Fault	Torque Switch setting enabled with no torque switches connected	Disable torque switch setting.
	Torque switch(es) engaged	Check the valve and/or actuator for obstructions.
	Servo NXT is incorrectly wired	Verify wire connections against the wiring diagram.

Issue	Possible Causes	Possible Solutions
	Torque Switch failure	Test the switches to ensure that they are changing states when engaged.
Motor Stall Fault	Operational torque is exceeding the torque rating of the actuator	Check the valve and/or actuator for obstructions. Measure the torque required to rotate the valve and verify against the rated torque.
	Servo NXT is incorrectly wired	Verify wire connections against the wiring diagram.
Fault condition during autocalibration	Fault occurring during calibration	Operate the actuator to the fully open and fully closed positions, and correct any faults that occur.
	Servo NXT is incorrectly wired	Verify wire connections against the wiring diagram.

Issued by
Siemens Industry, Inc.
Smart Infrastructure
1000 Deerfield Pkwy
Buffalo Grove IL 60089
+1 847-215-1000

© Siemens Industry, Inc., 2022
Technical specifications and availability subject to change without
notice.